



EVOLUTIONSERIES

INSTALLATION AND OPERATION MANUAL

GAS BRATT PAN

G580-8

G580-8E

G580-12

G580-12E



Date Purchased _____

Serial Number _____

Dealer _____

Service Provider _____

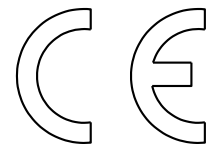

For use in GB & IE

229365-10

MANUFACTURED BY

Moffat Limited

Christchurch
New Zealand

INTERNATIONAL CONTACTS

AUSTRALIA

Moffat Pty Limited

E.Mail: vsales@moffat.com.au
Main Office: (tel): +61 (03) 9518 3888
(fax): +61 (03) 9518 3833
Service: (tel): 1800 622 216
Spares: (tel): 1800 337 963
Customer Service: (tel): 1800 335 315
(fax): 1800 350 281

CANADA

Serve Canada

Web: www.servecanada.com
E.Mail: info@servecanada.com
Sales: (tel): 800 551 8795 (Toll Free)
Service: (tel): 800 263 1455 (Toll Free)

NEW ZEALAND

Moffat Limited

Web: www.moffat.co.nz
E.Mail: sales@moffat.co.nz
Main Office: (tel): 0800 663328

UNITED KINGDOM

Blue Seal

Web: www.blue-seal.co.uk
E.Mail: sales@blue-seal.co.uk
Sales: (tel): +44 121 327 5575
(fax): +44 121 327 9711
Spares: (tel): +44 121 322 6640
(fax): +44 121 327 9201
Service: (tel): +44 121 322 6644
(fax): +44 121 327 6257

UNITED STATES

Moffat

Web: www.moffat.com
Sales: (tel): 800 551 8795 (Toll Free)
(tel): +1 336 661 1556
(fax): +1 336 661 9546
Service: (tel): 800 858 4477 (Toll Free)
(tel): +1 366 661 1556
(fax): +1 336 661 1660

REST OF WORLD

Moffat Limited

Web: www.moffat.co.nz
E.Mail: export@moffat.co.nz

The reproduction or copying of any part of this manual by any means whatsoever is strictly forbidden unless authorized previously in writing by the manufacturer.

In line with policy to continually develop and improve its products, Moffat Ltd. reserves the right to change the specifications and design without prior notice.

© Copyright Moffat Ltd. April 2012.

Blue Seal Gas Bratt Pan

G580-8	BRATT PAN MANUAL TILT	(80 ltr)
G580-8E	BRATT PAN ELECTRIC TILT	(80 ltr)
G580-12	BRATT PAN MANUAL TILT	(120 ltr)
G580-12E	BRATT PAN ELECTRIC TILT	(120 ltr)

Introduction2**Specifications3**

Model Numbers Covered in this Specification

General

Gas Supply Requirements

Electrical Supply Requirements

Water Supply Requirements

Dimensions4**Installation9**

Installation Requirements

Unpacking

Location

Assembly

Gas Connection

Electrical Connection

Water Connection

Commissioning

Operation.....13

Operation Guide

Description of Controls

Lighting Pilot Burner

Lighting Main Burner

Setting the Temperature

Operating the Water Supply Valve

Tilting the Pan - G580-8 / G580-12

Tilting the Pan - G580-8E / G580-12E

Turning off the Bratt Pan (All Models)

Cleaning and Maintenance17

General

After Each Use

Daily Cleaning

Weekly Cleaning

Periodic Maintenance

Fault Finding.....19**Wiring Schematic21****Gas Conversion and Specifications23**

Conversion Procedure

Gas Specifications

Replacement Parts List26

Introduction

We are confident that you will be delighted with your WALDORF GAS BRATT PAN, and it will become a most valued appliance in your commercial kitchen.

To ensure you receive the utmost benefit from your new Waldorf GAS BRATT PAN, there are two important things you can do.

Firstly:

Please read the instruction book carefully and follow directions given. The time taken will be well spent.

Secondly:

If you are unsure of any aspect of the installation, instructions or performance of your appliance, contact your WALDORF dealer promptly. In many cases a phone call could answer your question.

CE Only:

These instructions are only valid if the country code appears on the appliance. If the code does not appear on the appliance, refer to the supplier of this appliance to obtain the technical instructions for adapting the appliance to the conditions for use in that country.



Warning

IMPROPER INSTALLATION, ADJUSTMENT, ALTERATION, SERVICE OR MAINTENANCE CAN CAUSE PROPERTY DAMAGE, INJURY OR DEATH. READ THE INSTALLATION, OPERATING AND MAINTENANCE INSTRUCTIONS THOROUGHLY BEFORE INSTALLING OR SERVICING THIS APPLIANCE.



Warning

INSTRUCTIONS TO BE FOLLOWED IN THE EVENT THE USER SMELLS GAS ARE TO BE POSTED IN A PROMINENT LOCATION. THIS INFORMATION SHALL BE OBTAINED BY CONSULTING THE LOCAL GAS SUPPLIER.



Warning

GREAT CARE MUST BE TAKEN BY THE OPERATOR TO USE THE EQUIPMENT SAFELY TO GUARD IT AGAINST RISK OF FIRE.

- **APPLIANCE MUST NOT BE LEFT ON UNATTENDED.**
- **IT IS RECOMMENDED THAT A REGULAR INSPECTION IS MADE BY A COMPETENT SERVICE PERSON TO ENSURE CORRECT AND SAFE OPERATION OF YOUR APPLIANCE IS MAINTAINED.**
- **DO NOT STORE OR USE GASOLINE OR OTHER FLAMMABLE VAPOURS OR LIQUIDS IN THE VICINITY OF THIS OR ANY OTHER APPLIANCE.**
- **DO NOT SPRAY AEROSOLS IN THE VICINITY OF THIS APPLIANCE WHILE IT IS IN OPERATION.**



Caution

- **This appliance is for professional use and is only to be used by qualified persons.**
- **Only authorised service persons are to carry out installation, servicing or gas conversion operations.**
- **Components having adjustments protected (e.g. paint sealed) by the manufacturer should not be adjusted by user / operator.**
- **DO NOT operate appliance without the legs supplied fitted.**

Model Numbers Covered in this Specification

G580-8 / G580-8E - Gas Bratt Pan, Manual / Electric Tilt - 900mm wide (80ltr).
 G580-12 / G580-12E - Gas Bratt Pan, Manual / Electric Tilt - 1200mm wide (120ltr).

General

G580-8 /G580-8E (80 ltr) Gas Bratt Pan.

A commercial heavy duty, gas fired Bratt Pan fitted with an 80 ltr capacity pan, of full stainless steel pan construction, with a single 6 bar chrome plated steel gas burner and electric piezo ignition giving even heat distribution. This appliance features an electric thermostat burner control and over temperature safety cut-out.

Created for compact modular kitchens, it is fitted with manually (or optional electric power) operated tilting mechanism with a burner cut-out when the pan is tilted.

G580-12 /G580-12E (120 ltr) Gas Bratt Pan.

A commercial heavy duty, gas fired Bratt Pan fitted with an 120 ltr capacity pan, of full stainless steel pan construction, with a single 8 bar chrome plated steel gas burner and electric piezo ignition giving even heat distribution. This appliance features an electric thermostat burner control and an over-temperature safety cut-out.

Created for compact modular kitchens, it is fitted with manually (or optional electric power) operated tilting mechanism fitted with a burner cut-out when the pan is tilted.

Gas Supply Requirements

- Australia / New Zealand Only:

	Natural Gas		LPG (Propane)	
	G580-8 / 8E	G580-12 / 12E	G580-8 / 8E	G580-12 / 12E
Input Rating (N.H.G.C.)	72MJ/hr	90MJ/hr	72MJ/hr	90MJ/hr
Supply Pressure	1.13 - 3.40kPa (4.5" - 13.5" w.g.)		2.75 - 4.50kPa (11" - 18" w.g.)	
Burner Pressure	0.76kPa (*) (3.0" w.c.)	0.60kPa (*) (2.4" w.c.)	2.4kPa (*) (9.5" w.c.)	2.5kPa (*) (10.0" w.c.)
Gas Connection	3/4" BSP Male			

- UK Only:

Appliance Classification

Category: II_{2H3P}.
 Flue Type: A₁.

		Natural Gas (G20)		Propane (G31)	
		G580-8 / 8E	G580-12 / 12E	G580-8 / 8E	G580-12 / 12E
Heat Input (nett)	Nominal	18.5kW	23kW	18.5kW	23kW
Gas Rate (nett)	Nominal	1.96m ³ /hr	2.43m ³ /hr	1.44kg/hr	1.79kg/hr
Supply Pressure		20 mbar		37 mbar	
Burner Operating Pressure		7.5 mbar (*)	6.0 mbar (*)	25.7 mbar (*)	25.5 mbar (*)
Gas Connection		3/4" BSP Male			

NOTE:

- * - Measure burner operating pressure at gas control outlet test point with burner operating at 'High' setting. Operating pressure is ex-factory set through appliance regulator and is not to be adjusted, apart from when carrying out gas conversion, if required. (Refer to 'Gas Conversion' section for details).

Specifications

Gas Connection

Gas supply connection point is located at rear of appliance, approximately 60mm from left hand side, 305mm from rear, 122mm from floor and is reached from beneath appliance. (Refer to 'Dimensions' section).

Connection is 3/4" BSP male thread.

Electrical Supply Requirements

G580-8 / G580-12 - 220-240V a.c, 50 / 60Hz, 0.1kW, 1P+N+E.
G580-8E / G580-12E - 220-240V a.c, 50 / 60Hz, 0.35kW, 1P+N+E.

Water Supply Requirements

Cold water connection is 1/2" tube connection via 15mm crox fitting located 280mm from LH side, 575mm from rear and 241mm from floor.

Water supply must be protected by an in line sediment filter / strainer, which should be fitted into pipeline prior to Bratt Pan water connection.

Maximum water supply pressure 550 kPa (80 psi).

Maximum inlet water temperature - 80°C.

Dimensions

Dimensions G580-8

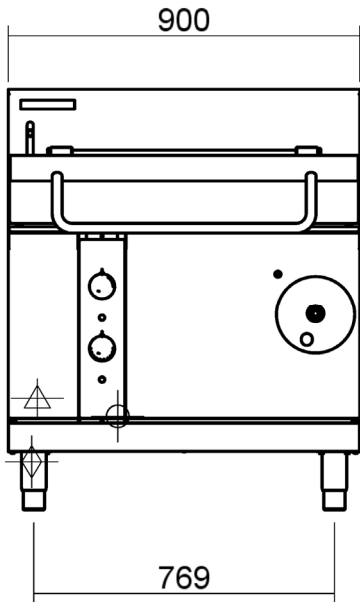

FRONT
G580-8

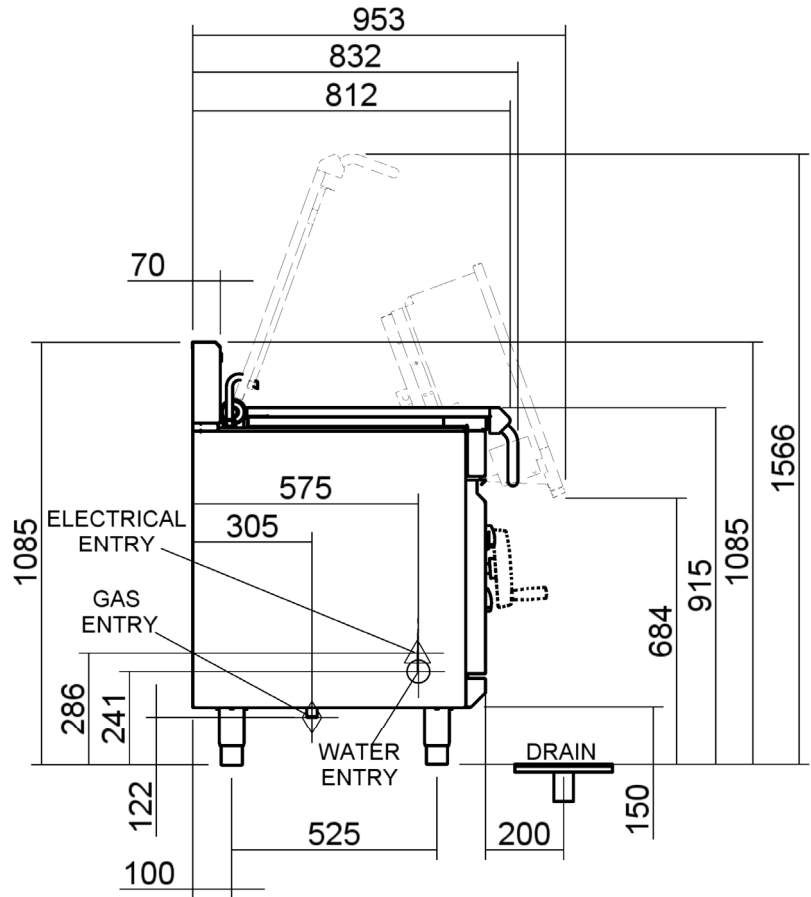

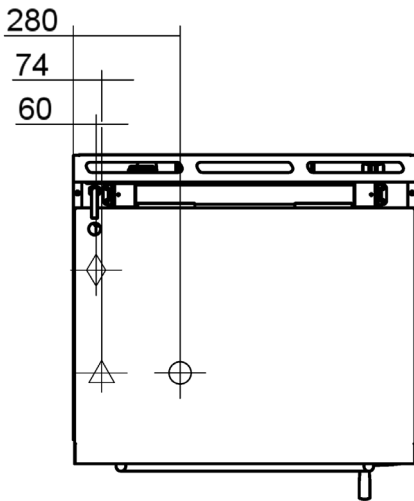

SIDE
G580-8



PLAN
G580-8



-  Electrical Connection Point.
-  Gas Connection Point.
-  Water Connection Point.

Dimensions

Dimensions G580-8E

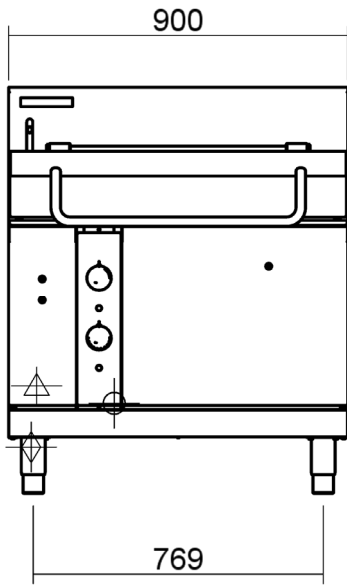

FRONT
G580-8E

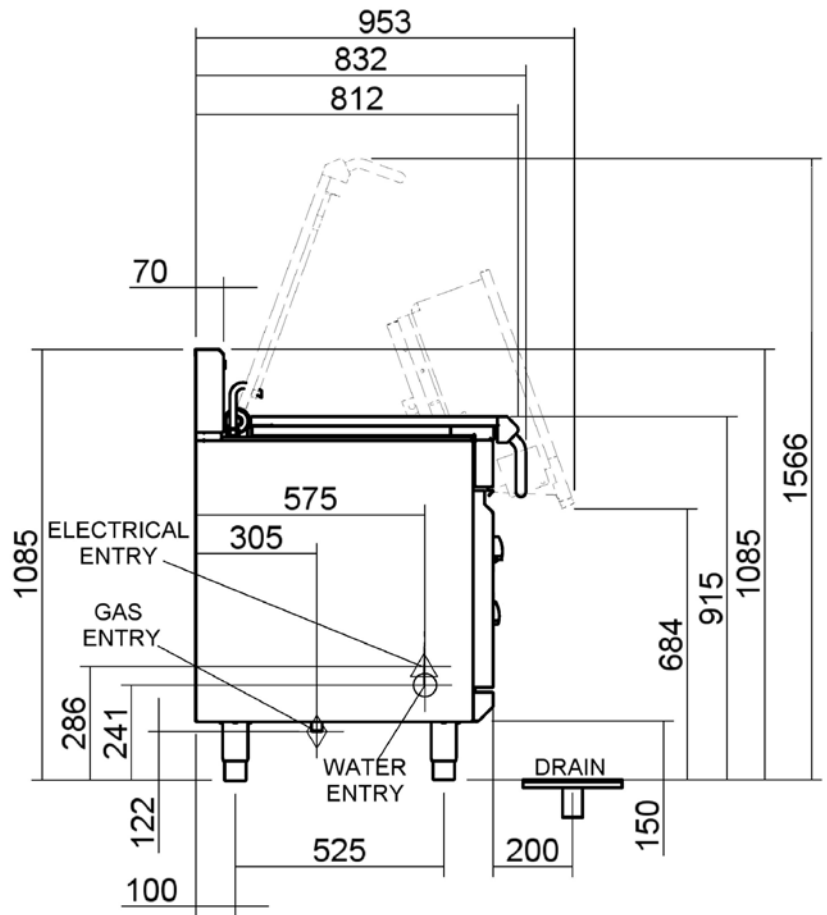

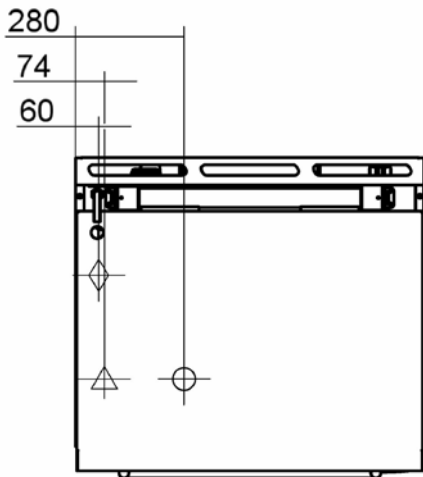

SIDE
G580-8E



PLAN
G580-8E



-  Electrical Connection Point.
-  Gas Connection Point.
-  Water Connection Point.

Dimensions

Dimensions G580-12

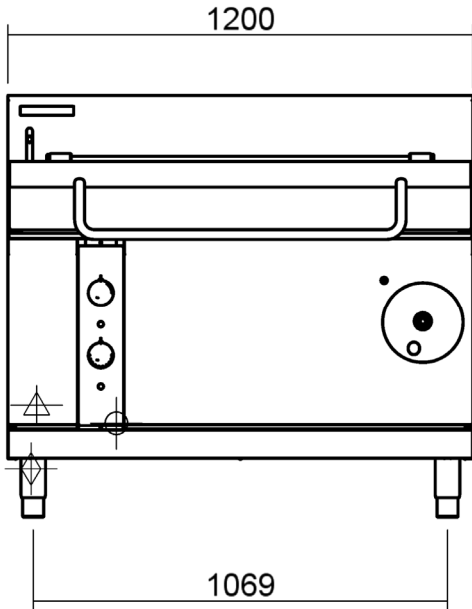

FRONT
G580-12

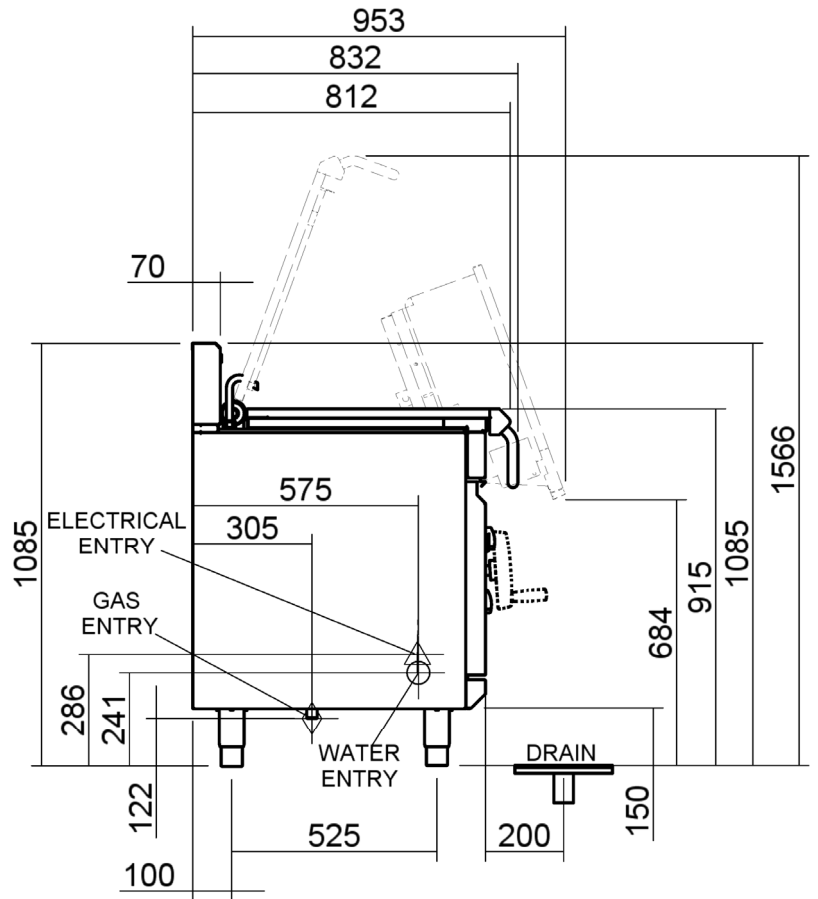

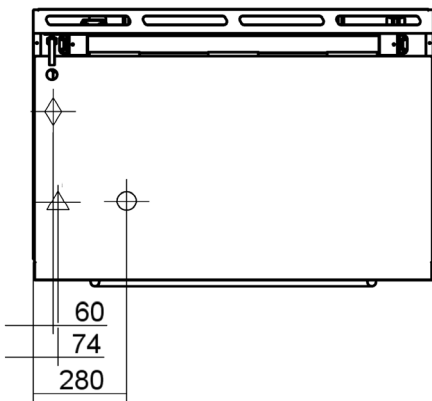

SIDE
G580-12



PLAN
G580-12



-  Electrical Connection Point.
-  Gas Connection Point.
-  Water Connection Point.

Dimensions

Dimensions G580-12E

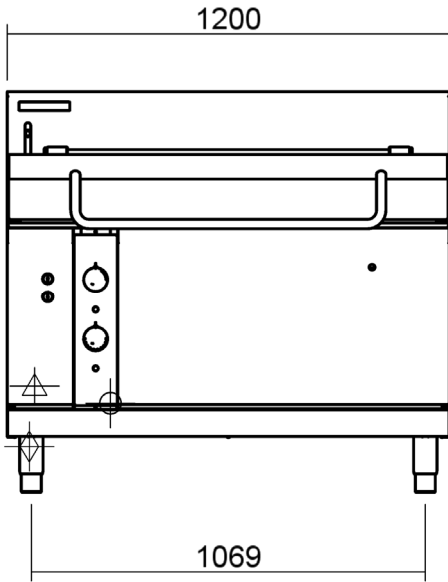

FRONT
G580-12E

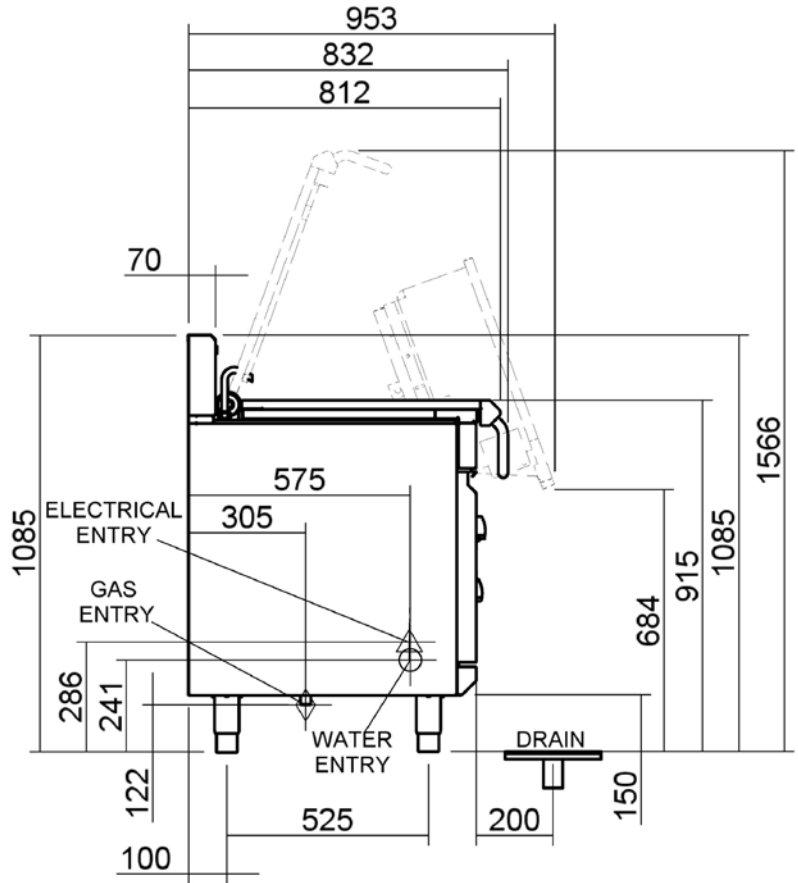

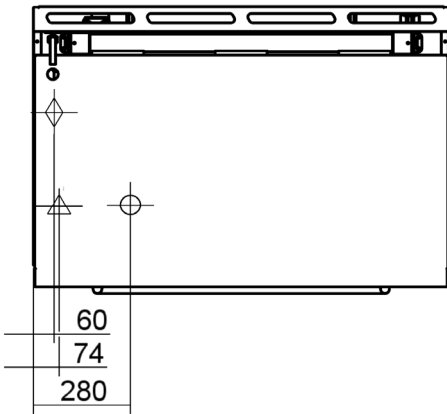

SIDE
G580-12E



PLAN
G580-12E



-  Electrical Connection Point.
-  Gas Connection Point.
-  Water Connection Point.

Installation Requirements

NOTE: It is most important that this appliance is installed correctly and that operation is correct before use. Installation shall comply with local gas, electrical and health and safety requirements.

Blue Seal Bratt Pans are designed to provide years of satisfactory service, and correct installation is essential to achieve the best performance, efficiency and trouble-free operation.

This appliance must be installed in accordance with National installation codes and in addition, in accordance with relevant National / Local codes covering gas, electrical, fire and health and safety.

Australia:	- AS5601	- Gas Installations.
New Zealand:	- NZS5261	- Gas Installation.
Australia / New Zealand:	- AS/NZS3000	- Wiring Rules.
	- AS / NZS 3500	- Plumbing and Drainage.
United Kingdom:	- Gas Safety (Installation & Use) Regulations 1998.	
	- BS6173	- Installation of Catering Appliances.
	- BS5440 1 & 2	- Installation Flueing & Ventilation.
	- BS7671	- Requirements for Electrical Installation.
Ireland:	- IS 820	- Non-Domestic Gas Installations.

Installations must be carried out by authorised persons only. Failure to install equipment to the relevant codes and manufacturer's specifications shown in this section will void the warranty.

Components having adjustments protected (e.g. paint sealed) by the manufacturer are only to be adjusted by an authorised service agent. They are not to be adjusted by the installation person.

Unpacking

- Remove all packaging.
- Check equipment and parts for damage. Report any damage immediately to the carrier and distributor.
- Ensure the 4 adjustable feet with the protruding centre screw are fitted.
- Remove protective plastic coating from side panels.
- Report any deficiencies to distributor who supplied bratt pan.
- Check available gas supply is correct to as shown on rating plate located on bottom corner of front right hand panel.

Location

1. Installation must allow for sufficient flow of fresh air for combustion air supply.

Combustion Air Requirements

	G580-8 / G580-8E	G580-12 / G580-12E
Natural Gas (G20)	19m ³ /hr	24m ³ /hr
LPG / Propane (G31)	20m ³ /hr	24m ³ /hr

2. Any gas burning appliance requires adequate clearance and ventilation for optimum and trouble-free operation.
3. Never directly connect a ventilation system to appliance flue outlet.
4. Installation must include adequate ventilation means, to prevent dangerous build up of combustion products.
5. Position Bratt Pan in its approximate working position.
6. All air for burner combustion is supplied from beneath the unit. Legs must always be fitted and no obstructions placed beneath or around base of appliance, as obstructions will cause incorrect operation and / or failure of appliance.

NOTE: Do not obstruct or block appliances flue. Never directly connect a ventilation system to appliance flue outlet.

Installation

Clearances

The following minimum installation clearances are to be adhered to:

	Combustible Surface	Non Combustible Surface
Left / Right hand side	50mm	0mm
Rear	50mm	0mm

NOTE: Only non-combustible materials can be used in close proximity to this appliance.

Assembly

NOTE:

- **This appliance must only be installed on adjustable feet supplied. It must not be fitted with rollers or castors as this appliance is intended for stationary installations only.**
- **Appliance must be positioned securely and level. This should be carried out on completion of gas connection. Refer to 'Gas Connection' section.**

Optional Accessories (Refer to Replacement Parts List)

- Plinth Kit. For installation details, refer to instructions supplied with each kit.

1. Check that all feet are in place and are tightened firmly.
2. Roughly adjust feet to make bratt pan steady and level.
3. To assemble handle to lid, unpack handle assembly. Place handle on outside of lid with curved part of handle facing downwards. (Refer to Fig 1).
4. Fit bolts with spring washers and flat washers from inside of lid and tighten bolts to secure handle in position.

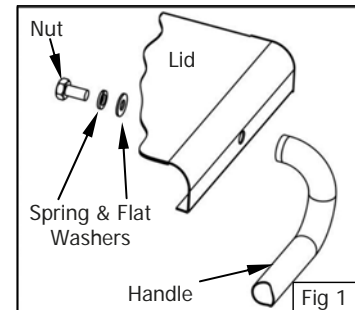

Gas Connection

NOTE: ALL GAS FITTING MUST ONLY BE CARRIED OUT BY AN AUTHORISED PERSON.

1. It is essential that gas supply is correct for appliance to be installed and that adequate supply pressure and volume are available. The following checks should be made before installation:-
 - a. **Gas Type** the appliance has been supplied for is shown on coloured stickers located above gas connection and on rating plate. Check that this is correct for gas supply appliance is being installed for. Gas conversion procedure is detailed in this manual.
 - b. **Supply Pressure** required for this appliance is shown in 'Specifications' section of this manual. Check gas supply to ensure adequate supply pressure exists.
 - c. **Input Rate** of this appliance is shown on Rating Plate and in 'Specifications' Section of this manual. Input rate should be checked against available gas supply line capacity. **Particular note should be taken if appliance is being added to an existing installation.**



NOTE: It is important that adequately sized piping runs directly to connection joint on appliance with as few tees and elbows as possible to give maximum supply volume.

2. Fit gas regulator supplied, into gas supply line as close to appliance as possible.

NOTE: Gas pressure regulator provided with this appliance is convertible between Natural Gas and LPG as shown in 'Gas Conversion Section' in this manual. Ensure regulator is converted to correct gas type that appliance will operate on. Regulator outlet pressure is fixed ex-factory for gas type that regulator is converted to and it is NOT to be adjusted.

Regulator connections are $\frac{3}{4}$ " BSP female.
Connection to appliance is $\frac{3}{4}$ " BSP male.

(Refer to 'Specifications' section for gas supply location dimensions).

NOTE: A Manual Isolation Valve must be fitted to individual appliance supply line.

3. Correctly locate appliance into its final operating position and using a spirit level, adjust legs so that unit is level and at correct height.
4. Connect gas supply to appliance. A suitable joining compound which resists breakdown action of LPG must be used on every gas line connection, unless compression fittings are used.
5. Check all gas connections for leakages using soapy water or other gas detecting equipment.



Warning

DO NOT USE A NAKED FLAME TO CHECK FOR GAS LEAKAGES.

6. Check gas operating pressure is as shown in 'Specifications' section.

NOTE: Operating pressure is to be measured at gas control outlet test point with burner operating at 'High Flame' setting.

7. Turn 'Off' mains gas supply and bleed gas out of appliance gas lines.
8. Turn 'On' gas supply and appliance.
9. Verify operating pressure remains correct.

Electrical Connection

1. Electrical systems are all connected through a 2m, 10 amp flex located at LH side of unit.
2. For immediate electric supply, plug lead into a properly earthed, 220-240V, 50 Hz, 1P+N+E, 3 pin socket.

Water Connection

NOTE:

- **Water supply must be protected by an in line sediment filter / strainer, which should be fitted into pipeline prior to Bratt Pan water connection.**
- **All water pipework must be thoroughly flushed prior to completion of installation procedure.**

Cold water mains $\frac{3}{4}$ " BSP male thread connection point. For location details on services connections refer to drawings in 'Specification' section.

- **Maximum water supply pressure - 550 kPa (80 psi).**
- **Maximum water supply temperature - 80°C.**

Remove control panel for access to cold water connection.



Installation

Commissioning

Before leaving the new installation;

Check the following functions in accordance with operating instructions shown in 'Operation' section of this manual.

- Ensure all water pipework has been thoroughly flushed through prior to using bratt pan.
- Light Pilot Burners.
- Light Main Burners.
- Check main burner operation 'ON' / 'OFF' with Thermostat Control.

Ensure operator has been instructed in areas of correct lighting, operation, and shutdown procedure for appliance.

This manual must be kept by owner for future reference, and a record of ***Date of Purchase, Date of Installation*** and ***Serial Number of Unit*** recorded and kept with this manual. **(These details can be found on Rating Plate attached to bottom corner of front right hand panel. Refer to 'Gas Connection' section).**

NOTE: If for some reason it is not possible to get appliance to operate correctly, shut 'Off' gas supply and contact supplier of this appliance.

Operation Guide



Caution

- **This appliance is for professional use and is only to be used by qualified persons.**
 - **Only authorised service persons are to carry out installation, servicing or gas conversion operations.**
 - **Components having adjustments protected (e.g. paint sealed) by the manufacturer should not be adjusted by the user / operator.**
-

1. Blue Seal bratt pans have been designed to provide simplicity of operation and 100% safety protection.
2. Improper operation is almost impossible, however bad operation practices can reduce life of bratt pan and produce a poor quality product. To use this bratt pan correctly please carefully read the following sections.
 - Description of Controls.
 - Lighting Pilot Burner.
 - Lighting Main Burner.
 - Setting Temperature.
 - Operating Water Supply Valve.
 - Tilting the Pan - G580-8 / G580-12 Models Only.
 - Tilting the Pan - G580-8E / G580-12E Model Only.
 - Turning Off the Bratt Pan.

Operation

Description of Controls

G580-8 / G580-12 Models.



**Manual Tilt Handwheel
(8 & 12 Models only)**



**Water Flow Control Valve
(All Models)**

○ OFF Position
Graduated Flow



**Gas Control Knobs
(All Models)**

☆ Pilot Burner
Graduations from 1 to 10
for heat control.

G580-8E / G580-12E Models.



Controls are as
for Models
shown above

Heating Indicator
Lamp (Amber)

Power Indicator
Lamp (White)



**Electrical Tilt Controls
(8E & 12E Models only)**

With bratt pan lid open, bratt
pan can be electrically raised to
'UP' position.

Lighting Pilot Burner

1. Ensure mains power and gas supply is turned 'On' at mains supply.
2. Push-in gas control knob and rotate anti-clockwise to PILOT position. Power indicator light (Green) should illuminate and ignitor should be heard operating.
3. Hold gas control knob depressed, igniter will continue to operate until pilot is alight.
4. Once pilot is lit (view through viewing port at front of bratt pan), continue holding 'IN' gas control knob for approximately 10 seconds, then release. The pilot burner should remain alight and ignitor should stop operating.
5. If pilot burner does not light, repeat Items 1 to 4 above.

NOTE: Pilot Burner can be lit with Bratt Pan in 'UP' or 'DOWN' position.

Lighting Main Burner

1. Once pilot burner is alight, main burner can be lit.
2. Rotate gas control knob anti-clockwise to desired temperature position.
3. Main burner will automatically ignite from pilot burner and temperature indicator (orange) will illuminate. Temperature indicator will only remain alight whilst main burner is operating, once bratt pan reaches desired temperature, temperature indicator (orange) will extinguish.

NOTE: Main Burner will only operate when Bratt Pan is in fully 'DOWN', cooking position. Tilting Bratt Pan will automatically 'Shut Off' Main Burner.

Setting the Temperature

1. Turn gas control knob to desired heat setting. Temperature will be thermostatically controlled at this selected heat setting.

NOTE: Pilot burner must be lit before heating system can be operated.

Operating the Water Supply Valve

1. Main power supply to bratt pan needs to be turned 'ON' to hold solenoid water supply valve open and allow water supply to bratt pan.
2. To add water to cooking product or for cleaning purposes, turn water tap anti-clockwise with pan in down position and pan lid up.
3. Water flow can be controlled by adjusting water control knob position.

NOTE: A ¼ turn anti-clockwise is FULLY open.

Tilting the Pan G580-8 / G580-12

NOTE: bratt pan lid must be raised before lifting pan to avoid damage to appliance.

1. To tilt pan, ensure water valve is in closed position.
2. Open bratt pan lid to raised position.
3. Flip out stored handle and lock into operating position.
4. Rotate handwheel clockwise to tilt bratt pan. If main burners are operating, these will automatically turn 'Off' as pan is raised.
5. With bratt pan returned to its 'Down' position, main burners will re-ignite.

Tilting the Pan G580-8E / G580-12E

NOTE: Bratt pan lid must be raised before lifting pan to avoid damage to appliance.

1. To tilt pan, ensure water valve is in closed position.
2. Open bratt pan lid to raised position.

Pull Out Stored Handle

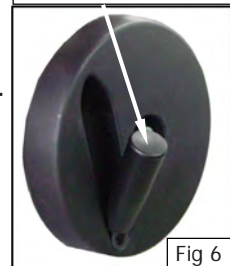

Operation

3. Depress pan tilt control 'UP' or 'DOWN' switches on front panel and hold pan tilt control switch depressed until pan has reached desired position. If main burners are operating, these will automatically turn 'Off' as pan is raised.
4. Releasing switch will stop tilt operation and pan will rest in chosen position.
5. With bratt pan returned to its 'Down' position, burners will re-ignite.

Turning 'OFF' the Bratt Pan (All Models)

1. To turn bratt pan to 'PILOT' burner position, set gas control knob to 'PILOT' position. Main burner will turn 'OFF' and pilot burner will remain lit.
2. To turn bratt pan 'OFF' completely, rotate gas control knob to 'OFF' position by depressing and turning gas control knob clockwise. Pilot burner will extinguish completely.
3. Turn 'OFF' electrical power to bratt pan at mains supply otherwise ignitor will continually attempt to ignite pilot.

NOTE: If gas supply is turned 'OFF' at mains supply and gas control knob on control panel is left in pilot position, with electrical power still 'ON' at bratt pan, ignitor will continue to operate and attempt to ignite pilot. Ensure that electrical power is also turned 'OFF' at mains supply.

IMPORTANT:

Should any abnormal operation like;

- ignition problems,
 - abnormal burner flame,
 - burner control problems,
 - partial or full loss of burner flame in normal operation, be noticed, appliance requires IMMEDIATE service by a qualified service person and should not be used until such service is carried out.
-

Cleaning and Maintenance

General



Caution

Always turn 'Off' electrical and gas supply before cleaning.

This appliance is not water proof.

Do not use water jet spray to clean interior or exterior of this appliance.

Clean bratt pan regularly. A clean bratt pan looks better, will last longer and will perform better. A dirty bratt pan will hinder transfer of heat from cooking surface to food. This will result in loss of cooking efficiency.



Caution

If cleaning detergents are allowed to enter inner parts of appliance, rusting will occur on pipe work, installation elements, heating elements, gas fittings and electrical components, this will cause premature failure of appliance.

NOTE:

- **DO NOT clean appliance using high pressure water or steam jets.**
- **DO NOT pour water directly over appliance.**
- **DO NOT use wire brushes. Clean pan regularly after each use.**
- **DO NOT use combustible liquids to clean appliance.**
- **DO NOT use harsh abrasive detergents, sharp scrapers, strong solvents or caustic detergents as they will damage appliance.**
- **DO NOT use any chloric or bleaching detergents to clean appliance.**
- **DO NOT use saline or sulfuric acid preparations for descaling appliance.**
- **Ensure protective gloves are worn during cleaning.**
- **Clean pan regularly after each use.**

After Each Use

Clean interior of pan regularly after each use. Do not use wire brushes on pan. Clean using a mild detergent and a hot water solution using soft cloth or a soft bristled brush. Dry appliance thoroughly using a dry clean cloth.

Clean exterior of bratt pan using a mild detergent and a hot water solution using soft cloth or a soft bristled brush.

Daily Cleaning

Clean bratt pan control panel using a soft cloth moistened with a solution of mild detergent and hot water. **DO NOT USE EXCESSIVE WATER.** Dry control panel thoroughly using a dry clean cloth.

Clean interior and exterior of bratt pan using a mild detergent and a hot water solution using soft cloth or a soft bristled brush. Do not use wire brushes on pan. Dry appliance thoroughly using a dry clean cloth.

Cleaning and Maintenance

Weekly Cleaning

NOTE:

- If bratt pan usage is very high, we recommend that weekly cleaning procedure is carried out more frequently.
- Ensure that protective gloves are worn during cleaning.
- DO NOT use harsh abrasive detergents, strong solvents, sharp scrapers or caustic detergents as they will damage surface of bratt pan.
- DO NOT use water on burners while they are still hot as cracking may occur. Allow these items to cool and remove for cleaning.
- DO NOT clean burners in a dishwasher.

Clean bratt pan control panel using a soft cloth moistened with a solution of mild detergent and hot water. DO NOT USE EXCESSIVE WATER. Dry control panel thoroughly using a dry clean cloth.

Thoroughly clean interior and exterior of bratt pan regularly. Do not use wire brushes on pan. Clean using a mild detergent and a hot water solution using soft cloth or a soft bristled brush. Dry appliance thoroughly using a dry clean cloth.

NOTE: To prevent rust forming on steel components, ensure that detergent or cleaning material has been entirely removed after each cleaning process.

Stainless Steel Surfaces

- a. Clean interior and exterior surfaces of bratt pan with hot water, a mild detergent solution and a soft scrubbing brush. Note that gas control knobs are a push fit onto gas and water control valve spindles and can be removed to clean front of control panel.
- b. Baked on deposits or discolouration may require a good quality stainless steel cleaner or stainless steel wool. Always apply cleaner when appliance is cold and rub in direction of grain.
- c. It should not be necessary to remove manual tilt mechanism handwheel for cleaning purposes.
- d. Dry all components thoroughly with a dry cloth and polish with a soft dry cloth.
- e. To remove any discolouration, use an approved stainless steel cleaner or stainless steel wool. Always rub in direction of grain.

Periodic Maintenance

NOTE: All maintenance operations should only be carried out by a qualified service person.

To achieve the best results, cleaning must be regular and thorough and all controls and mechanical parts should be checked and adjusted periodically by a qualified service person. If any small faults occur, have them attended to promptly. Don't wait until they cause a complete breakdown. It is recommended that the appliance is serviced every 6 months.

Fault Finding

This section provides an easy reference guide to the more common problems that may occur during operation of your equipment. The fault finding guide in this section is intended to help you correct, or at least accurately diagnose problems with your equipment.

Although this section covers the most common problems reported, you may encounter a problem not covered in this section. In such instances, please contact your local authorised service agent who will make every effort to help you identify and resolve the problem. Please note that the service agent will require the following information:-

- **Model Trade Name and Serial Number of Appliance. (both can be found on Technical Data Plate located on appliance.**

Fault	Possible Cause	Remedy
Igniter not sparking or sparking intermittently.	No power to appliance.	Check power supply to appliance.
	No power to ignitor circuit.	Check power to ignitor circuit. Check continuity through ignitor switch located on gas control and wiring to ignitor is secure. If this is correct, replace ignitor.
	Short in high tension lead.	Replace high tension lead.
	Spark arc can be seen at electrode insulator, rather than at electrode tip.	Replace electrode. Call service provider.
NOTE: If ignition system fails, pilot can be manually lit in interim until piezo circuit is repaired. A standard taper torch, matches or lighter can be used to manually light burner.		
Pilot burner will not light / stay alight.	Thermocouple connection loose.	Check thermocouple connection and repair.
	Thermocouple faulty.	Replace thermocouple.
	Pilot flame too small. - Gas pressure too low. - Partially blocked pilot injector.	Adjust pilot flame as shown in 'Gas Specifications'.
	Check gas control valve.	Gas control valve faulty, replace. Call service provider.
Delay in pilot burner igniting main burner.	Incorrect operating pressure	Check operating pressure.
	Incorrect supply pressure.	Check supply pressure.
	Pilot flame adjustment incorrect.	Adjust pilot flame as shown in 'Gas Specifications'.
	Pilot burner injector, wrong size.	Fit correct size pilot burner injector.
	Faulty gas control valve.	Replace gas control valve. Call service provider.
Ignitor sparking continuously.	If gas supply is turned 'OFF' at mains supply with gas control knob left in 'Pilot' position, with electrical power left 'ON' at mains, ignitor will continue to operate and attempt to ignite pilot.	Check gas control knob is turned to 'OFF' position and electrical power has been turned 'OFF' at mains. Call service provider.

Fault Finding

Fault	Possible Cause	Remedy
Over-temperature thermostat cuts out	<p>Over-temperature thermostat faulty.</p> <p>Control thermostat not maintaining set temperature.</p> <p>a. Thermostat out of calibration.</p> <p>b. Thermostat does not open on temperature rise.</p> <p>Thermostat opens on temperature rise but control valve does not respond.</p>	<p>If main burners cut out and power indicator light also drops below 320°C, replace over-temperature thermostat.</p> <p>Check continuity through thermostat leads, on temperature rise. If circuit does not open, replace thermostat.</p> <p>Check connections on gas control are correct. If correct, replace gas control valve. Call service provider.</p>
Main Burners do not ignite	<p>Check power is supplied to unit.</p> <p>Check pan is flat and that tilt microswitch is closed.</p> <p>Check thermostat setting is correct and gas control knob on main burner is set to 'ON' position.</p>	<p>Turn 'On' power.</p> <p>Adjust microswitch so that microswitch is activated when pan is fully down in flat (cooking position).</p> <p>Call service provider.</p>
<p>No pan filling water available.</p> <p><i>(Manual water fill valve has an electrical solenoid isolating valve fitted to supply side of water supply plumbing in appliance. Shut-off valve only opens water supply to manual valve when pan is in 'DOWN' position.)</i></p>	<p>With the pan in the down position and main water supply 'ON' and manual water control valve set to max flow, check solenoid valve has electrical power across its coil terminals. If solenoid coil has power, but no water available on turning manual valve, check coil for open circuit, short circuit and for solenoid coil burn-out.</p> <p>If solenoid coil is satisfactory, disconnect water connection and check inlet filter screen for foreign matter blockage.</p> <p>If there is no voltage to solenoid coil.</p>	<p>Replace solenoid.</p> <p>Clean and refit inlet filter.</p> <p>Check water valve microswitch. Check for electrical fault in pan lift microswitch circuit. A fault here is likely to also cause main burner to fail.</p> <p>Call service provider.</p>

Wiring Schematic

G580-8 / G580-12 (Manual Tilt Models)

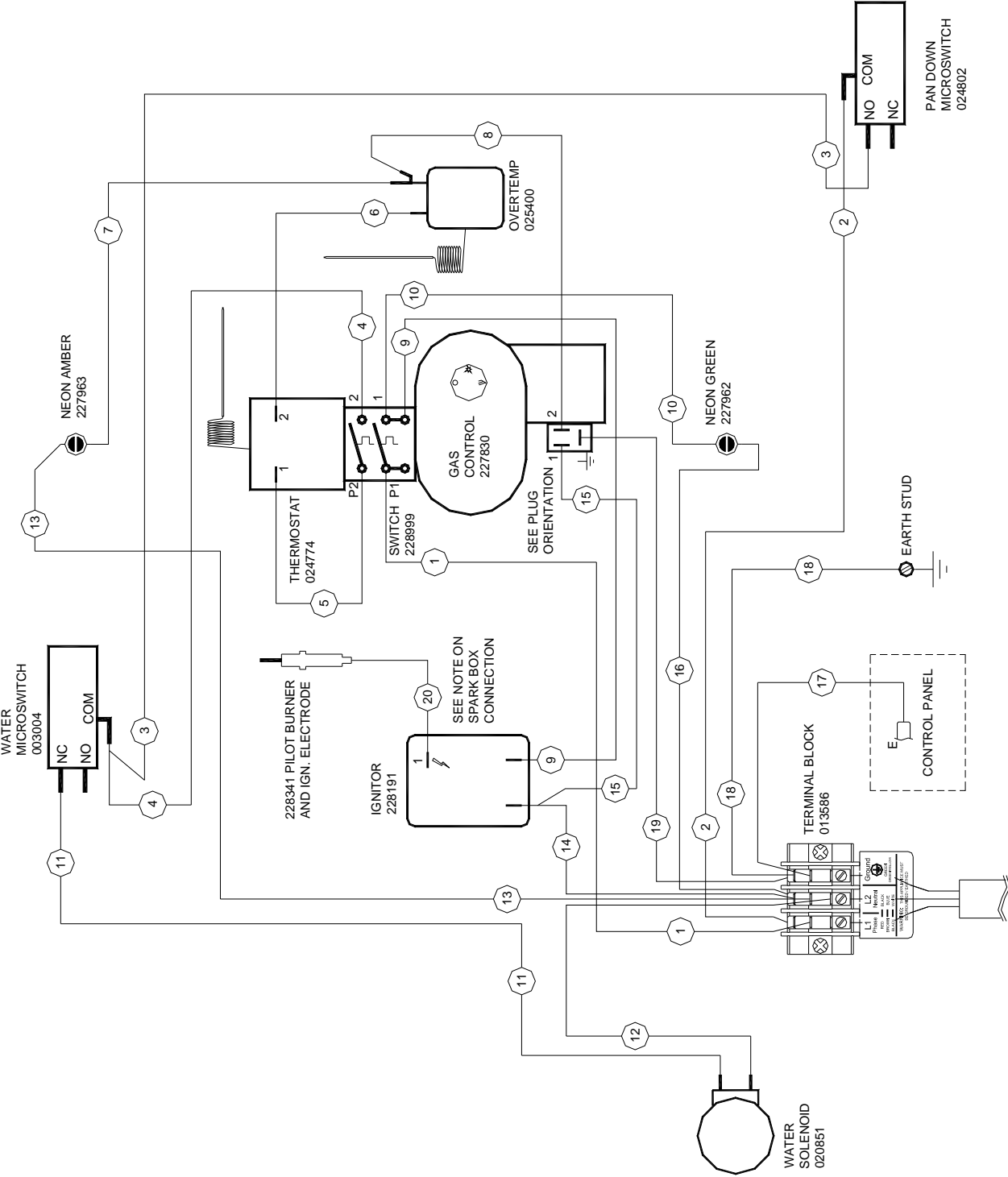

Wiring Schematic

G580-8E / G580-12E (Electric Tilt Models)

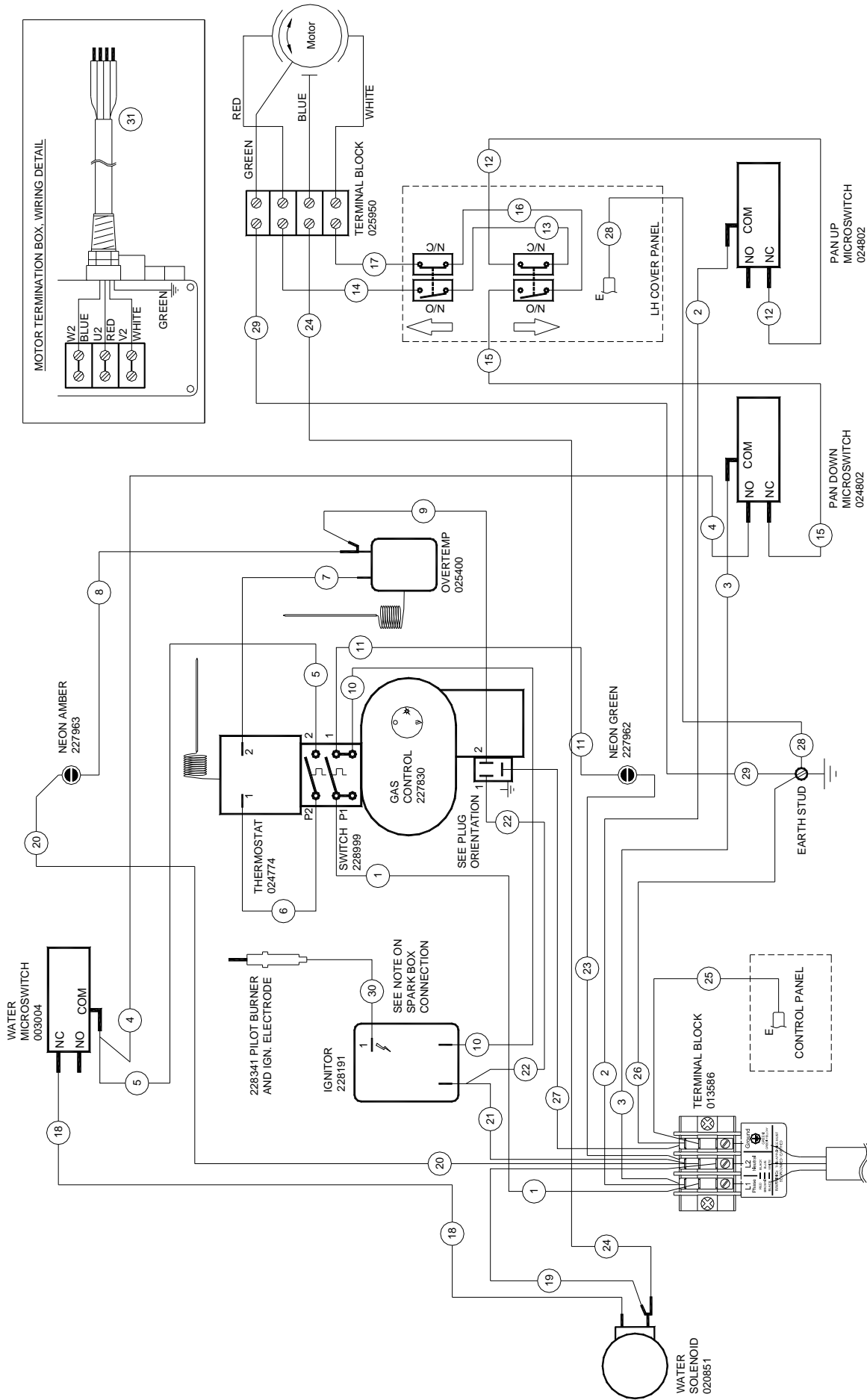

Conversion Procedure



Caution

Ensure Appliance is isolated from gas supply before commencing servicing.

NOTE:

- These conversions should only be carried out by qualified persons. All connections must be checked for leaks before re-commissioning appliance.
- Adjustment of components that have adjustments / settings sealed (e.g. paint sealed) should only be adjusted in accordance with the following instructions and should be re-sealed before re-commissioning this appliance.
- For all relevant gas specifications refer to the table at rear of this section.

Main Burner

Carry out the following actions:-

- Remove hand wheel (with pan in lowered position) **(G580-8 & G580-12 models only)**.
 - Remove gas and water control knobs.
 - Remove front control panel.
 - Remove large front right hand cover panel.
1. Refit hand wheel to allow pan to be raised / lowered during gas conversion procedure. **(G580-8 & G580-12 models only)**.
 2. Remove main burner injectors and replace with correct size injectors as shown in 'Gas Specification Tables' at rear of this section.
 3. Ensure aeration sleeve is adjusted to measurements shown in 'Gas Specification Tables'.

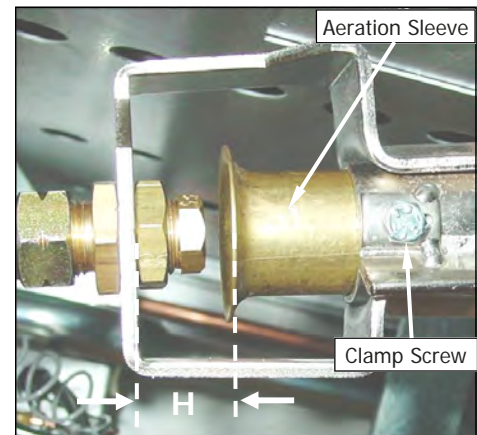
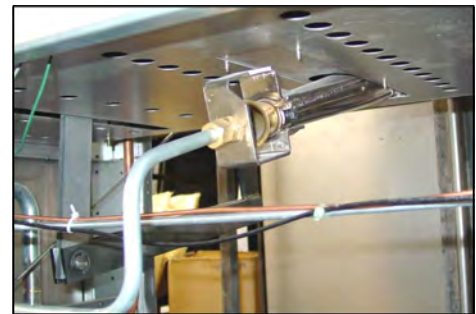

Pilot Burner

1. Disconnect the following:-
 - Pilot supply gas tube to pilot burner.
2. Remove pilot injector and replace with correct size injector as shown in 'Gas Specification' table at rear of this section.
3. Refit the following:-
 - Pilot supply tube to pilot burner.
 - Lower bratt pan, **(G580-8 & G580-12 models only)**.
 - Refit large front right hand cover panel.
 - Refit front control panel.
 - Refit gas and water control knobs.

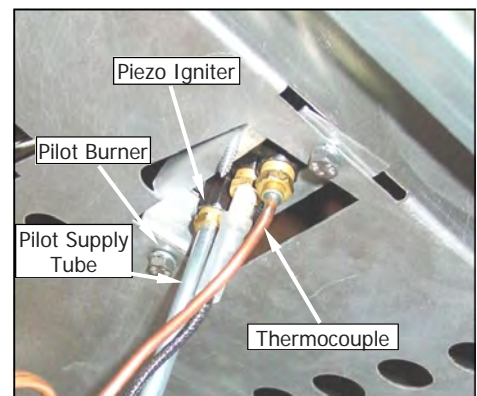

Gas Conversion and Specifications

Gas Regulator

NOTE: Gas regulator supplied is convertible between Natural Gas and LP Gas, but it's outlet pressure is fixed ex-factory and is NOT to be adjusted.

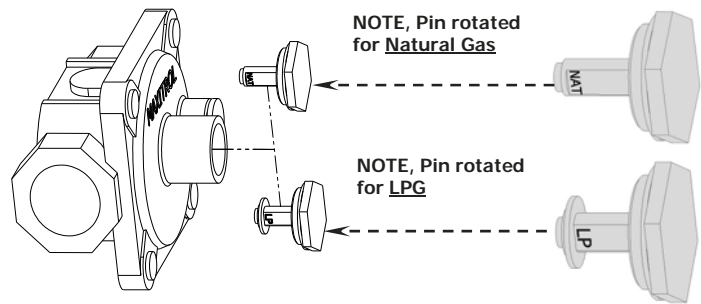

Gas Type Labels

On completion of gas conversion, replace gas type labels located at:-

- Rear of unit, above gas connection.
- Beside rating plate.

Commissioning

Before leaving installation;

1. Check all gas connections for leakage using soapy water or other gas detecting equipment.



Warning

DO NOT USE A NAKED FLAME TO CHECK FOR GAS LEAKAGES.



2. Carry out a 'Commissioning' check of appliance as shown in Installation Section of this manual.
3. Ensure any adjustments done to components that have adjustments / settings paint sealed are to be re-sealed.

NOTE: If for some reason it is not possible to get appliance to operate correctly, shut 'Off' gas supply and contact supplier of this appliance.

Gas Conversion and Specifications

Gas Specifications

- Australia / New Zealand Only:



	Natural Gas		LPG (Propane)	
	G580-8 / 8E	G580-12 / 12E	G580-8 / 8E	G580-12 / 12E
Main Burner Injector	Ø 4.30mm	Ø 5.20mm	Ø 2.50mm	Ø 2.80mm
Pilot Burner Injector	0.35		0.20	
Aeration Clearance (H)	30mm		30mm	
Supply Pressure	1.13 - 3.40kPa		2.75 - 4.50kPa	
Operating Pressure	0.76kPa (*)	0.60kPa (*)	2.4kPa (*)	2.5kPa (*)
Gas Regulator Cap Screw				

- UK Only:

Appliance Classification

Category: II_{2H3P}

Flue Type: A₁

	Natural Gas (G20)		LP Gas (Propane) (G31)	
	G580-8 / 8E	G580-12 / 12E	G580-8 / 8E	G580-12 / 12E
Main Burner Injector	Ø 4.30mm	Ø 5.20mm	Ø 2.50mm	Ø 2.80mm
Pilot Burner Injector	0.35		0.20	
Aeration Clearance (H)	30mm		30mm	
Supply Pressure	20mbar		37mbar	
Operating Pressure	7.5mbar (*)	6.0mbar (*)	25.7mbar (*)	25.5mbar (*)
Gas Regulator Cap Screw				

NOTE:

- * - Measure burner operating pressure at gas control outlet test point with **burner** operating at 'High' setting. Operating pressure is ex-factory set through appliance regulator and is not to be adjusted, apart from when carrying out gas conversion, if required. (Refer to 'Gas Conversion' section for details).

Replacement Parts List

Replacement Parts List

IMPORTANT:

Only genuine authorized replacement parts should be used for servicing and repair of this appliance. Instructions supplied with parts should be followed when replacing components.

For further information and servicing instructions, contact your nearest authorized service branch (contact details are as shown on reverse of front cover of this manual).

When ordering replacement parts, please quote part number and description as listed below. If part required is not listed below, request part by description and quote Model and Serial Number which is shown on rating plate.

Bratt Pan

228708	Main Burner	(G580-8 / G580-8E).
228709	Main Burner	(G580-12 / G580-12E).
038430	Burner Injector	Ø 4.30mm - Natural Gas (G580-8 / G580-8E).
038520	Burner Injector	Ø 5.20mm - Natural Gas (G580-12 / G580-12E).
038250	Burner Injector	Ø 2.50mm - LPG (G580-8 / G580-8E).
038280	Burner Injector	Ø 2.80mm - LPG (G580-12 / G580-12E).
228854	Pilot Burner Kit.	
026488	Pilot Injector	0.35 - Natural Gas.
018692	Pilot Injector	0.20 - LPG.
020253	Thermocouple.	
235421	H.T Lead Kit.	
228191	Ignitor.	
228706	Gas Control Assembly Kit.	
229355	Selector Switch c/w Insulator.	
013586	Terminal Block.	
025950	Terminal Block (Motor).	
024774	Thermostat 50°C - 320°C.	
025400	Over-Temp Thermostat.	
227963	Indicator Neon (Orange).	
228922	Indicator Neon (White).	
024802	Microswitch (Bratt Pan Raise - Lower).	
003004	Microswitch (Water Valve).	
020062	Water Control Valve.	
227915	Water Valve Lever.	
020851	Water Solenoid Valve.	
227841	Lid Handle - 650mm	(G580-8 / G580-8E Models Only).
227847	Lid Handle - 830mm	(G580-12 / G580-12E Models Only).
228716	Lid Hinge Spring Kit.	
227521	Tensioner Barrel.	
228824	Gas Control Knob (1 to 10 Graduations).	
227382	Water Control Knob.	
227857	Electric Motor	(8E & 12E Models Only).
020043	Bearing & Housing.	
228123	Handwheel.	
228117	Handwheel Spacer Bush.	
044400	Key Woodruff - $\frac{7}{8}$ " x $\frac{5}{32}$ ".	
044066	Handle Nut - M16 x 2.	
227850	Leg 150mm (Adjustable).	
228531	Regulator (Natural Gas / LP Gas [Propane] convertible) - $\frac{3}{4}$ " BSP F/F.	

Replacement Parts List

Gas Conversion Kits

Models	Gas Type to Convert to			
	Australia / New Zealand Only		UK Only	
	Nat. Gas (G20)	LPG (Propane) (G31)	Nat. Gas	Propane
G580-8 / 8E	232041	232040	232041	232040
G580-12 / 12E	232045	232044	232045	232044

Accessories

228798 Plinth Kit 900mm.
228802 Plinth Kit 1200mm.

