



EVOLUTIONSERIES

INSTALLATION AND OPERATION MANUAL

GAS CONVECTION OVEN RANGE

G54

G56

G58



Date Purchased _____

Serial Number _____

Dealer _____

Service Provider _____

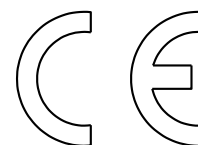

For use in GB, IE & DK

230105-16

MANUFACTURED BY

Moffat Limited

Rolleston 7675
New Zealand

INTERNATIONAL CONTACTS

AUSTRALIA

Moffat Pty Limited

Web: www.moffat.com.au
E.Mail: vsales@moffat.com.au
Main Office: (tel) +61 (03) 9518 3888
(fax) +61 (03) 9518 3838
Service: (tel): 1800 622 216
Spares: (tel): 1800 337 963
Customer Service: (tel): 1800 335 315
(fax): 1800 350 281

CANADA

Serve Canada

Web: www.servecanada.com
E.Mail: info@servecanada.com
Sales: (tel): 800 551 8795 (Toll Free)
Service: (tel): 800 263 1455 (Toll Free)

NEW ZEALAND

Moffat Limited

Web: www.moffat.co.nz
E.Mail: sales@moffat.co.nz
Main Office: (tel): 0800 663328

UNITED KINGDOM

Blue Seal

Web: www.blue-seal.co.uk
E.Mail: sales@blue-seal.co.uk
Sales: (tel): +44 121 327 5575
(fax): +44 121 327 9711
Spares: (tel): +44 121 322 6640
(fax): +44 121 327 9201
Service: (tel): +44 121 322 6644
(fax): +44 121 327 6257

UNITED STATES

Moffat

Web: www.moffat.com
Sales: (tel): 800 551 8795 (Toll Free)
(tel): +1 336 661 1556
(fax): +1 336 661 9546
Service: (tel): 800 858 4477 (Toll Free)
(tel): +1 336 661 1556
(fax): +1 336 661 1660

REST OF WORLD

Moffat Limited

Web: www.moffat.co.nz
E.Mail: export@moffat.co.nz

The reproduction or copying of any part of this manual by any means whatsoever is strictly forbidden unless authorized previously in writing by the manufacturer.

In line with policy to continually develop and improve its products, Moffat Ltd. reserves the right to change the specifications and design without prior notice.

© Copyright Moffat Ltd. December 2014.

Blue Seal Gas Range Convection Oven

- G54 Gas Convection Oven Range - 750mm wide.
- G56 Gas Convection Oven Range - 900mm wide.
- G58 Gas Convection Oven Range - 1200mm wide.

Introduction	2
Specification.....	3
Model Numbers Covered in this Specification	
General	
Gas Supply Requirements	
Gas Connection	
Electrical Supply Requirements	
Dimensions.....	6
Installation.....	9
Installation Requirements	
Unpacking	
Location	
Clearances	
Assembly	
Gas Connection	
Electrical Connection	
Commissioning	
Operation	12
Operation Guide	
Description of Controls	
Open Burners	
Griddles	
Oven Pilot Ignition	
Oven - Main Burner / Thermostat	
Oven Fan	
Turning the Oven to 'Stand-By' (Pilot 'ON' Only)	
Oven 'Shut Down'	
Cleaning and Maintenance.....	16
Before Commencing Cleaning	
Open Burner Cleaning	
Griddle Plate Cleaning	
Oven Interior Cleaning	
Stainless Steel Surfaces	
Fault Finding	19
Wiring Schematic	20
Gas Conversion and Specifications	21
Conversion Procedure	
Gas Specifications	
Replacement Parts List	27

Introduction

We are confident that you will be delighted with your BLUE SEAL Gas Range Convection Oven , , and it will become a most valued appliance in your commercial kitchen.

To ensure you receive the utmost benefit from your new Blue Seal appliance, there are two important things you can do.

Firstly:

Please read the instruction book carefully and follow directions given. The time taken will be well spent.

Secondly:

If you are unsure of any aspect of the installation, instructions or performance of your appliance, contact your BLUE SEAL dealer promptly. In many cases a phone call could answer your question.

CE Only:

These instructions are only valid if the country code appears on the appliance. If the code does not appear on the appliance, refer to the supplier of this appliance to obtain the technical instructions for adapting the appliance to the conditions for use in that country.



Warning

IMPROPER INSTALLATION, ADJUSTMENT, ALTERATION, SERVICE OR MAINTENANCE CAN CAUSE PROPERTY DAMAGE, INJURY OR DEATH. READ THE INSTALLATION, OPERATING AND MAINTENANCE INSTRUCTIONS THOROUGHLY BEFORE INSTALLING OR SERVICING THIS APPLIANCE.



Warning

INSTRUCTIONS TO BE FOLLOWED IN THE EVENT THE USER SMELLS GAS ARE TO BE POSTED IN A PROMINENT LOCATION. THIS INFORMATION SHALL BE OBTAINED BY CONSULTING THE LOCAL GAS SUPPLIER.



Warning

GREAT CARE MUST BE TAKEN BY THE OPERATOR TO USE THE EQUIPMENT SAFELY TO GUARD IT AGAINST RISK OF FIRE.

- **THE APPLIANCE MUST NOT BE LEFT ON UNATTENDED.**
 - **IT IS RECOMMENDED THAT A REGULAR INSPECTION IS MADE BY A COMPETENT SERVICE PERSON TO ENSURE CORRECT AND SAFE OPERATION OF YOUR APPLIANCE IS MAINTAINED.**
 - **DO NOT STORE OR USE GASOLINE OR OTHER FLAMMABLE VAPOURS OR LIQUIDS IN THE VICINITY OF THIS OR ANY OTHER APPLIANCE.**
 - **DO NOT SPRAY AEROSOLS IN THE VICINITY OF THIS APPLIANCE WHILE IT IS IN OPERATION.**
-



Caution

- **This appliance is for professional use and is only to be used by qualified persons.**
 - **Only authorised service persons are to carry out installation, servicing or gas conversion operations.**
 - **Components having adjustments protected (e.g. paint sealed) by the manufacturer should not be adjusted by the user / operator.**
 - **DO NOT operate the appliance without the legs supplied fitted.**
-

Model Numbers Covered in this Specification

G54D[1]	4 Open Burners + Turbofan Convection Oven.
G54C[1]	2 Open Burners + 300mm Griddle + Turbofan Convection Oven.
G56D[1]	6 Open Burners + Turbofan Convection Oven.
G56C[1]	4 Open Burners + 300mm Griddle + Turbofan Convection Oven.
G56B[1]	2 Open Burners + 600mm Griddle + Turbofan Convection Oven.
G56A	900 mm Griddle + Turbofan Convection Oven.
G58D[1]	8 Open Burners + Turbofan Convection Oven.
G58C[1]	6 Open Burners + 300mm Griddle + Turbofan Convection Oven.
G58B[1]	4 Open Burners + 600mm Griddle + Turbofan Convection Oven.
G58A	2 Open Burners + 900mm Griddle + Turbofan Convection Oven.

[1] - Open Burner Options;

- F - With Flame Failure Protection.
- PF - With Pilot and Flame Failure Protection.

General

A heavy duty, general purpose gas range created for compact modular kitchens. It has a high option Cook Top / Griddle arrangement and is available on industrial adjustable feet or on robust rollers.

Open Burners are available in either 'PF' (Pilot and Flame Failure) or 'F' (Flame Failure Only) options. Open Burner and Griddle options are fitted with individual flame failure for each open burner.

Griddles are fitted with pilot, flame failure and piezo ignition as standard.

Range is fitted with a turbofan convection oven which has pilot and flame failure with piezo ignition.

Easy clean stainless external finish.

Specifications

Gas Supply Requirements

- Australia:

	Natural Gas	LP Gas (Propane)
Input Rate (N.H.G.C.)		
- each Open Burner	28 MJ/hr	28 MJ/hr
- each 300mm Griddle Section	21 MJ/hr	21 MJ/hr
- Oven	30 MJ/hr	30 MJ/hr
Supply Pressure	1.13 - 3.40 kPa	2.75 - 4.50 kPa
Burner Operating Pressure (*)	0.95 kPa	2.6 kPa
Gas Connection	3/4" B.S.P. Male	

- New Zealand:

	Natural Gas	LP Gas
Input Rate (N.H.G.C.)		
- each Open Burner	28 MJ/hr	28 MJ/hr
- each 300mm Griddle Section	21 MJ/hr	21 MJ/hr
- Oven	30 MJ/hr	30 MJ/hr
Supply Pressure	1.13 - 3.40 kPa	2.75 - 4.50 kPa
Burner Operating Pressure (*)	0.95 kPa	2.6 kPa
Gas Connection	3/4" B.S.P. Male	

- UK Only:

Category: I₂H₃P (20, 37).
Flue Type: A₁.

		Natural Gas (G20)			Propane (G31)		
		Open Burner (each)	Griddle (each 300mm section)	Oven	Open Burner (each)	Griddle (each 300mm section)	Oven
Heat Input (nett)	Nominal	6.5 kW	5.5 kW	7.8 kW	6.5 kW	5.5 kW	7.8 kW
	Reduced	1.75 kW	1.85 kW	---	1.75 kW	1.95 kW	---
Gas Rate (nett)	Nominal	0.69 m ³ /hr	0.58 m ³ /hr	0.83 m ³ /hr	0.51 kg/hr	0.43 kg/hr	0.61 kg/hr
	Reduced	0.19 m ³ /hr	0.20 m ³ /hr	---	0.14 kg/hr	0.15 kg/hr	---
Supply Pressure		20 mbar			37 mbar		
Burner Operating Pressure (*)		9.5 mbar			26 mbar		
Gas Connection		3/4" B.S.P. Male					

* Measure burner operating pressure at manifold test point with two burners operating at full setting. Operating pressure is ex-factory set through the appliance regulator and is not to be adjusted, apart from when carrying out gas conversion, if required. (Refer to 'Gas Conversion' section for details).

- All Other Markets:

	Natural Gas	Town Gas (**)
Input Rate (N.H.G.C.)		
- each Open Burner	28MJ/hr	28MJ/hr
- each 300mm Griddle Section	21MJ/hr	21MJ/hr
- Oven	30 MJ/hr	30 MJ/hr
Supply Pressure	1.13 - 3.40kPa	0.75 - 1.50kPa
Burner Operating Pressure (*)	0.95kPa	0.63 Pa
Gas Connection	See 'Gas Connection' information overleaf	

	LP Gas (Propane)	Butane
Input Rate (N.H.G.C.)		
- each Open Burner	28MJ/hr	28MJ/hr
- each 300mm Griddle Section	21MJ/hr	21MJ/hr
- Oven	30 MJ/hr	30 MJ/hr
Supply Pressure	2.75 - 4.50kPa	2.75 - 4.50kPa
Burner Operating Pressure (*)	2.6kPa	2.6kPa
Gas Connection	See 'Gas Connection' information overleaf	

NOTE:

- (*) Measure Burner operating pressure at manifold test point with 2 burners operating at 'High Flame' setting.
- NAT, LPG & Butane Only - Operating pressure is ex-factory set and is not to be adjusted, unless when converting between gases, if required.
- (**) TOWN GAS Only - Adjust burner operating pressure using adjustable gas regulator supplied.
- Refer to 'Gas Conversion and Specifications' section in this manual for further details.

Gas Connection

Gas supply connection point is located at rear of appliance, approximately 130mm from right hand side, 32mm from rear and 655mm from floor and is reached from beneath appliance. (Refer to 'Dimensions' section).

Connection is 3/4" BSP male thread.

Electrical Supply Requirements

230-240 V a.c, 50 Hz, 1.6A, 1P+N+E.
0.4kW.

Oven Fan Motor - 100W.

Dimensions

Dimensions G54

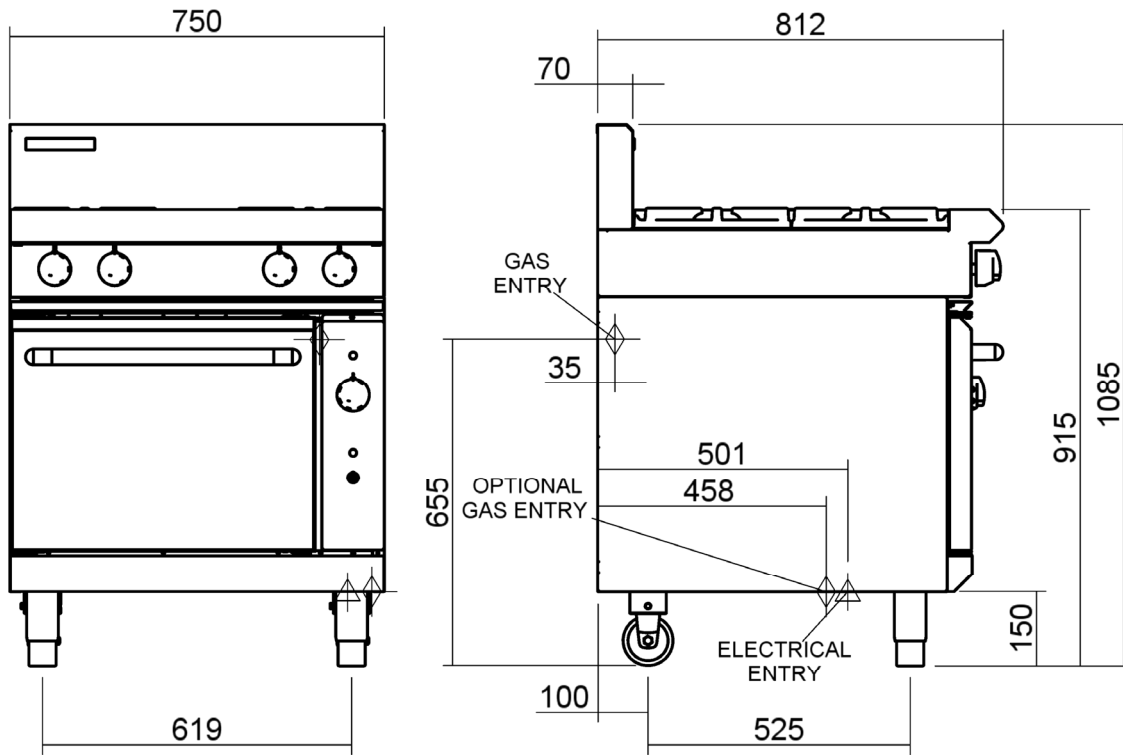

Cook Top Options G54D

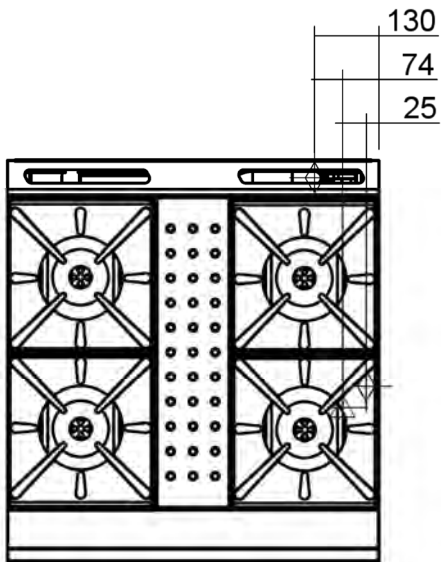

Cook Top Options G54C

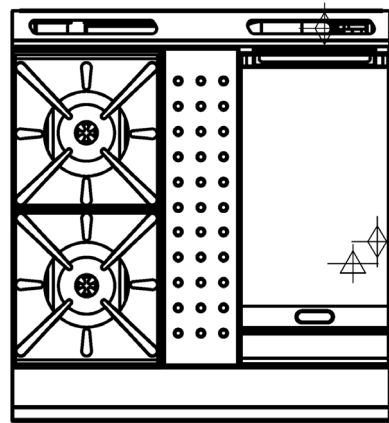

Dimensions G56D, G56C, G56B & G56A Models

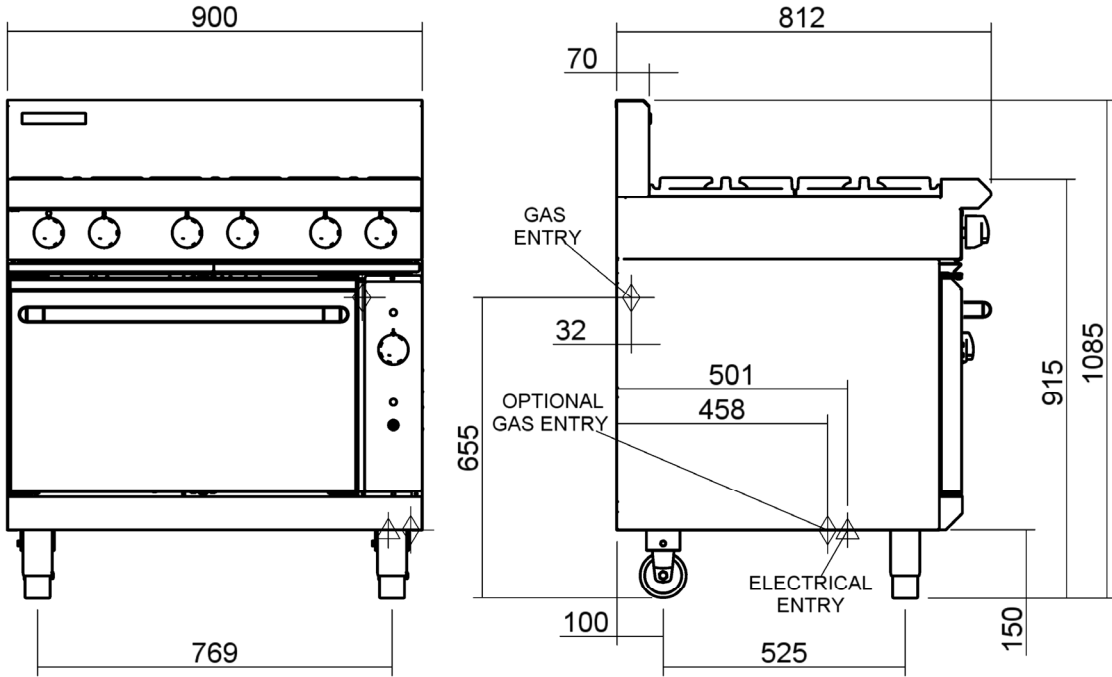

Cook Top Options G56D

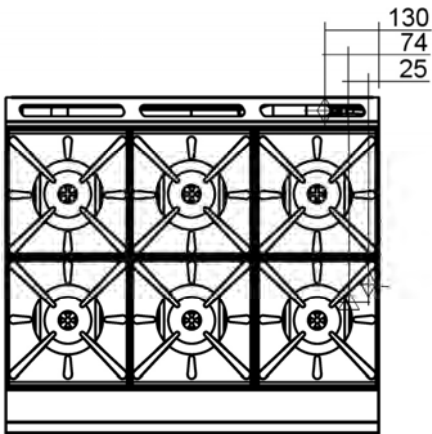

Cook Top Options G56C

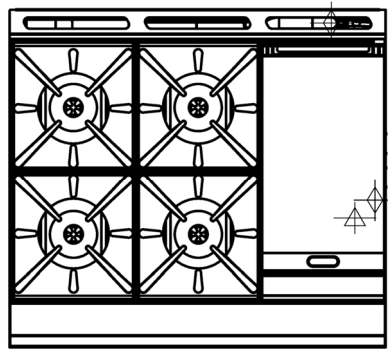

Cook Top Options G56B

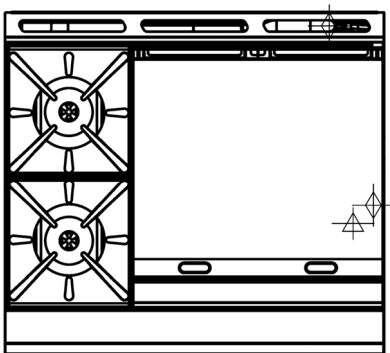

Cook Top Options G56A

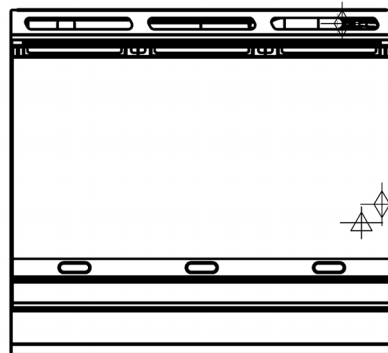

Dimensions

Dimensions G58D, G58C, G58B & G58A Models

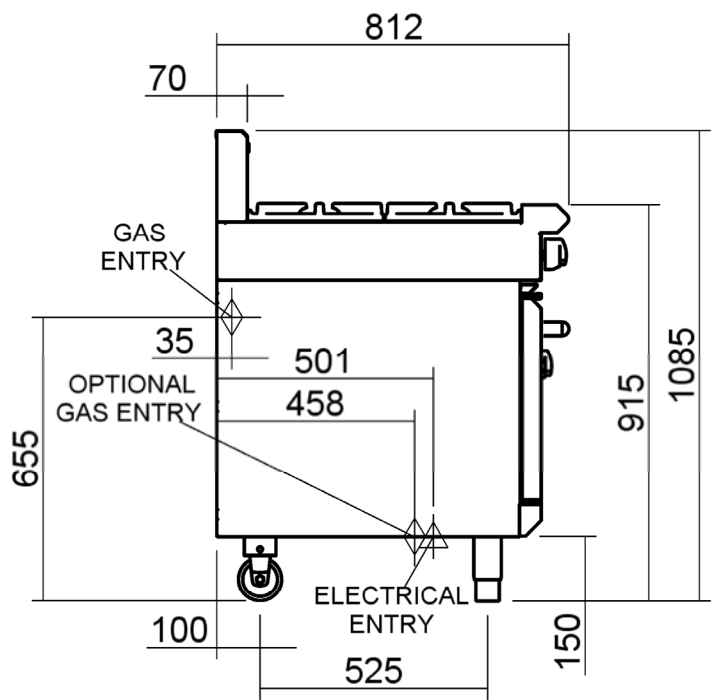
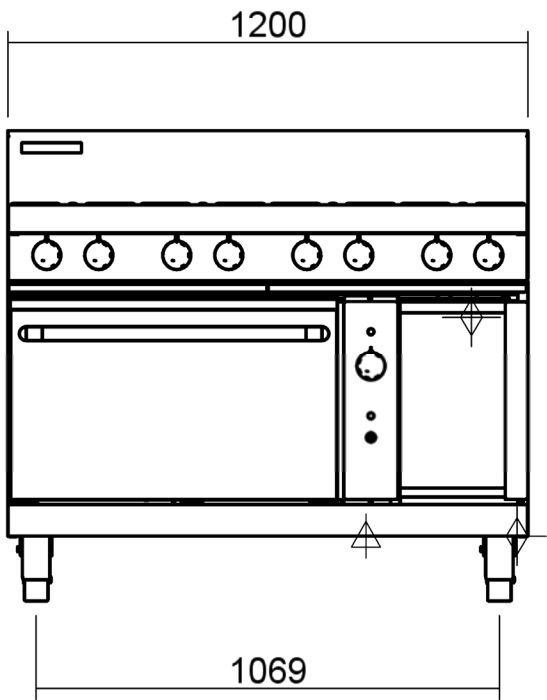

Cook Top Options G58D

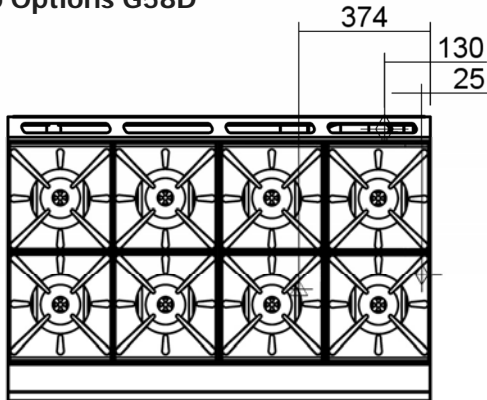

Cook Top Options G58C

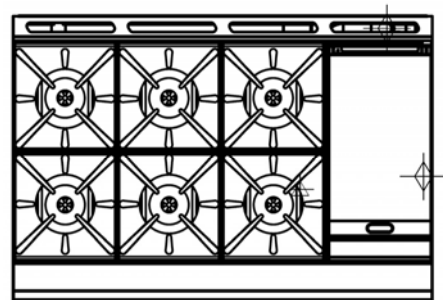

Cook Top Options G58B

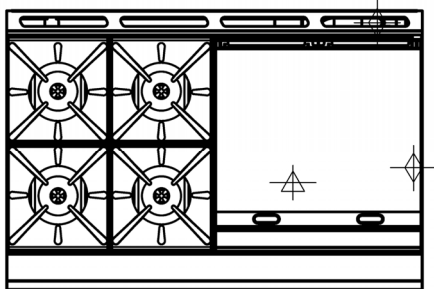

Cook Top Options G58A

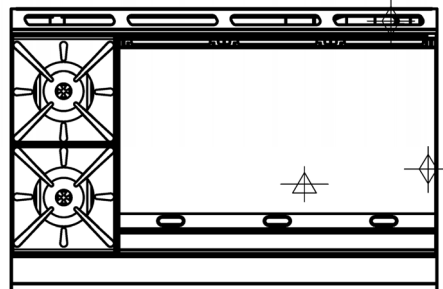

Installation Requirements

NOTE:

- It is most important that this appliance is installed correctly and that operation is correct before use. Installation shall comply with local gas, electrical and health and safety requirements.
- This appliance shall be installed with sufficient ventilation to prevent occurrence of unacceptable concentrations of health harmful substances in room, appliance is installed in.

Blue Seal Gas Range Convection Ovens are designed to provide years of satisfactory service, and correct installation is essential to achieve the best performance, efficiency and trouble-free operation.

This appliance must be installed in accordance with National installation codes and in addition, in accordance with relevant National / Local codes covering gas, electrical and fire safety.

AUSTRALIA:	- AS 5601	- Gas Installations.
NEW ZEALAND:	- NZS 5261	- Gas Installation.
Australia / New Zealand:	- AS/NZS 3000	- Wiring Rules.
UNITED KINGDOM:	- Gas Safety (Installation & Use) Regulations 1998.	
	- BS 6173	- Installation of Catering Appliances.
	- BS 5440 1 & 2-	- Installation Flueing & Ventilation.
	- BS 7671	- Requirements for Electrical Installation.
IRELAND:	- IS 820	- Non - Domestic Gas Installations.

Installation must be carried out by authorised persons only. Failure to install equipment to relevant codes and manufacturer's specifications shown in this section will void the warranty.

Components having adjustments protected (e.g. paint sealed) by manufacturer are only to be adjusted by an authorised service agent. They are not to be adjusted by the installation person.

Unpacking

- Remove all packaging and transit protection from appliance including all protective plastic coating from exterior stainless steel panels.
- Check equipment and parts for damage. Report any damage immediately to carrier and distributor.
- Report any deficiencies to distributor who supplied appliance.
- Check that available gas and electrical supply is correct to as shown on rating plate located on front right hand corner of bottom sill.

Location

1. Installation must allow for a sufficient flow of fresh air for the combustion air supply.

Combustion Air Requirements:			
	G54	G56	G58
Natural Gas	37 m ³ /hr	51 m ³ /hr	66 m ³ /hr
LPG / Butane	38 m ³ /hr	53 m ³ /hr	68 m ³ /hr
Town Gas	37 m ³ /hr	51 m ³ /hr	66 m ³ /hr

2. Installation must include adequate ventilation means, to prevent dangerous build up of combustion products.
3. Never directly connect a ventilation system to appliance flue outlet.
4. Position appliance in its approximate working position.
5. All air for burner combustion is supplied from underneath appliance. Legs must always be fitted and no obstructions placed under or around base of the appliance, as obstructions will cause incorrect operation and / or failure of the appliance.

NOTE: Do not obstruct or block the appliances flue. Never directly connect a ventilation system to the appliance flue outlet.

Installation

Clearances

NOTE: Only non-combustible materials can be used in close proximity to this appliance.

	Combustible Surface	Non Combustible Surface
Left / Right hand side	250mm (*)	0mm
Rear	100mm	0mm

* Side clearances can be 50mm when the adjacent surface is at least 100mm below cooking surface.

Assembly



Caution

- **This appliance is for professional use and is only to be used by qualified persons.**
- **Only authorised service persons are to carry out installation, servicing or gas conversion operations.**

NOTE:

- **All Models are delivered completely assembled. No further assembly is required.**
- **This appliance is fitted with adjustable feet to enable appliance to be positioned securely and level. This should be carried out on completion of gas connection. Refer to 'Gas Connection' section.**

Optional Accessories (Refer to Replacement Parts List)

- Plinth Kit. For installation details, refer to instructions supplied with each kit.
- Rear Adjustable Legs.

1. Check that all feet (or castors) are securely fitted.
2. Adjust feet to make convection oven range steady and level.

Gas Connection

NOTE: ALL GAS FITTING MUST ONLY BE CARRIED OUT BY AN AUTHORISED PERSON.

1. It is essential that gas supply is correct for appliance being installed and that adequate supply pressure and volume are available. The following checks should be made before installation:-
 - a. **Gas Type** the appliance has been supplied for is shown on coloured stickers located above gas connection and on rating plate. Check that this is correct for gas supply, appliance is being installed for. Gas conversion procedure is detailed in this manual.
 - b. **Supply Pressure** required for this appliance is shown in 'Specifications' section of this manual. Check gas supply to ensure adequate supply pressure exists.
 - c. **The Input Rate** of this appliance is shown on Rating Plate and in 'Specifications' section of this manual. Input rate should be checked against available gas supply line capacity. **Particular note should be taken if appliance is being added to an existing installation.**



NOTE: It is important that adequately sized piping runs directly to connection joint on appliance with as few tees and elbows as possible to give maximum supply volume.

2. Fit gas regulator supplied, into gas supply line as close to appliance as possible.

NOTE: Gas pressure regulator provided with this appliance is convertible between Natural Gas and LPG as shown in 'Gas Conversion Section' in this manual. Ensure regulator is converted to correct gas type that appliance will operate on. Regulator outlet pressure is fixed ex-factory for gas type that regulator is converted to and it is NOT to be adjusted.

Regulator connections are $\frac{3}{4}$ " BSP female.

Connection to appliance is $\frac{3}{4}$ " BSP male.

(Refer to 'Specifications' section for gas supply location dimensions).

NOTE: A Manual Isolation Valve must be fitted to individual appliance supply line.

3. Correctly locate appliance into its final operating position and using a spirit level, adjust legs so that appliance is level and at correct height.
4. Connect gas supply to appliance. A suitable jointing compound which resists breakdown action of LPG must be used on every gas line connection, unless compression fittings are used.
5. Check all gas connections for leakages using soapy water or other gas detecting equipment.



Warning

DO NOT USE A NAKED FLAME TO CHECK FOR GAS LEAKAGES.

6. Check gas operating pressure is as shown in the 'Specifications' section.

NOTE: Measure burner operating pressure at manifold test point with two burners operating at 'Full' setting.

7. Verify operating pressure remains correct.

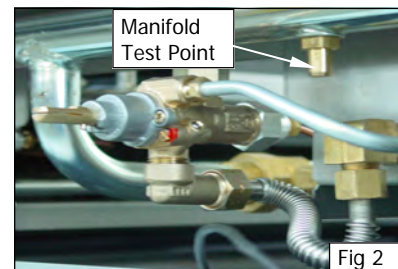

Fig 2

Electrical Connection

NOTE: ALL ELECTRICAL CONNECTIONS MUST ONLY BE CARRIED OUT BY AN AUTHORISED PERSON.

Each appliance should be connected to an adequately protected power supply and isolation switch mounted adjacent to, but not behind appliance. This switch must be clearly marked and readily accessible in case of fire.

1. Check electricity supply is correct as shown on Rating Plate attached to front right hand corner of bottom sill.
2. Appliance is fitted with a 10 Amp, 3 pin plug cordset for connection to a properly earthed, 3 pin switched electrical socket.

Commissioning

1. Before leaving the new installation;
 - a. Check the following functions in accordance with operating instructions specified in 'Operation' section of this manual.
 - Lighting the Griddle.
 - Light the Open Burners. (F - Flame Failure Option).
 - Light the Open Burners. (PF - Pilot and Flame Failure Option).
 - Check the Low Fire Burner operation.
 - Check the High Fire Burner operation.
 - Light the Oven Pilot and Main Burners.
 - Check the Oven Main Burner Thermostat operation.
 - Check the Oven Fan operation.
 - b. Ensure operator has been instructed in areas of correct lighting, operation, and shutdown procedure for appliance.
2. This manual must be kept by owner for future reference, and a record of ***Date of Purchase, Date of Installation*** and ***Serial Number of Appliance*** recorded and kept with this manual. (***These details can be found on Rating Plate attached to front right hand corner of bottom sill. Refer to 'Gas Connection' section.***)

NOTE: If it is not possible to get appliance to operate correctly, shut off gas supply and contact supplier of this appliance.

Operation

Operation Guide

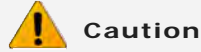

Caution

- This appliance is for professional use and is only to be used by qualified persons.
- Only authorised service persons are to carry out installation, servicing or gas conversion operations.
- Components having adjustments protected (e.g. paint sealed) by the manufacturer should not be adjusted by the user / operator.

1. Blue Seal appliances have been designed to provide simplicity of operation and 100% safety protection.
2. Improper operation is almost impossible, however bad operating practices can reduce the life of the appliance and produce a poor quality product. To use this appliance correctly please read the following sections carefully:-

- Lighting the Open Burners (F - Flame Failure Option).
- Lighting the Open Burners (PF - Pilot and Flame Failure Option).
- Lighting the Griddles (If fitted).
- Oven Pilot Ignition.
- Oven Main Burner / Thermostat.
- Oven Fan.
- Turning Oven to 'Stand-By' Mode.
- Oven 'Shut-Down'.

Description of Controls



Gas Control Knobs

Griddle Option

Burner Control

- OFF Position
- ★ PILOT Burner
- △ HIGH Flame
- ▽ LOW Flame

Piezo Igniter (Griddle)
(Located here when fitted with Griddle Option)

Oven Thermostat

Temperature Graduations 50°C to 320°C

Oven Gas Control

- OFF Position
- ★ PILOT Burner
- △ HIGH Flame

Open Burner Option

- OFF Position
- △ HIGH Flame
- ▽ LOW Flame
- △ Rear Burner
- ▽ Front Burner

(Indicators located above the Gas Control Knobs).

Heating Indicator Lamp (Amber)

Power Indicator Lamp (White)

Piezo Igniter (Oven)

Open Burners ('F' - Flame Failure Option)

Lighting the Open Burners

Flame Failure Protection is incorporated for each burner by way of a thermo-electric system which will shut off gas supply to that burner in the event that burner goes out, so that un-burnt gas is not expelled.

- a. Select burner required, depress and turn the gas control knob anti-clockwise to 'HIGH' position.
- b. Hold gas control knob depressed and manually light main burner.
- c. Release gas control knob after approximately 10-20 seconds after lighting burner.
- d. Burner should stay alight - if not, repeat Steps (a. to (c. above.
- e. To adjust the temperature required, depress and rotate gas control knob between 'HIGH' and 'LOW' positions.

Turning 'OFF' the Open Burners

- a. When main burner is not required, depress and turn gas control knob clockwise back to 'OFF' position. 'MAIN' burner will extinguish.

Open Burners ('PF' - Pilot and Flame Failure Option)

Lighting the Open Burners

These hobs are fitted with individual standing pilots for each open burner which allows main burners to be turned 'ON' - 'OFF' without having to manually re-light burner each time that it is turned 'ON', as burner will automatically light itself off the pilot burner.

Flame Failure Protection is incorporated for each burner by way of a thermo-electric system which will shut off gas supply to that burner in the event that burner goes out, so that un-burnt gas is not expelled.

- a. Select burner required, depress and turn the gas control knob anti-clockwise to 'PILOT' position.
- b. Hold gas control knob depressed and manually light pilot burner.
- c. Release gas control knob after approximately 10-20 seconds after lighting pilot burner.
- d. Pilot burner should stay alight - if not, repeat Steps (b. to (c. above.
- e. To select 'Full Flame', depress and rotate gas control knob anti-clockwise to first stop 'HIGH' flame position.
- f. To select 'Low Flame', depress and rotate gas control knob fully anti-clockwise to 'LOW' flame position.
- g. To adjust the temperature required, depress and rotate gas control knob between 'HIGH' and 'LOW' positions.

Turning 'OFF' the Open Burners / Pilots

- a. To turn 'OFF' main burner, but keep pilot burner alight, rotate gas control knob to 'PILOT' position. Main burner will extinguish and pilot will remain alight.
- b. To turn 'OFF' the 'PILOT', depress and turn gas control knob clockwise back to 'OFF' position. 'PILOT' burner will extinguish.

Operation

Griddle

Lighting the Griddle

- a. Depress gas control knob and rotate anti-clockwise to 'PILOT' position.
- b. Hold gas control knob depressed, press piezo ignition button to ignite pilot burner. Repeat Items 1 to 2 until pilot is lit.
- c. Release gas control knob approximately 10-20 seconds after lighting pilot.
- d. Pilot should now remain alight - if not, repeat Steps (b. to (c. above).
- e. To select 'Full Flame', depress and rotate gas control knob anti-clockwise to 'HIGH' position.
- f. To select 'Low Flame', depress and rotate gas control knob fully anti-clockwise to 'Low Flame' position.
- g. When main burner is not required, depress and turn gas control knob clockwise back to 'OFF' position.

Turning 'OFF' the Griddle Burner / Pilot

- a. To turn 'OFF' griddle, but keep pilot burner alight, rotate gas control knob to 'PILOT' position. Griddle burner will extinguish and pilot will remain alight.
- b. To turn 'OFF' 'PILOT', depress and turn gas control knob clockwise back to 'OFF' position. 'PILOT' burner will extinguish.

Oven Pilot Ignition

! IMPORTANT

DO NOT USE aluminium foil or trays directly on cast iron sole plate(s). NEVER block or cover openings on each side of sole plate(s).

This oven is fitted with a pilot as a standard option and flame failure protection, which is incorporated by way of a thermo-electric system for the main burner. Flame failure protection will shut off gas supply to burner in the event that pilot burner goes out, so that un-burnt gas is not expelled. ***This is an important safety feature which is slowly becoming law throughout the world.***

1. Open oven door.
2. Depress oven gas control knob and rotate anti-clockwise to 'PILOT' position.
3. While holding oven gas control knob depressed, press piezo ignition button to ignite pilot burner. Repeat Items 1 and 2 until pilot burner is lit.
4. Release gas control knob approximately 10-20 seconds after lighting pilot.
5. Pilot should now remain alight - if not, repeat Steps 2 to 3 above.
6. Ensure that pilot burner is alight by opening pilot burner inspection covers and looking through pilot burner viewing holes in cast oven sole plate.

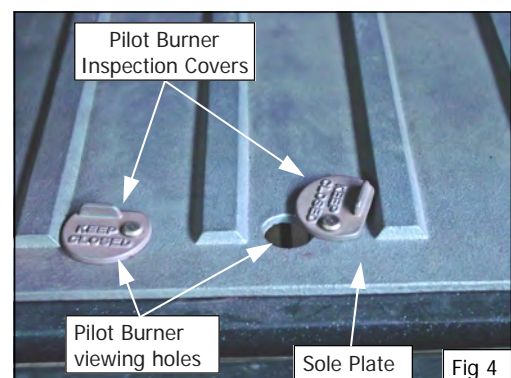

NOTE: Ensure that pilot burner inspection covers are closed once pilot is lit.

Oven - Main Burner / Thermostat

1. Ensure oven door is closed.
2. Turn 'ON' electrical power at mains supply, (white) power indicator light will illuminate on oven control panel.
3. With pilot burner alight, depress and rotate oven gas control knob to 'Main Flame' position. (This puts gas valve in 'Stand-By' position and control of main burner is now carried out through oven thermostat control).
4. Turn oven thermostat to desired oven temperature setting required, this will regulate gas supply to oven main burner.
5. Oven fan will start up and oven main burner will ignite.
6. Amber heating indicator light will show that oven main burner is 'ON' and oven is heating. When amber heating indicator light goes out, oven has reached pre-selected temperature, burner will cycle 'OFF'.

Oven Fan

1. Fan is operational only when oven thermostat is set to a temperature. Fan is controlled by a microswitch which in turn is controlled by opening and closing oven door. Oven fan is operational only with oven door closed.

Turning the Oven to 'Standby' (Pilot 'ON' Only)

1. To turn 'Off' oven main burner / heating, set oven thermostat to '0' temperature position, this will turn oven main burner 'OFF', but will leave oven pilot burner 'ON'.
2. In this position pilot burner will remain alight, but oven main burner will not operate until thermostat control knob is set to a temperature.
3. If oven pre-heating is required, set thermostat control knob to temperature 190°C and allow 20 minutes before cooking in oven to allow oven to warm up.

Oven 'Shut-Down'

1. To 'Shut Down' oven, turn oven thermostat to '0' position, oven main burners will go out.
2. Turn gas control valve to 'OFF' position and this will extinguish pilot burner. (To relight pilot burner, refer to 'Oven Pilot Ignition' above).
3. Turn 'OFF' electrical power at mains supply, (white) power indicator light will extinguish.

NOTE: If main burner has recently been turned 'OFF', should you wish to re-light oven, the interlock will not allow gas valve to be turned to main burner position until interlock has reset (Approximately 1 minute). DO NOT FORCE GAS VALVE TO MAIN BURNER POSITION UNTIL INTERLOCK HAS RESET, as this will damage gas control valve.

IMPORTANT:

Should any abnormal operation like;

- ignition problems,
 - abnormal burner flame,
 - burner control problems,
 - partial or full loss of burner flame in normal operation, appliance requires **IMMEDIATE** service by a qualified service person and should not be used until a service is carried out.
-

Cleaning and Maintenance

Before Commencing Cleaning



Always turn off the gas / electrical supply before cleaning the appliance.

This appliance is not water proof. Do not use water jet spray to clean interior or exterior of this appliance.

NOTE:

- Allow appliance to cool before commencing cleaning.
- DO NOT use abrasive or strong caustic detergents as they could corrode or damage the Cooktop.
- Ensure that any detergent or cleaning material has been completely removed after each cleaning.

To keep your Cooktop clean and operating at peak efficiency, follow the procedures shown overleaf:-

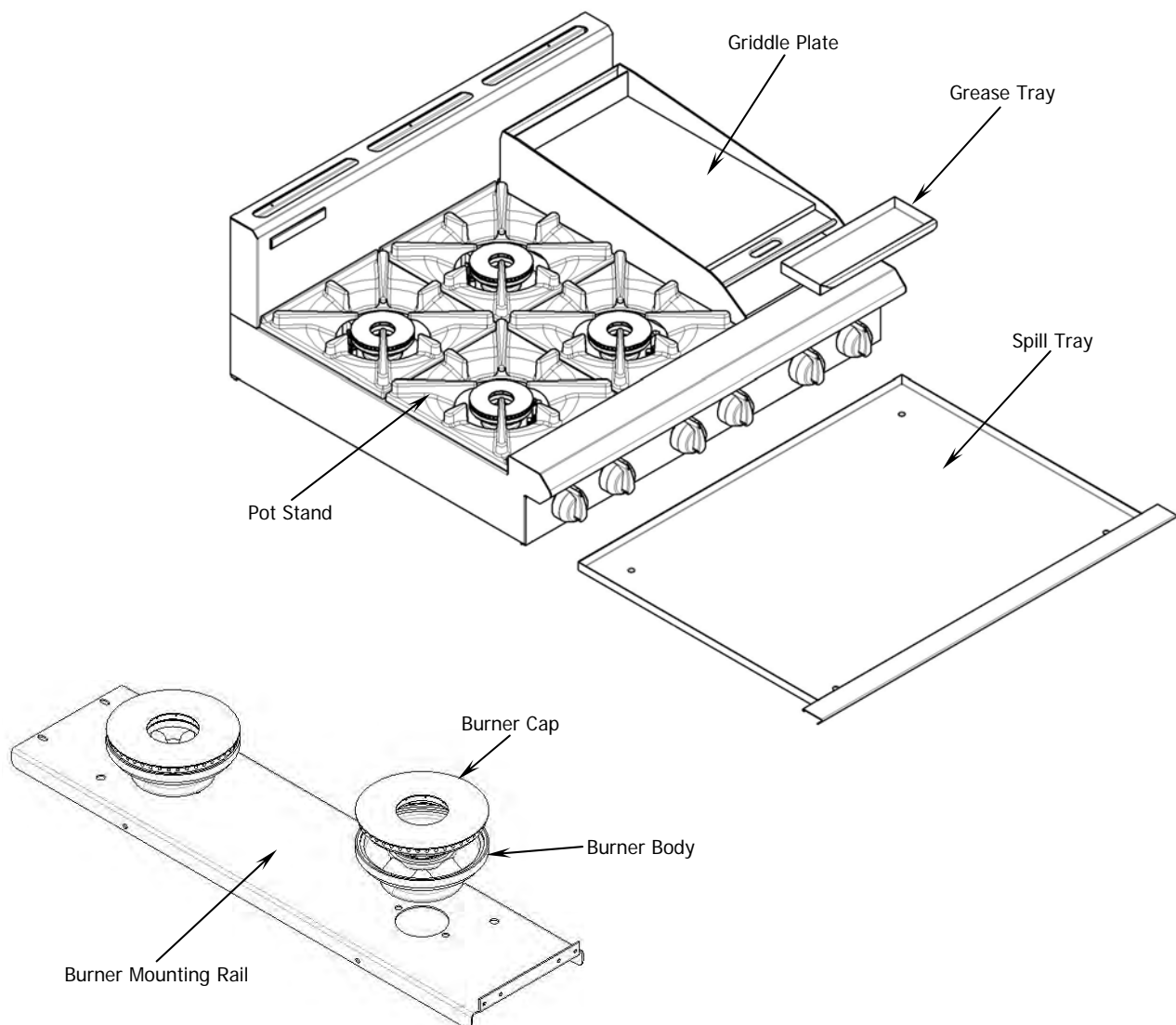

Open Burner Cleaning

1. Remove pot stands, burner caps, burner bowls and pot stand supports from top of cooktop. Wash with hot soapy water, using a soft bristled brush. Dry thoroughly with a dry cloth. Any baked-on deposits can be scraped off using a scraper tool.

NOTE: Pot stands, burner bowls and pot stand supports can be washed in a dish washer. Do Not wash burner caps in dishwasher.

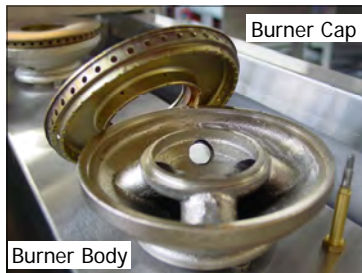

2. Burner mounting rails should not be removed. Clean in situ with hot soapy water.

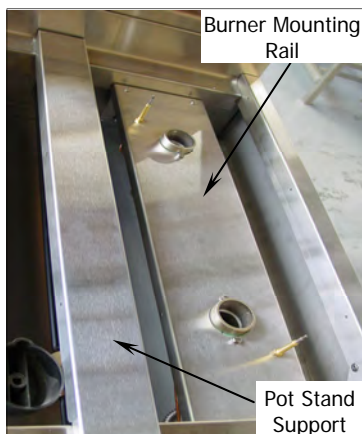

3. Clean burner venturi with a bottle brush and hot soapy water, as required.

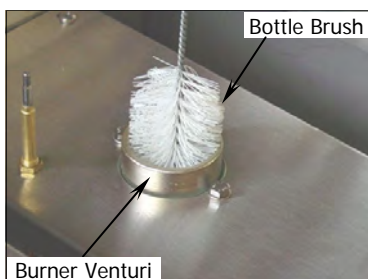

4. Empty spill tray and wash with warm soapy water.
5. Dry all components thoroughly and re-assemble.

Griddle Plate Cleaning

It is recommended that a flat blade scraper is used to clean the griddle surface, these are not supplied with griddle but may be purchased separately. Refer to 'Replacement Parts List' at rear of this manual.



Warning

THE BLADES FITTED TO THE SCRAPER TOOL ARE EXTREMELY SHARP AND ARE TO BE USED WITH CARE.



Caution

Always ensure that even pressure is applied over whole surface of scraper tool when using on flat surface of griddle, to prevent scoring of griddle surface.

NEVER bang sharp edge of scraper tool on flat surface of griddle as this will damage the griddle and invalidate the warranty.



1. Clean griddle plate surface thoroughly with a scraper tool and brush off any deposits with a soft bristled brush.
2. Stubborn or accumulated carbon deposits can be removed with a griddle stone or a scotch bright pad.
3. Wipe down griddle surface with a cloth and then clean with hot soapy water and a soft bristled brush. Dry thoroughly with a dry cloth.
4. Occasionally bleach griddle plate with vinegar when plate is cold.
5. Empty grease tray and wash with warm soapy water. Dry thoroughly with a dry cloth. Refit grease tray.
6. Briefly turn 'On' griddle until griddle plate is dry.
7. Spread a thin smear of cooking oil over griddle plate to form a protective film.

Cleaning and Maintenance

Oven Interior Cleaning

1. Do not use wire brushes, steel wool or other abrasive materials to clean oven interior.
2. Clean oven regularly with a good quality domestic oven cleaner.
3. Weekly - Remove and clean any built up of grease etc. from oven racks and bottom spill cover.
4. Dry oven thoroughly with a dry cloth and polish with a soft dry cloth.

Stainless Steel Surfaces

1. Clean stainless steel surfaces with hot soapy water and a soft bristled brush.
2. Baked on deposits or discolouration, use a good quality stainless steel cleaner or stainless steel wool. Always rub in direction of grain.

This section provides an easy reference guide to more common problems that may occur during operation of your appliance. The fault finding guide in this section is intended to help you correct, or at least accurately diagnose problems with your equipment.

Although this section covers most common problems reported, you may encounter a problem not covered in this section. In such instances, please contact your local authorised service agent who will make every effort to help you identify and resolve the problem. Please note that the service agent will require the following information:-

- **Model Code and Serial Number of appliance. (Both can be found on the Rating Plate located on the appliance).**

Fault	Possible Cause	Remedy
Pilot won't light.	No gas supply.	Ensure gas isolation valve is turned on, and bottles are not empty.
	Blocked pilot injector.	Call service provider.
Pilot goes out when gas control knob released.	Releasing knob before thermocouple has heated.	Hold knob in for at least 20 seconds following ignition of pilot.
	Pilot flame too small. - Gas pressure too low. - Partially blocked pilot injector.	Clean or replace pilot injector.
	Thermocouple connection to gas control is loose or faulty.	Tighten thermocouple connection.
	Thermocouple faulty.	Check thermo couple is producing between 20-30mV.
	Electromagnet in rear of gas control unit is faulty.	Inspect and replace if not in good working order. Call service provider.
Main burner will not light.	Incorrect supply pressure.	Call service provider.
	Faulty gas control.	Call service provider.
Piezo Ignition spark is being generated but not sparking from ignition electrode to pilot burner hood. (On Griddle and Oven Options).	HT lead damaged or broken.	Repair or replace the HT lead.
	Check ignition electrode is not cracked and is correctly positioned.	Re-position or replace ignition electrode.
	Piezo igniter faulty.	Replace piezo igniter. Call service provider.

NOTE: Components having adjustments protected (e.g. paint sealed) by the manufacturer, are only to be adjusted by an authorised service agent. They are not to be adjusted by an unauthorised service person.

Wiring Schematic

G54 / G56 / G58

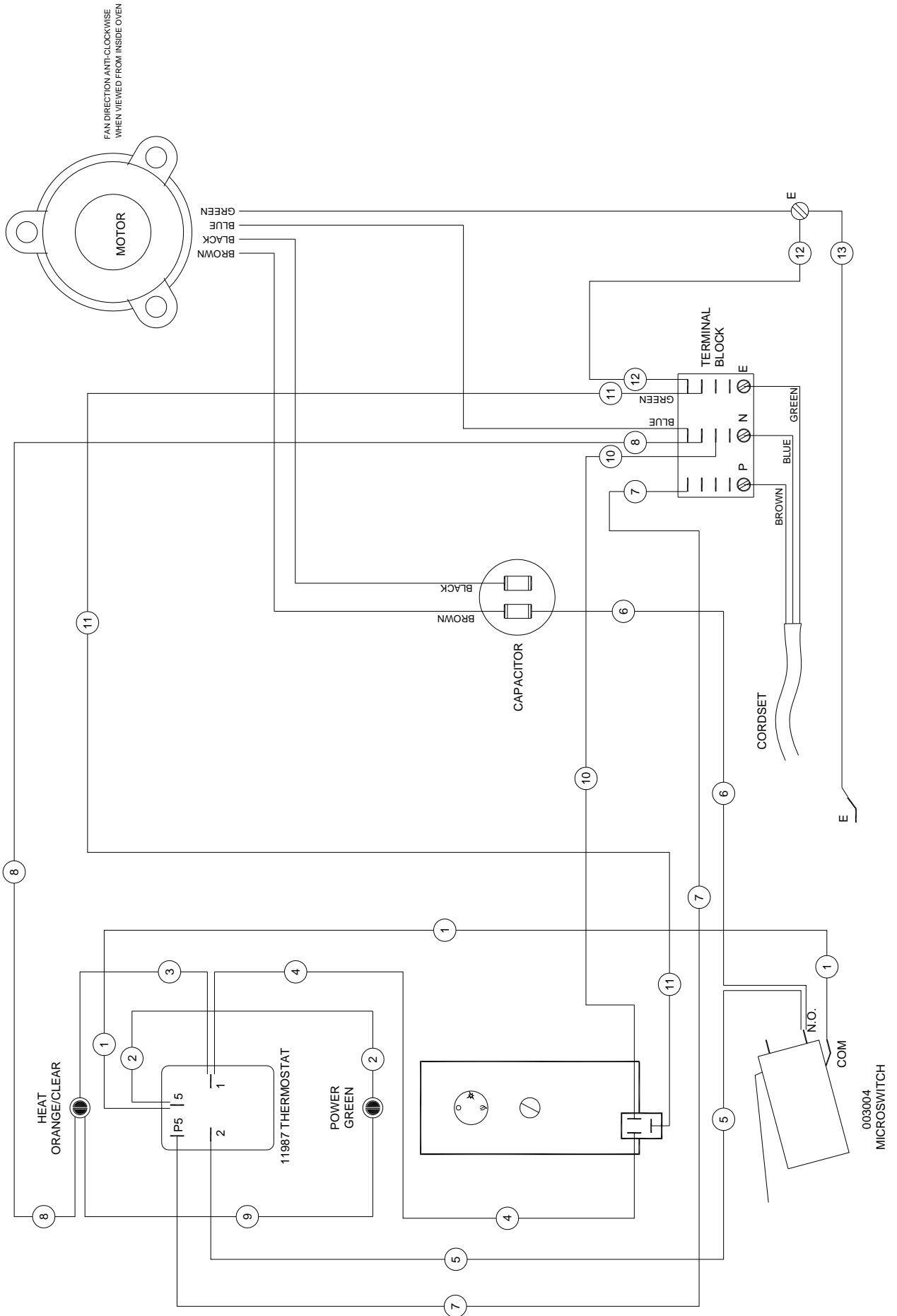

Conversion Procedure



Caution

Ensure that the Appliance is isolated from the gas supply before commencing servicing.

NOTE:

- These conversions should only be carried out by qualified persons. All connections must be checked for leaks before re-commissioning the appliance.
- Adjustment of components that have adjustments / settings sealed (e.g. paint sealed) can only be adjusted in accordance with the following instructions and shall be re-sealed before re-commissioning this appliance.
- For relevant gas specifications refer to 'Gas Specifications Tables' at end of this section.

Open Burners.

1. Remove the pot stands, burner caps and burner bodies and the pot stand supports.
2. Remove injectors and replace with correct size injectors as shown in 'Gas Specifications Tables' at end of this section.

For F Options Only,

Unscrew and remove Main Injectors.

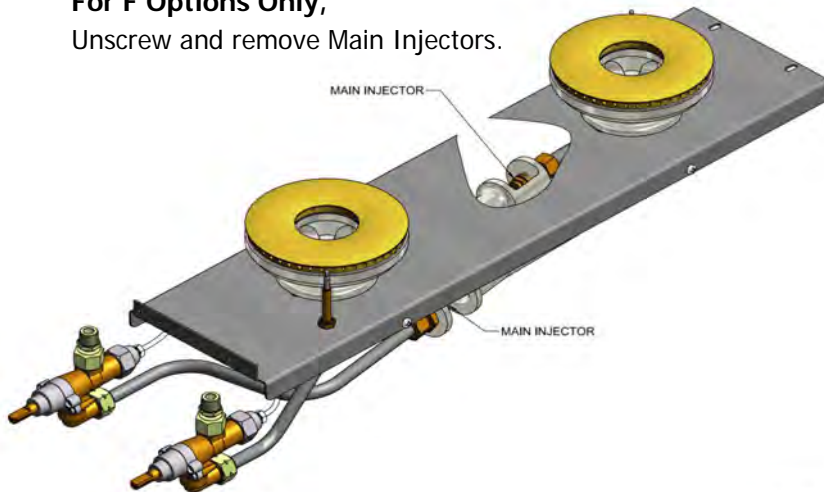

For PF Options Only,

Unscrew and remove Main and Pilot Injectors.

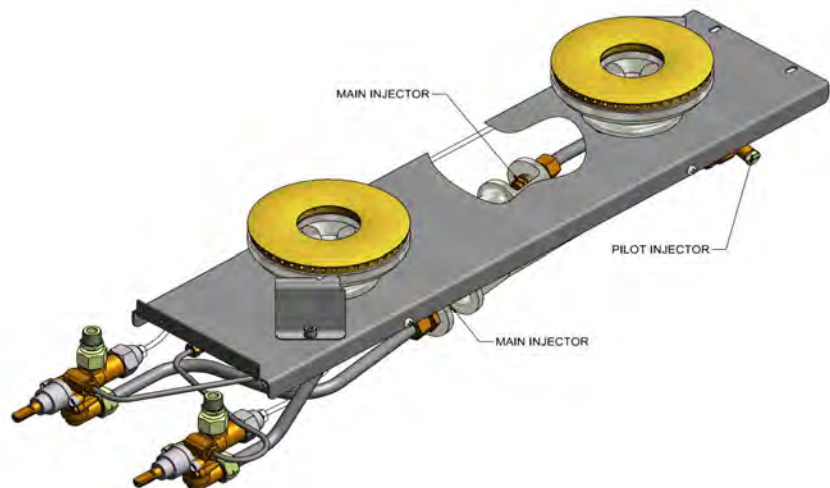

3. Refit the pot stand supports, pot stands, burner caps and burner bodies.
4. Re-light main burners and check flame size on simmer (LOW) position.
 - Adjust low fire adjustment screw on open burner gas control valves to obtain desired flame size.

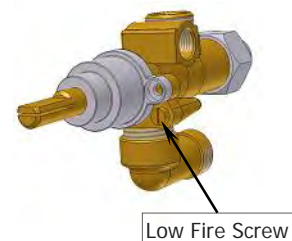

NOTE: The 'Low Fire Screw' should be sealed with coloured paint on completion of low fire adjustment.

Gas Conversion and Specifications

Griddle

1. Carry out the following:-
 - Remove griddle plate section and heat shield.
 - Remove main burner.
 - Disconnect piezo igniter from mounting bracket. (For access purposes).
 - Disconnect pilot supply tube from pilot burner to access pilot injector.

2. With Main Burner removed, ensure aeration gap is adjusted for type of gas being used as shown in 'Gas Specifications Tables' at rear of this section.

3. Remove pilot and main injectors and replace with correct size injectors as shown in 'Gas Specifications Tables' at rear of this section.

4. Refit the following:-
 - Re-connect pilot supply tube to pilot burner.
 - Re-connect piezo igniter to mounting bracket.
 - Refit main burner, gas control heat shield and griddle plate to cooktop.

5. Re-light main burners and check flame size on 'Low' flame position.
 - **Adjust low fire adjustment screw on open burner gas control valves to obtain desired flame size.**

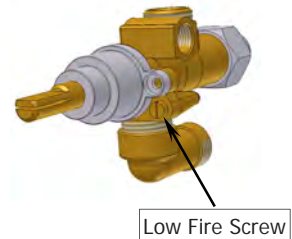
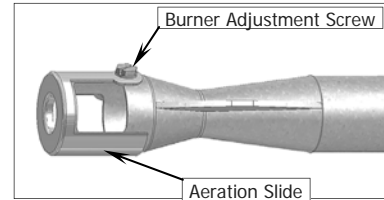
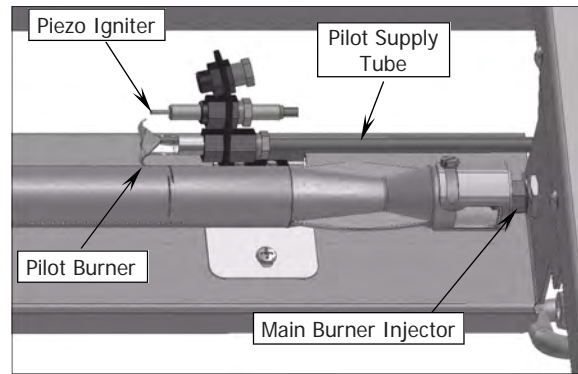

NOTE: The 'Low Fire Screw' should be sealed with coloured paint on completion of low fire adjustment.

Convection Oven

1. Carry out the following:-
 - Remove lower lintel at front of oven.
 - Open oven door and remove sole plate(s).
 - Loosen clamp bracket and remove main burner.
 - Remove thermocouple and piezo igniter from mounting bracket. (For access purposes).
 - Disconnect pilot supply tube from pilot burner to access pilot injector.

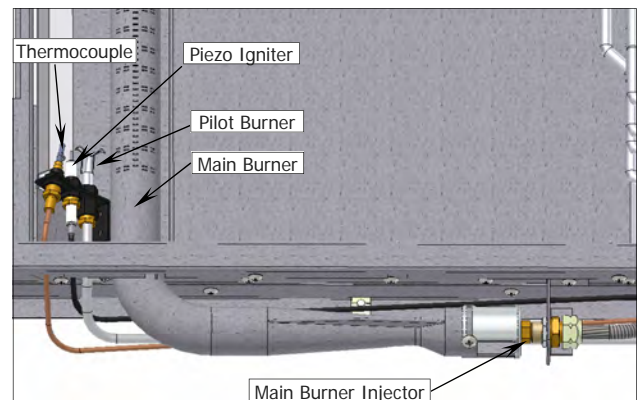

2. With Main Burner removed, ensure aeration gap is adjusted for type of gas being used as shown in 'Gas Specifications Tables' at end of this section.

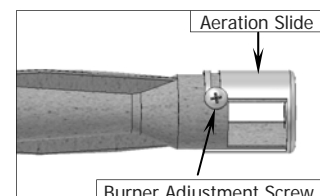

Gas Conversion and Specifications

3. Remove pilot and main injectors and replace with correct size injectors as shown in 'Gas Specifications Tables' at end of this section.
4. Refit the following:-
 - Re-connect pilot supply tube to pilot burner.
 - Re-connect piezo igniter and thermocouple to mounting bracket.
 - Refit main burner and secure clamp bracket.
 - Refit sole plate(s) and lower lintel.

NOTE: There is no 'Low Fire' adjustment on the gas control valve for the GC Oven.

- Refit the oven control panel.

Gas Regulator

NOTE: Gas regulator supplied is convertible between Natural Gas and LP Gas, but it's outlet pressure is fixed ex-factory and is NOT to be adjusted.

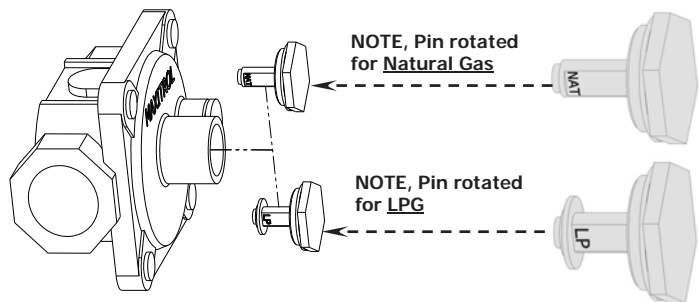

- Town Gas Only.

1. Remove slotted cap from regulator.
2. Turn 'On' gas supply and appliance.
3. Adjust pressure adjusting screw to achieve correct burner operating pressure.

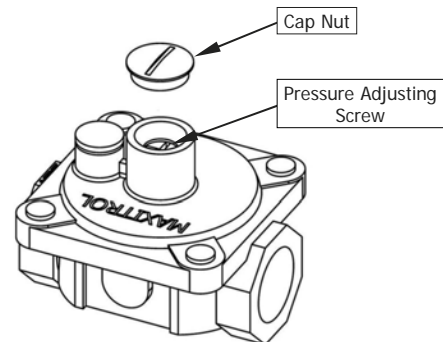

NOTE: Measure operating pressure at manifold test point with two burners operating at 'High Flame' setting.

4. Verify operating pressure remains correct (Re-adjust regulator if required).
5. Screw cap nut back onto regulator.

Gas Type Identification Label

On completion of gas conversion, replace gas type identification label located at:-

- Rear of appliance, above gas connection.
- Beside the rating plate.

Commissioning

Before leaving the installation;

1. Check all gas connections for leakage using soapy water or other gas detecting equipment.



Warning



DO NOT USE A NAKED FLAME TO CHECK FOR GAS LEAKAGES.

2. Carry out a 'Commissioning' check of appliance as shown in Installation Section of this manual.
3. Ensure any adjustments done to components that have adjustments / settings paint sealed are to be re-sealed.



Gas Conversion and Specifications

Gas Specifications

- Australia:

		Natural Gas	LP Gas (Propane)
Open Burner	Main Burner Injectors	Ø 2.45mm	Ø 1.50mm
	Pilot Burner ('PF' Option Only)	0.30	0.20
Griddle	Main Burner	Ø 2.10mm	Ø 1.30mm
	Pilot Burner	0.35	0.23
	Burner Aeration Setting	Fully Open	Fully Open
Oven	Main Burner	Ø 2.60mm	Ø 1.60mm
	Pilot Burner	0.35	0.23
	Burner Aeration Setting	Fully Open	Fully Open
Supply Pressure		1.13 - 3.40 kPa	2.75 - 4.50 kPa
Burner Operating Pressure (*)		0.95 kPa	2.6 kPa
Gas Regulator Cap Screw			

- New Zealand):



		Natural Gas	LP Gas
Open Burner	Main Burner Injectors	Ø 2.45mm	Ø 1.50mm
	Pilot Burner ('PF' Option Only)	0.30	0.20
Griddle	Main Burner	Ø 2.10mm	Ø 1.30mm
	Pilot Burner	0.35	0.23
	Burner Aeration Setting	Fully Open	Fully Open
Oven	Main Burner	Ø 2.60mm	Ø 1.60mm
	Pilot Burner	0.35	0.23
	Burner Aeration Setting	Fully Open	Fully Open
Supply Pressure		1.13 - 3.40 kPa	2.75 - 4.50 kPa
Burner Operating Pressure (*)		0.95 kPa	2.6 kPa
Gas Regulator Cap Screw			

- (*) Measure burner operating pressure at manifold test point with two burners operating at full setting. Operating pressure is ex-factory set, through the appliance regulator and is not to be adjusted, apart from when carrying out Gas Conversion, if required. (Refer to information in this section for details).

Gas Conversion and Specifications

- UK Only:

Category: I_{2H3P} (20, 37).
 Flue Type: A₁.

		Natural Gas (G20)	Propane (G31)
Open Burner	Main Burner Injectors	Ø 2.30mm	Ø 1.40mm
	Pilot Burner ('PF' Option Only)	0.30	0.20
Griddle	Main Burner	Ø 2.10mm	Ø 1.30mm
	Pilot Burner	0.35	0.23
	Burner Aeration Setting	Fully Open	Fully Open
Oven	Main Burner	Ø 2.60mm	Ø 1.60mm
	Pilot Burner	0.35	0.23
	Burner Aeration Setting	Fully Open	Fully Open
Supply Pressure		20 mbar	37 mbar
Burner Operating Pressure (*)		9.5 mbar	26 mbar
Gas Regulator Cap Screw			

- (*) Measure burner operating pressure at manifold test point with two burners operating at full setting. Operating pressure is ex-factory set, through the appliance regulator and is not to be adjusted, apart from when carrying out Gas Conversion, if required. (Refer to information in this section for details).

Gas Conversion and Specifications

- All Other Markets:

		Natural Gas	Town Gas (**)
Open Burner	Main Burner	Ø 2.45mm	Ø 4.50mm
	Pilot Burner ('PF' Option Only)	0.30	0.60
Griddle	Main Burner	Ø 2.10mm	Ø 3.40mm
	Pilot Burner	0.35	0.60
	Burner Aeration Setting	Fully open	Fully open
Oven	Main Burner	Ø 2.6mm	Ø 5.0mm
	Pilot Burner	0.35	0.60
	Burner Aeration Setting	Fully Open	Fully Open
Supply Pressure		1.13 - 3-4 kPa	0.75 - 1.50 kPa
Burner Operating Pressure (*)		0.95 kPa	0.63 kPa
Gas Regulator Cap Screw			Adjustable Regulator (Adjust to Burner Operating Pressure specified).

		LP Gas (Propane)	Butane
Open Burner	Main Burner	Ø 1.50mm	Ø 1.40mm
	Pilot Burner ('PF' Option Only)	0.20	0.20
Griddle	Main Burner	Ø 1.30mm	Ø 1.20mm
	Pilot Burner	0.23	0.23
	Burner Aeration Setting	Fully open	
Oven	Main Burner	Ø 1.60mm	Ø 1.45mm
	Pilot Burner	0.23	
	Burner Aeration Setting	Fully Open	
Supply Pressure		2.75 - 4.50 kPa	
Burner Operating Pressure (*)		2.6 kPa	
Gas Regulator Cap Screw			

NOTE:

- (*) Measure Burner operating pressure at manifold test point with two burners operating at 'High Flame' setting.
- NAT, LPG & Butane Only - Operating pressure is ex-factory set and is not to be adjusted, unless when converting between gases, if required.
- (**) TOWN GAS Only - Adjust burner operating pressure using adjustable gas regulator supplied.

Replacement Parts List

IMPORTANT:

Only genuine authorized replacement parts should be used for servicing and repair of this appliance. Instructions supplied with parts should be followed when replacing components.

For further information and servicing instructions, contact your nearest authorized service branch (contact details are as shown on reverse of front cover of this manual).

When ordering replacement parts, please quote part number and description as listed below. If part required is not listed below, request part by description and quote model number and serial number which is shown on rating plate.

Cooktop

Open Burners

235678	Burner Body.			
227017	Burner Cap.			
030245	Injector	(Nat. Gas)	Ø 2.45mm.	
030230	Injector	(Natural Gas - G20)	Ø 2.30mm	(UK Only).
030150	Injector	(LP Gas / Propane)	Ø 1.50mm.	
030140	Injector	(LP Gas / Butane)	Ø 1.40mm.	
030450	Injector	(Town Gas)	Ø 4.50mm.	
026134	Pilot Injector	(Nat Gas)	0.30.	
026136	Pilot Injector	(LP Gas / Butane)	0.20.	
232309	Pilot Injector	(Town Gas)	0.60.	
229442	Pilot Bracket Assembly.			
229444	Pilot Burner Shield.			
227379	Knob - Open Burner	(Standard).		
227378	Knob - Open Burner	(with Pilot).		
227403	Gas Control	(with Pilot and Flame Failure).		
227405	Gas Control	(With Flame Failure).		
228167	Thermocouple - Front.			
228166	Thermocouple - Rear.			

Griddle

014105	Burner.			
032210	Burner Injector	(Nat. Gas)	Ø 2.10mm.	
032130	Burner Injector	(LP Gas)	Ø 1.30mm.	
032120	Burner Injector	(Butane)	Ø 1.20mm	
032340	Burner Injector	(Town Gas)	Ø 3.40mm.	
026488	Pilot Injector	(Nat. Gas)	0.35.	
019217	Pilot Injector	(LP Gas / Butane)	0.23.	
018067	Pilot Injector	(Town Gas)	0.60.	
227403	Gas Control	(with Flame Failure and Pilot).		
227378	Knob - Griddle.			
019215	Pilot Burner.			
019428	Thermocouple.			
227508	Piezo Ignitor.			
228047	Piezo H.T. Lead.			
018744	Piezo Ignition Electrode.			
228288	Grease Tray	(Griddle Plates).		

Replacement Parts

Oven

232234	Knob Thermostat 80-300°.		
227933	Oven Burner.		
018691K	Oven Pilot.		
020253	Oven Thermocouple.		
018743	Thermocouple Spacer.		
032260	Burner Injector	(Nat Gas)	Ø 2.60mm.
032160	Burner Injector	(LPG)	Ø 1.60mm.
032145	Burner Injector	(Butane)	Ø 1.45mm.
032500	Burner Injector	(Towns Gas)	Ø 5.00mm.
026488	Pilot Injector	(Nat. Gas)	0.35.
019217	Pilot Injector	(LPG / Butane)	0.23.
018067	Pilot Injector	(Town Gas)	0.60.
011987	Thermostat.		
020103	Gas Control.		
227508	Piezo Ignitor.		
019407	H.T Lead.		
019479K	Motor Kit.		
010866	Cooling Disc.		
228116	Fan 200 x 40mm.		
010909	Motor Capacitor 4µf.		
026160	Terminal Block - Mains.		
228704	Door Spring Kit.		
227963	Indicator Neon Amber.		
228922	Indicator Neon White.		
228938	Door Microswitch.		
230268	Pilot Viewing Hole Lid.		
748001	Taptite Screw M5 x 16.		
044018	Nut M5 Glenloch Locknut.		

General

227014	Pot Stand.		
230282	Spill Tray - 750mm	(G54 Series).	
230273	Spill Tray - 450mm	(G56 Series).	
230277	Spill Tray - 600mm	(G58 Series).	
227892	Side Rack LH.		
227893	Side Rack RH.		
023068	Side Rack Screw.		
232350	Baffle.		
227896	Oven Rack	(G56 / (G58 Series).	
228106	Oven Rack	(G54 Series).	
227850	Adjustable Leg - 150mm.		
229674	Rear Roller Assy.		

Accessories

228566	Griddle Scraper Tool.		
228567	Smooth Plate Scraper Blades (Pack of 5 Blades).		
228568	Ribbed Plate Scraper Blade (Individual Blade).		
228797	750mm Plinth Kit.		
228800	900mm Plinth Kit.		
228804	1200mm Plinth Kit.		

Gas Regulators

Gas Type	Gas Regulators	
	Part No.	Description
Nat. Gas LPG Butane	228531	¾" BSP F/F Convertible.
Town Gas	230185	¾" BSP F/F Adjustable.

Gas Conversion Kits

Models		Gas Type to Convert to					
		Nat. Gas	LPG	Butane	Town Gas	Nat. Gas (UK)	Propane (UK)
'F' Models	G54	231885	231884	231886	231887	231909	231908
	G56	231889	231888	231890	231891	231911	231910
	G58	231893	231892	231894	231895	231913	231912
'PF' Models	G54	231897	231896	231898	231899	231915	231914
	G56	231901	231900	231902	231903	231917	231916
	G58	231905	231904	231906	231907	231919	231918

NOTE: Each gas conversion kit is universal for all hob open burners and griddle variations possible within the model specified.

