

ELECTRIC GRIDDLE 600mm

EP514-B, EP514-CB, EP514-LS

- Heavy-duty thermostatic electric griddle
- 20mm thick griddle plate
- Ribbed plate options
- Mirror chromed plate options
- Top weld sealed plates
- 7.2kW heating elements
- 2 models of base unit
- Rear rollers
- Stainless steel exterior
- Easy clean
- Easy service
- Fully modular



EP514-LS

Overall Construction

Griddle

- 20mm thick machined top plates standard
- Optional ribbed plate sections
- Optional mirror finish hard chrome plates
- 2.5mm thick stainless steel splash guards sides and rear
- 2.5mm thick grease channel
- Single temperature control zone
- Welded hob surround with 1.5mm stainless steel bull nose
- Side panels 1.2mm stainless steel
- Splashback 1.2mm stainless steel
- Enamelled control panel
- Stainless steel grease drawer
- Overlapping finish at front and rear of plate for easy clean

Bench mount (supplied as -B model)

- Four 63mm dia. heavy-duty 1.2mm stainless steel bench legs with adjustable feet
- Adjustable height 80mm - 105mm

Cabinet base (supplied as -CB model)

- Fully modular for match suite finish
- Double skin 0.9mm stainless steel interior and exterior
- Optional GN 1/1 4 position racking kit
- 63mm dia. heavy-duty 1.2mm stainless steel legs with two adjustable feet at front and two rollers at rear

Leg stand (supplied as -LS model)

- Fully modular for matched suite finish
- Framed top for connection to Griddle
- 63mm dia. heavy-duty 1.2mm stainless steel legs with two adjustable feet at front and two rollers at rear
- Fully modular framed stand shelf with 0.9mm stainless steel finish
- Quick assembly design

Controls

- 50-300°C thermostat
- Single temperature control zone
- Large easy use control knob - heat resistant reinforced
- Easy view control settings on knob
- Indicator lights for power and heating
- Over-temperature safety cut-out

Cleaning and Servicing

- All models with easy clean stainless steel external finish
- Plate is finished front and rear with overlap construction to remove cleaning traps
- Control service through front of unit

ELECTRIC GRIDDLE 600mm

EP514-B, EP514-CB, EP514-LS

Specifications

Elements

3 x 2.4kw stainless steel sheathed heating elements

Electrical requirements

7.2kW
230-240Vac, 50/60Hz, 1P+N+E, 30A

Plate

Cooking surface 592mm x 530mm, 3138cm²

Dimensions

Bench models

Width 600mm
Depth 812mm
Height 315mm
Incl. splashback 485mm

All models (excluding Bench model)

Width 600mm
Depth 812mm
Height 915mm
Incl. splashback 1085mm

Nett weight

Bench and Leg Stand models

118kg

Cabinet Base models

120kg

Packing data

Bench and Leg Stand models

0.37m³, 170kg
Width 645mm
Depth 870mm
Height 665mm

Cabinet Base models

0.70m³, 172kg
Width 645mm
Depth 870mm
Height 1255mm

Options

Adjustable feet at rear
Joining caps
Castors
Ribbed plate options
Mirror chromed plate options

EP514-B

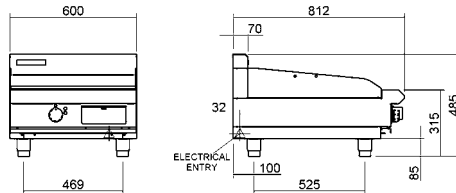

EP514-LS

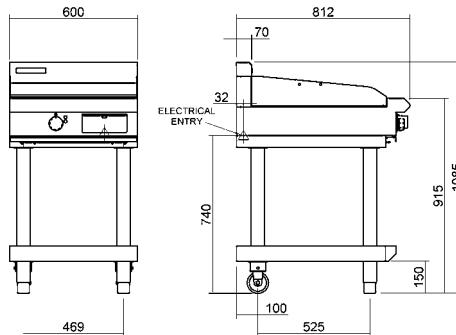

EP514-CB

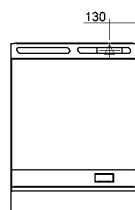
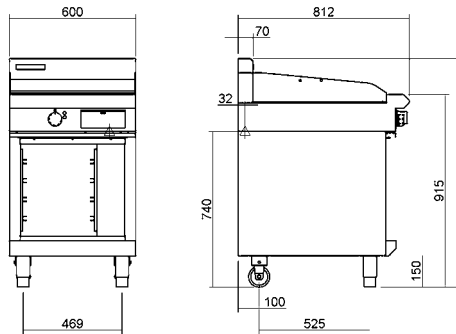

moffat.com.au
moffat.co.nz

Australia
moffat.com.au

Moffat Pty Limited

Victoria/Tasmania
740 Springvale Road
Mulgrave, Victoria 3170
Telephone +613-9518 3888
Facsimile +613-9518 3833
vsales@moffat.com.au

New South Wales
Telephone +612-8833 4111
nswsales@moffat.com.au
South Australia
Telephone +613-9518 3888
vsales@moffat.com.au

Queensland
Telephone +617-3630 8600
qldsales@moffat.com.au

Western Australia
Telephone +618-9413 2400
wasales@moffat.com.au

New Zealand

moffat.co.nz

Moffat Limited

Rolleston
45 Illinois Drive
Izone Business Hub
Rolleston 7675
Telephone +64 3-983 6600
Facsimile +64 3-983 6660
sales@moffat.co.nz

Auckland
Telephone +64 9-574 3150
sales@moffat.co.nz



In line with policy to continually develop and improve its products, Moffat Limited reserves the right to change specifications and design without notice.

© Copyright Moffat Ltd
AN.BSE.01.19/1620

an Ali Group Company



The Spirit of Excellence