



**CO
OK
MA
TIC**

New Cookmatic

**Dai nuova forma alla perfezione.
Give perfection a new shape.**

Cookmatic è pensata per la produzione di basi, di tartellette e di pastafrolla dolce e salata. Un sistema semplice che permette di realizzare differenti forme e misure in poco tempo, grazie alle piastre intercambiabili. Tramite l'accoppiamento delle due piastre puoi ottenere tartellette perfette per dimensione e cottura. La nuova interfaccia permette una programmazione più intuitiva e rapida. Cookmatic è facile da pulire ed è adatta alla produzione in continuo per diverse ore. **2 anni di garanzia.**

Cookmatic is designed for the production of bases, tartlets and both sweet and savoury pastries. Thanks to the interchangeable plates, you will be able to make different shapes and sizes quickly. The combination of the two plates ensures the production of perfectly cooked and shaped tartlets. The new interface allows for faster and more intuitive programming. Cookmatic is easy to clean and suitable for continuous production over several hours. **2 year warranty.**

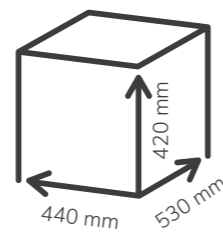

Dimensioni macchina chiusa
Closed machine dimensions

CODE	PESO WEIGHT (kg)	POTENZA ELETTRICA ELECTRICAL POWER (Watt)	TENSIONE ELETTRICA ELECTRICAL VOLTAGE (Volt)
NEWCOOKMATICPAV	28	3200	220/240 *110/380

* a richiesta
on demand



Guarda il video dedicato a **Cookmatic** sul canale Youtube di Pavoni Italia
Watch the video "**Cookmatic**" on Pavoni Italia's Youtube channel

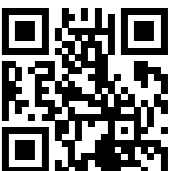

Piastre per tartlet Cookmatic

Tartlet plates for Cookmatic

Utilizzabili anche su Cookmatic Special - pag. 28

They can be use also with Cookmatic Special - pag. 28

La tua libertà creativa è garantita da un'ampia selezione di forme realizzabili. Cookmatic monta due piastre di cottura: una superiore e una inferiore. Scegli tra le coppie di piastre disponibili - realizzate in materiale antiaderente - a seconda del tipo di tartelletta che desideri e cambiale in libertà con pochi semplici gesti.

A wide selection of possible shapes guarantees your creative freedom. Cookmatic is provided with two cooking plates: an upper and a lower. All are made of non-stick material. Choose from the pairs of plates available for the type of tartlet you want. You can change them out whenever you want in just a few simple steps.

Peso piastra - Plate weight kg 11 (variabile a seconda della piastra - variable depending on the plate)

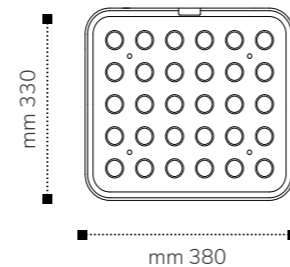

Eclair	CODE	DIMENSIONI DIMENSIONS (mm)	SPESSORE THICKNESS (mm)
	PIASTRA 39	66x27 64x25 15	pareti - borders 3,5 fondo - bottom 3,5
	PIASTRA 38	126x32 123x30 15	pareti - borders 3,5 fondo - bottom 3,5
Tonde - Rounded	CODE	DIMENSIONI DIMENSIONS (mm)	SPESSORE THICKNESS (mm)
	PIASTRA 9	ø 33 ø 28 20	pareti - borders 3 fondo - bottom 4

CODE	DIMENSIONI DIMENSIONS (mm)	SPESSORE THICKNESS (mm)
 PIASTRA 15	ø 35 25 ø 32	pareti - borders 3,5 fondo - bottom 4,5
 PIASTRA D	ø 40 16 ø 26	pareti - borders 3 fondo - bottom 5,5
 PIASTRA 2	ø 40 18 ø 26	pareti - borders 3,5 fondo - bottom 3,5
 PIASTRA 52	ø 41 15 ø 36	pareti - borders 3,5 fondo - bottom 4
 PIASTRA 46	ø 42 18 ø 35	pareti - borders 3,5 fondo - bottom 4
 PIASTRA 42	ø 43 17 ø 31	pareti - borders 3,5 fondo - bottom 3,5
 PIASTRA 0	ø 46 20 ø 30	pareti - borders 4 fondo - bottom 4
 PIASTRA 26	ø 48 18 ø 41	pareti - borders 4 fondo - bottom 3,5

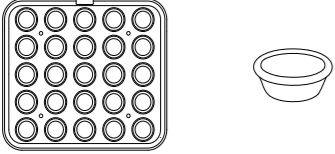
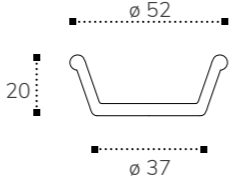
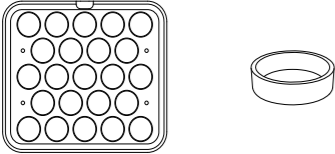
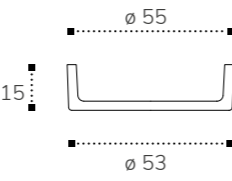
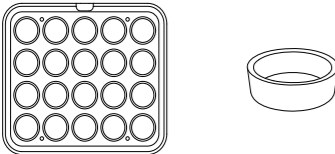
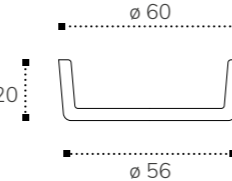
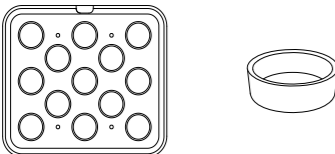
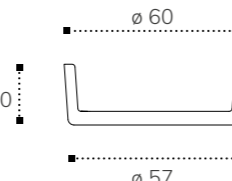
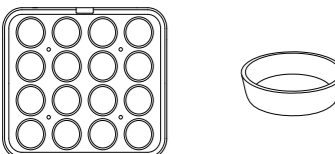
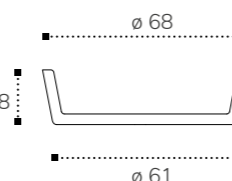
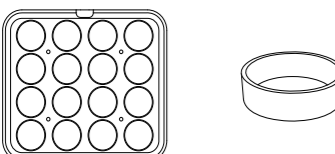
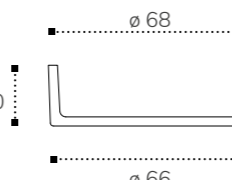
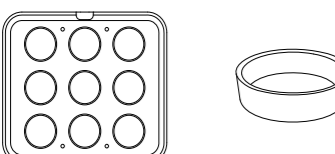
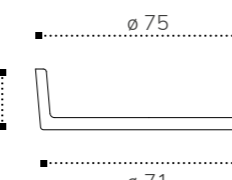
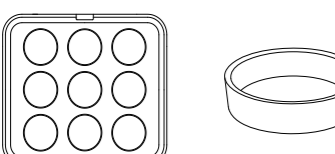
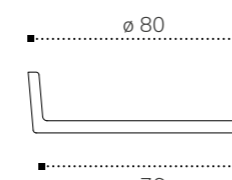
	CODE	DIMENSIONI DIMENSIONS (mm)	SPESSORE THICKNESS (mm)
	PIASTRA 12		pareti - borders 3,5 fondo - bottom 4
	PIASTRA 57		pareti - borders 3 fondo - bottom 3
	PIASTRA 21		pareti - borders 4 fondo - bottom 4
	PIASTRA 24		pareti - borders 3,5 fondo - bottom 4,5
	PIASTRA 13		pareti - borders 3,5 fondo - bottom 3,5
	PIASTRA 56		pareti - borders 3 fondo - bottom 3
	PIASTRA 29		pareti - borders 3,5 fondo - bottom 4
	PIASTRA W		pareti - borders 3,5 fondo - bottom 4

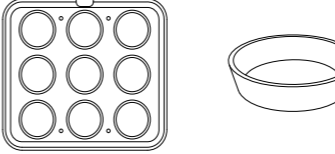
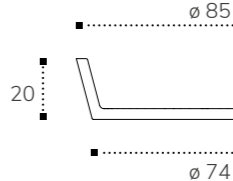
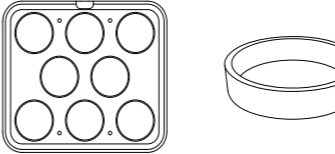
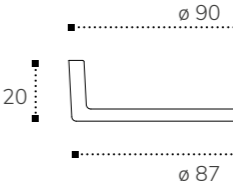
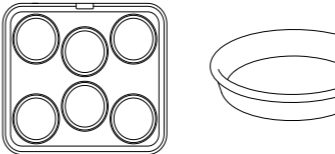
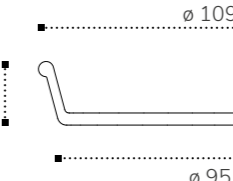
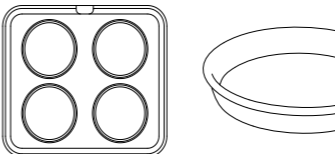
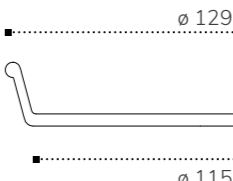
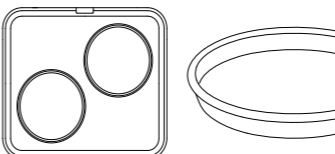
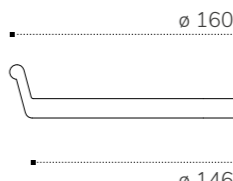
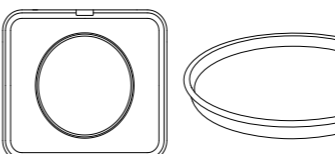
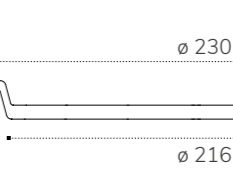
	CODE	DIMENSIONI DIMENSIONS (mm)	SPESSORE THICKNESS (mm)
	PIASTRA 41		pareti - borders 3,5 fondo - bottom 3,5
	PIASTRA 45		pareti - borders 5 fondo - bottom 4
	PIASTRA T		pareti - borders 3 fondo - bottom 4
	PIASTRA S		pareti - borders 3 fondo - bottom 4
	PIASTRA Z		pareti - borders 4 fondo - bottom 8
	PIASTRA V		pareti - borders 4 fondo - bottom 8

Triangolari - Triangular

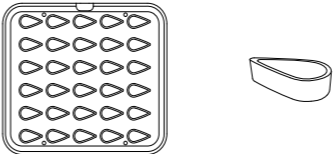
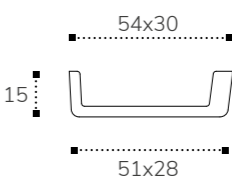
	CODE	DIMENSIONI DIMENSIONS (mm)	SPESSORE THICKNESS (mm)
	PIASTRA 22		pareti - borders 3,5 fondo - bottom 3,5

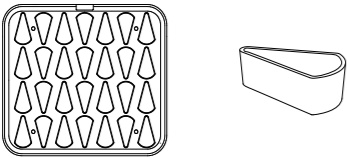
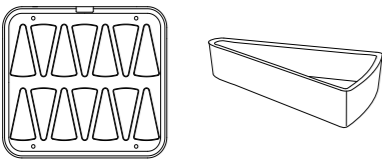

	CODE	DIMENSIONI DIMENSIONS (mm)	SPESSORE THICKNESS (mm)
	PIASTRA 19	70x40 67x37 115x60	pareti - borders 3,5 fondo - bottom 4,5
	PIASTRA 18	67x37 115x60 111x56	pareti - borders 3,5 fondo - bottom 4,5

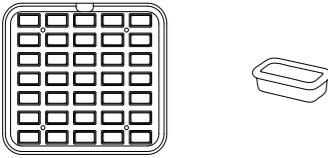
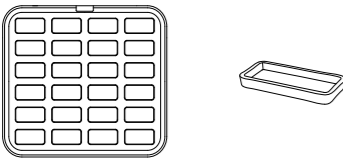
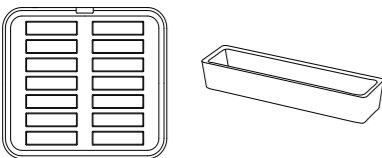
Rettangolari - Rectangular

	CODE	DIMENSIONI DIMENSIONS (mm)	SPESSORE THICKNESS (mm)
	PIASTRA Q	52x29 44x21	pareti - borders 3 fondo - bottom 4
	PIASTRA 4	70x33 67x31	pareti - borders 3 fondo - bottom 3
	PIASTRA X	120x30 117x27	pareti - borders 3 fondo - bottom 3,5

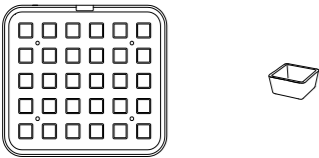
Quadrate - Squared

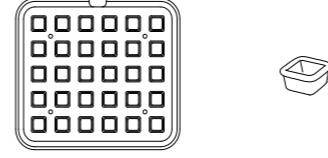
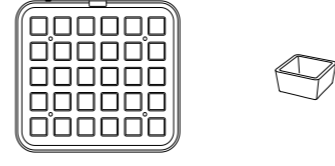
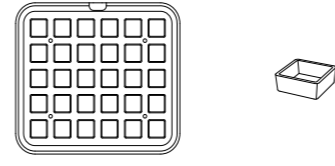
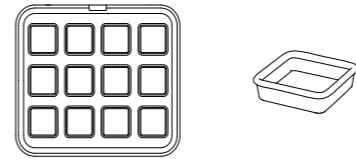
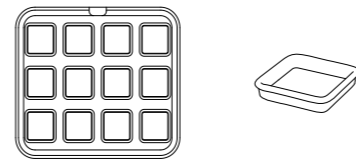
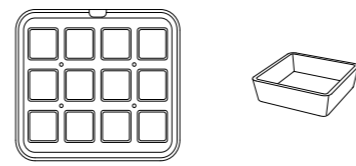
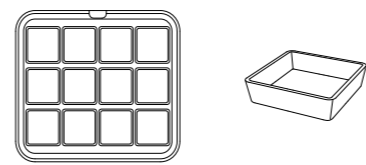
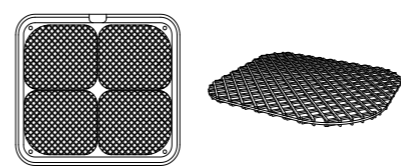
	CODE	DIMENSIONI DIMENSIONS (mm)	SPESSORE THICKNESS (mm)
	PIASTRA 10	33x33 28x28	pareti - borders 3 fondo - bottom 4

	CODE	DIMENSIONI DIMENSIONS (mm)	SPESSORE THICKNESS (mm)
	PIASTRA P	34x34 26x26	pareti - borders 3 fondo - bottom 4
	PIASTRA 3	40x40 35x35	pareti - borders 3,5 fondo - bottom 3,5
	PIASTRA 27	40x40 38x38	pareti - borders 3,5 fondo - bottom 3,5
	PIASTRA UM	69x69 60x60	pareti - borders 3 fondo - bottom 4
	PIASTRA U	69x69 62x62	pareti - borders 3 fondo - bottom 4
	PIASTRA 34	70x70 65x65	pareti - borders 4 fondo - bottom 4
	PIASTRA 35	80x80 74x74	pareti - borders 4 fondo - bottom 4
	PIASTRA L	170 140	5 :  : 2

Cuore - Heart

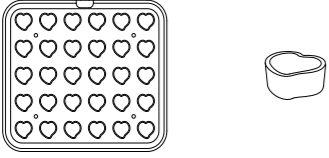
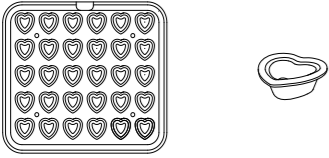
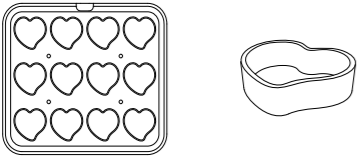
	CODE	DIMENSIONI DIMENSIONS (mm)	SPESSORE THICKNESS (mm)
	PIASTRA 60	40x38 17 37x35	pareti - borders 3 fondo - bottom 3
	PIASTRA 1	46x45 18 27x26	pareti - borders 3 fondo - bottom 3
	PIASTRA 59	76x71 20 73x68	pareti - borders 3,5 fondo - bottom 3,5

Festonate - Festooned

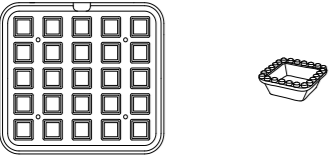
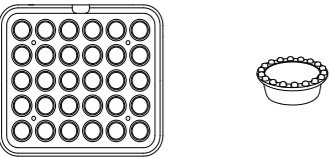
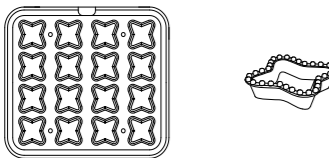
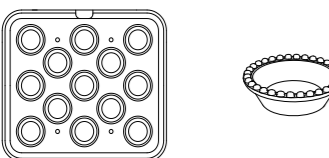
	CODE	DIMENSIONI DIMENSIONS (mm)	SPESSORE THICKNESS (mm)
	PIASTRA G	45x45 19 30x30	pareti - borders 3 fondo - bottom 5
	PIASTRA B	ø 47 18 ø 36	pareti - borders 3 fondo - bottom 5
	PIASTRA H	62x62 18 47x47	pareti - borders 3,5 fondo - bottom 5
	PIASTRA A	ø 67 21 ø 43	pareti - borders 4 fondo - bottom 6

CODE





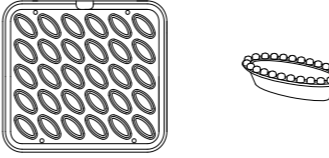
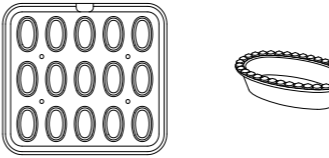
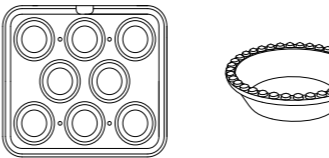
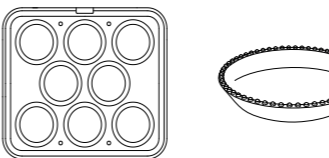



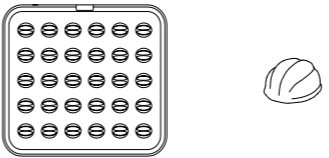
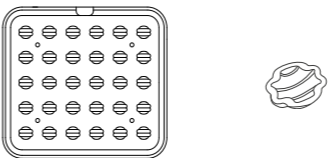
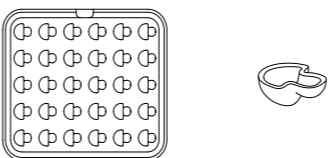

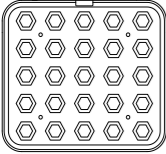
**DIMENSIONI
DIMENSIONS (mm)**

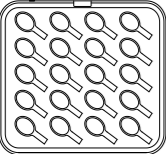
**SPESSORE
THICKNESS (mm)**

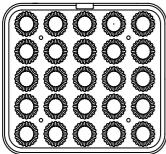
	PIASTRA E	67x33 18 51x17	pareti - borders 3 fondo - bottom 5
	PIASTRA C	77x48 20 60x32	pareti - borders 3,5 fondo - bottom 5,5
	PIASTRA F	ø 90 25 ø 62	pareti - borders 3,5 fondo - bottom 6
	PIASTRA 6	ø 98 17 ø 78	pareti - borders 3 fondo - bottom 4

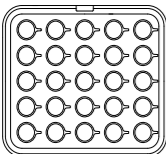
Altre forme - Other shapes

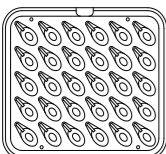
	CODE	DIMENSIONI DIMENSIONS (mm)	SPESSORE THICKNESS (mm)
	PIASTRA 5	17 39x33	pareti - borders 3 fondo - bottom 3
	PIASTRA N	18 40x34	pareti - borders 3 fondo - bottom 3,5
	PIASTRA Y	40x35 17	pareti - borders 3 fondo - bottom 3

	CODE	DIMENSIONI DIMENSIONS (mm)	SPESSORE THICKNESS (mm)
		PIASTRA 14	<p>46x40</p> <p>25</p> <p>31x27</p> <p>pareti - borders 3,5</p> <p>fondo - bottom 4,5</p>
		PIASTRA K	<p>50x38</p> <p>11</p> <p>78</p> <p>pareti - borders</p> <p>fondo - bottom from 3 to 4</p>
		PIASTRA 00	<p>ø 55</p> <p>16</p> <p>ø 35</p> <p>pareti - borders 3,5</p> <p>fondo - bottom 4</p>
		PIASTRA 8	<p>ø 57</p> <p>ø 44</p> <p>23</p> <p>ø 26</p> <p>pareti - borders 3</p> <p>fondo - bottom 3</p>
		PIASTRA R	<p>68</p> <p>48x33</p> <p>15</p> <p>20x13</p> <p>pareti - borders 4</p> <p>fondo - bottom 4</p>

Piastre pâte à choux per Cookmatic Pâte à choux plates for Cookmatic

Quattro diverse piastre per la realizzazione di pâte à choux di forma sempre perfetta: cubo, cilindro, éclair tonda e rettangolare.

I dettagli realizzativi permettono la creazione di preparazioni cave pronte da farcire e decorare, un accoppiamento sulla macchina sempre ideale e la massima efficienza di resa.

Four different plates for the realization of always perfect pâte à choux: cube, cylinder, round éclair and rectangular éclair.

The manufacturing details allow the creation of hollow preparations ready to be stuffed and decorated, a coupling on-the machine always ideal and maximum efficiency of performance.

Il dettaglio che cambia tutto: la scanalatura

Scanalature in rilievo su tutto il perimetro delle forme consentono la fuoriuscita del vapore, in modo regolare. L'impasto si espande così durante la cottura, diventando cavo, pronto per essere farcito.

The detail that changes everything: the groove

Grooves in relief on the entire perimeter of the shapes allow the vapor to escape, in a regular way. The dough expands during cooking, becoming hollow, ready to be filled.

Una cottura perfetta

Grazie alla programmazione di Cookmatic, al mantenimento ideale della temperatura e ai dettagli del design delle piastre, la cottura delle pâte à choux risulta sempre perfetta. A fine processo otterrai una cavità ideale per essere farcita. Per le temperature consigliate e i tempi di cottura consulta le ricette alle pagine 114-121.

Perfect baking

Thanks to the Cookmatic programming, the ideal temperature maintenance and the details of the plate design, the cooking of the pâte à choux is always perfect. At the end of the process you will get an ideal cavity to be filled. For recommended temperatures and cooking times see the recipes on pages 114-121.



Guarda il video dedicato a **Cookmatic per pâte à choux** sul canale Youtube di Pavoni Italia

Watch the video "**Cookmatic for pâte à choux**" on Pavoni Italia's Youtube channel



NEW

Cubo
Cube

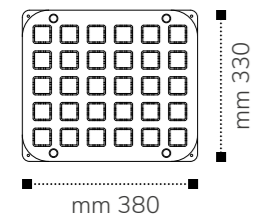

CODE	IMPRONTE INDENTS	DIMENSIONI DIMENSIONS (mm)	PESO WEIGHT (g)
PIASTRACHOUX01	30	32	crudo - raw ~ 7,5 cotto - baked ~ 4 farcito - filled ~ 25

NEW

Cilindro
Cylinder

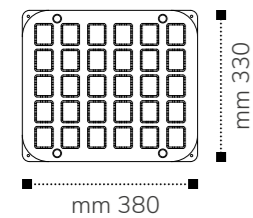

CODE	IMPRONTE INDENTS	DIMENSIONI DIMENSIONS (mm)	PESO WEIGHT (g)
PIASTRACHOUX02	30	Ø 32 40	crudo - raw ~ 8 cotto - baked ~ 4 farcito - filled ~ 25

NEW

Éclair rettangolare
Rectangular éclair

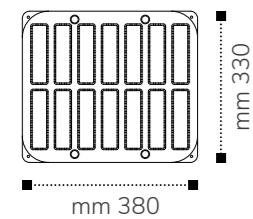

CODE	IMPRONTE INDENTS	DIMENSIONI DIMENSIONS (mm)	PESO WEIGHT (g)
PIASTRACHOUX03	14	120 30	crudo - raw ~ 24 cotto - baked ~ 18 farcito - filled ~ 80

NEW

Éclair tonda
Round éclair

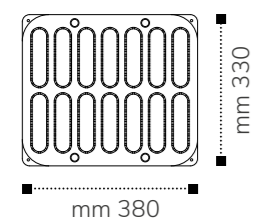

CODE	IMPRONTE INDENTS	DIMENSIONI DIMENSIONS (mm)	PESO WEIGHT (g)
PIASTRACHOUX04	14	120 30	crudo - raw ~ 23 cotto - baked ~ 11 farcito - filled ~ 80



Raccomandazioni d'uso - Recommendations for use

Dosaggio con sac à poche in piastra - Dosing with sac à poche in plate

Preriscalda le piastre. Per le temperature consigliate e i tempi di cottura consulta le ricette (pp. 114-121).

Preheat the plates. For recommended temperatures and cooking times see the recipes (pp. 114-121).

Per un utilizzo immediato e risultati da esporre subito in vetrina, puoi dressare l'impasto direttamente nelle piastre, utilizzando una sac à poche (cod. **ELITE**). Per ottenere un risultato ottimale, consigliamo di riempire solo circa 3/4 delle impronte della piastra.

For immediate use and results to be displayed in the shop window, you can dress the dough directly in the plates, using a disposable piping bag (cod. **ELITE**). For a better result, we recommend to fill the indents of the plate approximately to 3/4 of the way full.

Cuoci con Cookmatic.

Cook with Cookmatic.

Estrai gli choux dalle piastre e falli raffreddare su griglia (cod. **GLA64**).

Remove the choux from the plates and let them cool on grid (cod. **GLA64**).

Farcisci, decora a piacimento ed esponi direttamente in vetrina.

In alternativa, congela gli choux vuoti o farciti; conservali con Covering (cod. **COVER55, COVER85, TRAY**); rigenera, farcisci e decora.

Stuff, decorate at will and expose directly in the shop window.

Alternatively, freeze empty or stuffed choux; preserve them with Covering (cod. **COVER55, COVER85, TRAY**); regenerates, fills and decorates.



ELITE

Sac à poche monouso
Disposable piping bags

disponibile in varie misure
available in different sizes

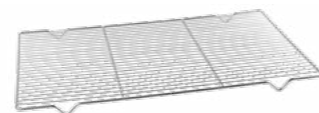

GLA64

Griglia in acciaio
Steel grid

600x400 mm



COVERING

Coperchi e vassoio per
stoccaggio e conservazione
Lids for storage and keeping



SPV64

Tappetino in silicone
Silicone mat

585x385 mm

New Cookmatic Special

Per tartellette con altezze da record!
For tartlets with record heights!

Con Cookmatic Special puoi realizzare tartellette alte 45 mm, grazie allo speciale meccanismo di scorrimento regolabile in altezza brevettato da Pavoni Italia. Scegli tra le differenti coppie di piastre disponibili e realizza basi di varie forme per tartellette e pastafrolla dolce e salata: grazie all'accoppiamento perfetto delle due piastre otterrai tartellette sempre perfette per dimensione e cottura. La nuova interfaccia permette una più facile ed intuitiva programmazione. Cookmatic Special è facile da pulire ed è adatta alla produzione in continuo per diverse ore. **2 anni di garanzia.**

With Cookmatic Special you can create 45mm-high tartlets, thanks to the special height-adjustable sliding mechanism patented by Pavoni Italia. Choose from the different pairs of plates available and make bases of various shapes for tartlets and sweet and savoury pastries. The perfect coupling of the two plates will always give you perfectly-sized tartlets ready for cooking. The new interface allows for easier and more intuitive programming. Cookmatic Special is easy to clean and suitable for continuous production over several hours.

2 year warranty.

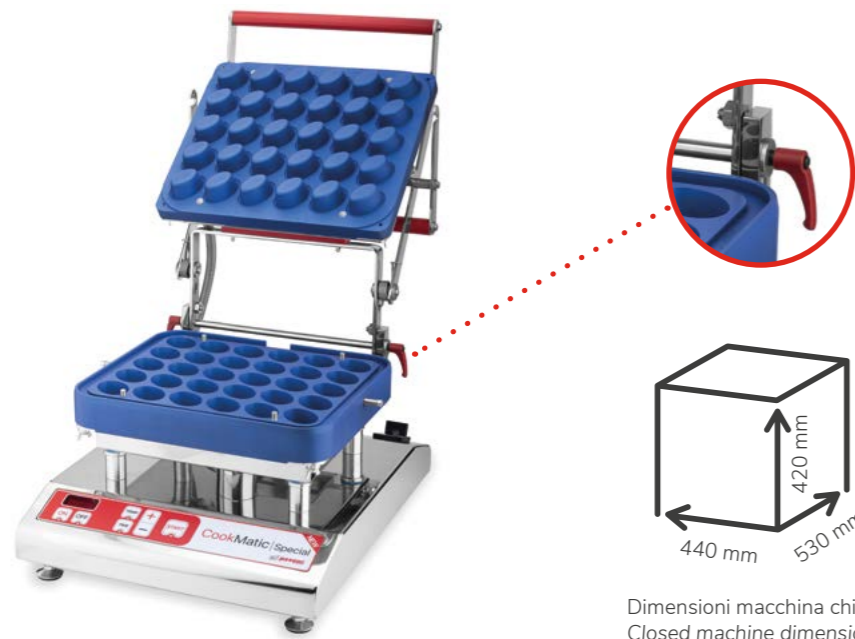

Dimensioni macchina chiusa
Closed machine dimensions

CODE	PESO WEIGHT (kg)	POTENZA ELETTRICA ELECTRICAL POWER (Watt)	TENSIONE ELETTRICA ELECTRICAL VOLTAGE (Volt)
NEWCOOKMATICSSPECIAL	28	3200	220/240 volt *110/380 volt





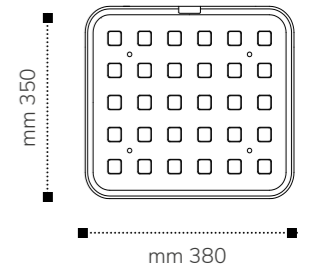

* a richiesta
on demand

Piastre per Cookmatic Special Plates for Cookmatic Special

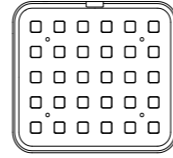
Peso piastra - Plate weight kg 15

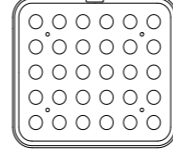
(variabile a seconda della piastra - variable depending on the plate)

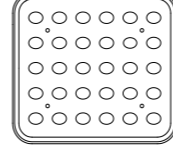

CODE	DIMENSIONI DIMENSIONS (mm)	SPESSORE THICKNESS (mm)
  PIASTRA S05	26x26 35	pareti - borders 3,5 fondo - bottom 3,5
  PIASTRA S03	22x22 ø 31 35	pareti - borders 3 fondo - bottom 3,5
  PIASTRA S04	ø 27 33x25 35 29x21	pareti - borders 3,5 fondo - bottom 3,5

Accessori per New Cookmatic e Cookmatic Special New Cookmatic and Cookmatic Special accessories

Carrello in acciaio inox AISI 304 - AISI 304 stainless steel trolley



CODE	PESO WEIGHT (Kg)	DIMENSION (mm)
CARCOOK	22,5	550x460x840 h

2 ruote con freno e 2 normali Ø mm 100

2 wheels with brakes and 2 normal wheels Ø mm 100

Cookmatic Maxi

Maxi formato, maxi resa.
Large format, large yield.

Una grande novità per migliorare ancora di più la tua produttività. Con Cookmatic Maxi puoi realizzare fino al 50% in più di tartellette nello stesso tempo, grazie alla piastra di dimensioni maggiorate. Cookmatic Maxi è particolarmente adatta alla preparazione di basi medio-grandi sia dolci che salate, adatte sia alla pasticceria sia alla ristorazione. Ottieni cottura e dettagli sempre perfetti: programma il tuo lavoro con la nuova interfaccia, resa ancora più semplice ed intuitiva. Cookmatic Maxi è facile da pulire ed è adatta alla produzione in continuo per diverse ore. **2 anni di garanzia.**

A big update that will improve your productivity even more. Thanks to the oversized plates, you can now make up to 50% more tartlets at the same time with Cookmatic Maxi. Cookmatic Maxi is ideal for the preparation of medium to large sweet and savoury bases suitable for both pastry and catering sector. The new simpler and more intuitive interface lets you program your work, so you get all your details just right and a perfect cook every time. Cookmatic Maxi is easy to clean and suitable for continuous production over several hours. **2 year warranty.**

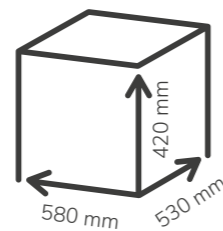

Dimensioni macchina chiusa
Closed machine dimensions

CODE	PESO WEIGHT (kg)	POTENZA ELETTRICA ELECTRICAL POWER (Watt)	TENSIONE ELETTRICA ELECTRICAL VOLTAGE (Volt)
COOKMATICMAXI	37	5000	380 volt





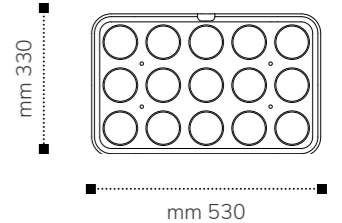

Piastre per Cookmatic Maxi Plates for Cookmatic Maxi

Piastre più grandi per una migliore produttività. Cookmatic Maxi ha una selezione dedicata di piastre di grande formato tra le quali scegliere, con le forme di maggiore impiego nel mondo del catering, della ristorazione e della pasticceria.

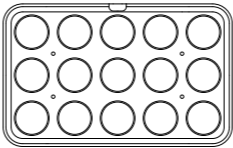

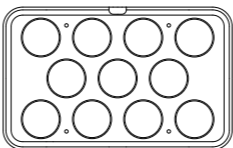
Larger plates for better productivity. Cookmatic Maxi has a dedicated selection of large format plates to choose from, including some of the most widely used moulds in the catering, restaurant and pastry world.

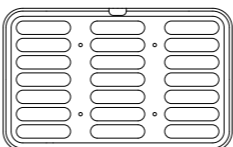
Peso piastra - Plate weight kg 15 (variabile a seconda della piastra - variable depending on the plate)

	CODE	DIMENSIONI DIMENSIONS (mm)	SPESSORE THICKNESS (mm)
	 MAXIW	$\phi 80$ 20 $\phi 76$	pareti - borders 3,5 fondo - bottom 4
	 MAXI45	$\phi 90$ 20 $\phi 87$	pareti - borders 5 fondo - bottom 4
	 MAXI38	126x32 15 123x30	pareti - borders 3,5 fondo - bottom 3,5

Su richiesta, tutte le forme disponibili per la Cookmatic possono essere adattate al formato di piastra più grande per la Cookmatic Maxi. - All shapes available for the Cookmatic can be adapted to a bigger plate's size for Cookmatic Maxi, on demand.



Guarda il video dedicato a **Cookmatic Maxi** sul canale Youtube di Pavoni Italia
Watch the video "**Cookmatic Maxi**" on Pavoni Italia's Youtube channel

