



Architect/Engineering Specifications:

Stainless steel single hole deck mount mixing faucet, add-on faucet, 6" swing nozzle with stream regulator outlet, 8" riser, 24" flexible hose with heat resistant handle, 1.15 GPM spray valve, compression cartridges with spring checks, lever handles, 18" flexible supply hoses with G1/2 female swivel connections, 6" adjustable wall bracket, spray valve holder, and overhead spring. Certified to ASME A112.18.1/CSA B125.1, NSF 61-Section 9 and NSF 372. 2019 DOE PRSV - Class II compliant.

Job Name _____

Model Specified _____ Quantity _____

Variations Specified _____

Date _____

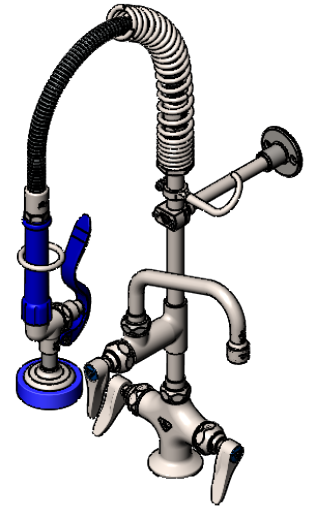
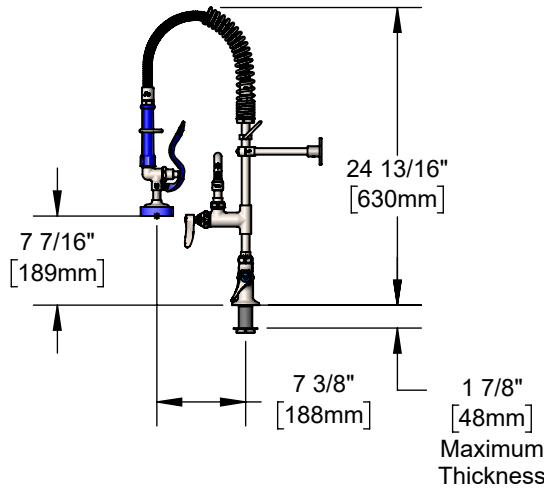
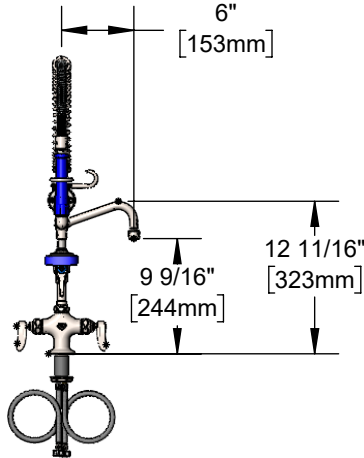

Features & Benefits:

- All stainless steel construction with brushed finish
- Single hole deck mount mixing faucet w/ stainless steel body
- Stainless steel EasyInstall add-on faucet
- Stainless steel 6" swing nozzle w/ stream regulator outlet, Series 1
- Stainless steel 8" rigid riser
- 24" flexible stainless steel hose w/ heat resistant blue handle and hold down ring
- Stainless steel 1.15 GPM spray valve
- Stainless steel quarter-turn Eterna compression cartridges w/ spring checks to prevent cross flow of water
- Stainless steel lever handles w/ color coded indexes
- 18" flexible stainless steel supply hoses w/ G1/2 female swivel connections (compatible w/ 1/2" NPSM threads)
- Stainless steel 6" adjustable wall bracket
- Material: Stainless steel body, tubular nozzle, add-on faucet body, riser, spray valve, hose, cartridges and handles

Product Compliance:

- ASME A112.18.1 / CSA B125.1
- NSF 61 - Section 9
- NSF 372 (Low Lead Content)
- 2019 DOE PRSV - Class II
- For Commercial Use Only



Warranty: Lifetime (Limited)

Performance Data:

- Pressure: 20 - 125 psi [1.38 - 8.62 bar]
- Temperature: 40°F - 140°F [4.44°C - 60°C]
- Flow Rate:
 - Spray Valve: 1.15 GPM [4.35 L/min] @ 60 psi [4.14 bar]
 - Add-On Faucet: 5.57 GPM [21.08 L/min] @ 60 psi [4.14 bar]

Stainless Steel T&S Swing Nozzles

- S059X 6" Swing Nozzle (Standard)
- S060X 8" Swing Nozzle
- S062X 12" Swing Nozzle

Stainless Steel Optional Pre-Rinse Spray Valves

- S-0107 (1.15 GPM) (Standard)
- S-0107-J (1.07 GPM)

