

Shortening Disposal Unit (PSDU50 and PMSDU50)

Installation, Operation and Service Manual

This manual is updated as new information and models are released. Visit our website for the latest manual.



⚠ CAUTION
READ THE INSTRUCTIONS BEFORE USING.



Part Number: FRY_IOM_8197540 05/2018

Original Instructions

NOTICE

IF, DURING THE WARRANTY PERIOD, THE CUSTOMER USES A PART FOR THIS FRYMASTER FOOD SERVICE EQUIPMENT OTHER THAN AN UNMODIFIED NEW OR RECYCLED PART PURCHASED DIRECTLY FROM FRYMASTER, OR ANY OF ITS AUTHORIZED SERVICE CENTERS, AND/OR THE PART BEING USED IS MODIFIED FROM ITS ORIGINAL CONFIGURATION, THIS WARRANTY WILL BE VOID. FURTHER, FRYMASTER AND ITS AFFILIATES WILL NOT BE LIABLE FOR ANY CLAIMS, DAMAGES OR EXPENSES INCURRED BY THE CUSTOMER WHICH ARISE DIRECTLY OR INDIRECTLY, IN WHOLE OR IN PART, DUE TO THE INSTALLATION OF ANY MODIFIED PART AND/OR PART RECEIVED FROM AN UNAUTHORIZED SERVICE CENTER.

NOTICE

This unit is intended for professional use only and is to be operated by qualified personnel only. A Frymaster Factory Authorized Servicer (FAS) or other qualified professional should perform installation, maintenance, and repairs. Installation, maintenance, or repairs by unqualified personnel may void the manufacturer's warranty.

NOTICE

Drawings and photos used in this manual are intended to illustrate operational, cleaning and technical procedures and may not conform to on-site management operational procedures.

WARNING

Improper installation, adjustment, alteration, service or maintenance can cause property damage, injury or death. Read the installation, operating and maintenance instructions thoroughly before installing, operating or servicing this equipment.

WARNING

This appliance is not intended for use by children under the age of 16 or persons with reduced physical, sensory or mental capabilities, or lack of experience and knowledge, unless they have been given supervision concerning use of the appliance by a person responsible for their safety. Do not allow children to play with this appliance.

DANGER

Before each use inspect the cover to ensure the cover gasket is present and properly placed. **DO NOT** use the disposal unit if this gasket is damaged or missing.

WARNING

NEVER drain boil out or cleaning solution into a shortening disposal unit (SDU). This units are not intended for this purpose, and will be damaged by the solution and void the warranty.

DANGER

Hot oil will cause severe burns. Allow oil to cool to 100°F (38°C) before draining into the shortening disposal unit (SDU) for disposal and before transporting to the disposal site. Use extreme caution when transporting and disposing of depleted oil.

DANGER

DO NOT drain more than one full frypot or two split frypots into the SDU at one time to avoid overflow and spillage of hot oil that may cause severe burns, slipping and falling.

DANGER

When draining oil into a disposal unit, do not fill above the maximum fill line located on the container.

WARNING

DO NOT leave shortening in the tank or allow shortening to solidify in the SDU.



Shortening Disposal Unit
Installation, Operation and Service Manual
TABLE OF CONTENTS

SECTION 1: INTRODUCTION

1.1	Service Information and Parts Ordering	1
1.2	Installation, Operating and Service Personnel	1
1.3	Definitions	1
1.4	Shipping Damage Claim Procedure	2
1.5	What to Do If Your Equipment Arrives Damaged	2

SECTION 2: ASSEMBLY AND OPERATION

2.1	Equipment Description.....	2
2.2	Equipment Assembly	2
2.3	Equipment Operation	3
2.4	Cleaning	4

SECTION 3: SERVICE PROCEDURES

3.1	Introduction	4
3.2	Replacing Worn or Damaged O-Rings	4

SHORTENING DISPOSAL UNIT (PSDU50 and PMDSU50) INSTALLATION, OPERATION AND SERVICE

1. INTRODUCTION

1.1 Service Information and Parts Ordering

A list of Factory Authorized Service Centers (FAS's) is located on the Frymaster website at www.frymaster.com. Refer to this list to find the FAS nearest you. If you do not have access to this list, contact the Frymaster Technical Service Department at 1-800-551-8633 or 1-318-865-1711.

Service information may be obtained by contacting your local FAS. Information may also be obtained by calling the Frymaster Technical Service Department at 1-800-551-8633 or 1-318-865-1711 or by e-mail: fryservice@welbilt.com. In order to assist you as quickly as possible, the FAS or Service Department representative requires certain information about your equipment. The information is printed on a data plate located on the tank cover. When requesting service or parts, please have the following information ready:

Model Number: _____
Serial Number: _____

In addition to the model number, and serial number, please be prepared to describe the nature of the problem and have ready any other information that you think may be helpful in solving your problem. Parts orders may be placed directly with your local FAS or distributor.

RETAIN AND STORE THESE INSTRUCTIONS IN A SAFE PLACE FOR FUTURE USE.

1.2 Installation, Operating and Service Personnel

Installation, Operating, and Service information for this equipment has been prepared for use by qualified and/or authorized personnel only, as defined in Section 1.3.

1.3 Definitions

QUALIFIED AND/OR AUTHORIZED OPERATING PERSONNEL

Qualified/authorized operating personnel are those who have carefully read the information in this manual and have familiarized themselves with the equipment functions, or who have had previous experience with the operation of the equipment covered in this manual.

QUALIFIED SERVICE PERSONNEL

Qualified service personnel are those who are familiar with this equipment and who have been authorized by Frymaster L.L.C. to perform service on equipment manufactured by Frymaster. All authorized service personnel are required to be equipped with a complete set of service and parts manuals, and to stock a minimum amount of parts for Frymaster equipment. A list of Factory Authorized Service Centers (FAS's) is located on the Frymaster website at www.frymaster.com.

Unless specifically indicated otherwise in this manual, failure to use qualified service personnel will void the Frymaster Warranty on this equipment.

1.4 Shipping Damage Claim Procedure

This equipment was carefully inspected and packed before leaving the factory. The transportation company assumes full responsibility for safe delivery upon acceptance of the equipment for transport.

1.5 What to Do If Your Equipment Arrives Damaged

1. **File a claim for damages immediately**, regardless of the extent of damages.
2. **Inspect for and record all visible loss or damage** and ensure that this information is noted on the freight bill or express receipt and is signed by the person making the delivery.
3. **Concealed loss or damage** that was unnoticed until the equipment was unpacked should be recorded and reported to the freight company or carrier **immediately** upon discovery. A concealed damage claim must be submitted within 15 days of the date of delivery. Ensure that the shipping container is retained for inspection.

**FRYMASTER DOES NOT ASSUME RESPONSIBILITY
FOR DAMAGE OR LOSS INCURRED IN TRANSIT.**

2. ASSEMBLY AND OPERATION

2.1 Equipment Description

The Shortening Disposal Unit (SDU) is designed for the safe transportation of used shortening or cooking oil from the kitchen to a disposal container. The SDU holds to 50 pounds/23 kg of cooking oil. The unit consists of a tank and a heavy-duty manual pump. It is equipped with 6 " (150 mm) wheels. The pump is mounted at a convenient height that allows it to be operated from a standing position. The height of the discharge pipe allows pumping directly into a standard 55-gallon drum.

With the cover open, the top of the tank is 9¾ inches (248 mm) above the floor, permitting it to be positioned directly beneath the drains of most fryers.

2.2 Equipment Assembly

Assembly of the unit is a four-step process:

1. Remove the two bolts from the handle-mounting bracket and raise the handle to the upright position. Reinstall the bolts in the bracket and tighten to 8 ft/lbs.
2. Ensure the O-rings and the bottom 2 inches of the suction tube are lubricated with *Accrolube with Teflon* or an equivalent light oil or grease.
3. Turn the pump and suction tube upside down and carefully pour no more than one cup of cooking oil down the tube. Rotate the pump handle slowly three or four times to prime the pump.
4. Insert the suction tube through the pipe bracket on the handle and into the pickup tube on top of the reservoir. Push down on the pump assembly and ensure the suction tube is fully seated.

2.3 Equipment Operation

WARNING

DO NOT use this unit to dispose of water or Boil-out solution. Introduction of water or solvents into the unit will permanently damage the pump and will void the warranty.

1. Turn the fryer off prior to draining into SDU. If so equipped, ensure the fryer drainpipe is firmly threaded into the frypot drain valve.
2. Open the cover, verify that the crumb screen and rubber gasket on the inside cover are in place, and position the unit so that the opening is directly under the frypot drainpipe.

NOTE: Long periods between use and debris allowed to enter the check valve can cause the unit to require priming before reuse. See step 3 in the assembly section.

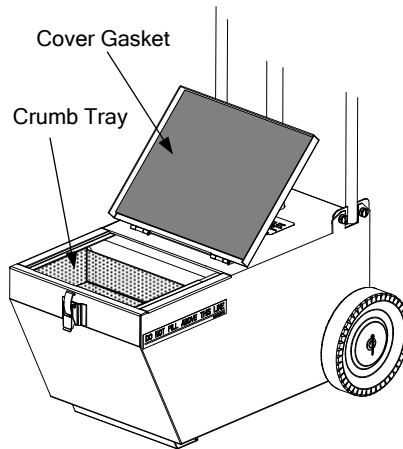

DANGER

Before each use inspect the cover to ensure the cover gasket is present and properly placed. DO NOT use the disposal unit if this gasket is damaged or missing.

3. **Slowly** open the drain valve. Regulate flow with the drain valve to prevent splashing.

DANGER

DO NOT OVERFILL! Do not fill the reservoir above the fill lines on the sides of the reservoir. Moving the SDU with an overfilled reservoir may result in spills and injury to personnel who come in contact with the spilled shortening.

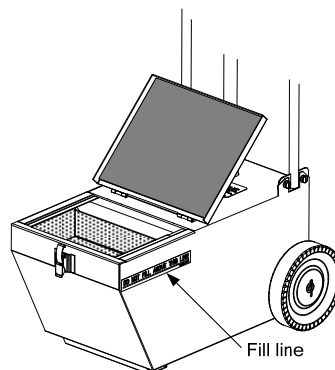

- Carefully withdraw the unit far enough to allow the cover to be closed. Latch the cover in the closed position. Using the handle, carefully tip the unit back slightly for ease of handling and roll the unit to the disposal site.

 **WARNING**

DO NOT use the pump or discharge piping assembly as a handle!

 **DANGER**

To minimize the potential for burns, oil must always be allowed to cool below 100°F (38°C) before draining into the SDU and transporting to the disposal area. However, DO NOT leave shortening in the tank or allow shortening to solidify in the SDU.

The unit is designed to be moved, when properly filled, at an average walking pace on a flat surface. ***Care must be taken at all times when moving hot shortening or oil. Rough terrain or sudden stops and starts may cause the contents of the reservoir to spill or splash out of the reservoir, possibly causing serious injury to personnel. Always ensure that the cover is latched shut when moving the unit.***

- At the disposal site, lift the pump assembly lock pin and rotate the discharge pipe as necessary to position the discharge nipple over the opening of the disposal container. Release the lock pin to secure the pump assembly in position. Turn the pump handle clockwise. The pump should start discharging oil after a few turns. Continue turning the handle until the SDU reservoir is empty.

2.4 Cleaning

Clean the crumb screen with a solution of detergent and water. Clean the ***exterior surfaces*** of the SDU with a soft cloth and a solution of detergent and water. It is not necessary to clean the interior of the reservoir, but if desired it may be wiped down with clean paper towels to remove excess residual shortening.

 **WARNING**

DO NOT clean the interior of the reservoir with water or detergent. Introduction of water or detergent into the unit will permanently damage the pump.

3. SERVICE PROCEDURES

3.1 Introduction

Other than routine cleaning and the replacement of worn suction tube O-rings, the SDU is maintenance free. After long use, the pump vanes and pump shaft seal may require replacement due to wear. Frymaster recommends worn pump vanes and/or pump shaft seals be replaced by an FAS, but store personnel may perform these service actions without voiding the warranty.

3.2 Replacing Worn or Damaged O-Rings

If pump efficiency degrades, it is likely that the O-rings on the suction tube are worn or damaged. To replace the O-rings, follow the steps below.

- Lift the pump assembly straight up and out of the handle assembly.

2. Remove the worn or damaged O-rings from the grooves at the bottom of the suction tube and replace with new O-rings. Apply *Accrolube with Teflon* grease or equivalent to bottom 2 inches of the suction tube.
3. Insert the suction tube through the tube bracket in the handle and into the receiver on top of the reservoir. Push down on the pump assembly to make sure the suction tube is fully seated.

THIS PAGE INTENTIONALLY LEFT BLANK

Manufactured at Foshan Manitowoc Foodservice Col, Ltd.
No.12 Chuang Ye North Road, Song Gang Song Xia Industry Park
Nanhai District, Foshan Guangdong, China 528234

**WELBILT®**
*Bringing innovation to the table***WWW.WELBILT.COM**

Welbilt provides the world's top chefs, and premier chain operators or growing independents with industry leading equipment and solutions. Our cutting-edge designs and lean manufacturing tactics are powered by deep knowledge, operator insights, and culinary expertise. All of our products are backed by KitchenCare® – our aftermarket, repair, and parts service.

▼ CLEVELAND ▼ DELFIELD® ▼ FRYMASTER® ▼ KOLPAK® ▼ MANITOWOC® ▼ MERRYCHEF®
▼ CONVOTHERM® ▼ FITKITCHEN™ ▼ GARLAND ▼ LINCOLN ▼ MERCO® ▼ MULTIPLEX®