

AUTOMATIC ROUNDER DIVIDER

DAAxxx



Power (kW)-(hp)

400~230V.3ph-50~60Hz – 1,3 (1,7)

Net weight (Kg)-(lb)

385 (849)

Dimensions (mm)-(in)

A 700 (27 9/16) B 640 (25 3/16) B1 240 (9 7/16)

C 1670 (65 3/4) C1 1800 (70 7/8)

D 950 (37 6/16) E 100 (3 15/16)

Heads* The minimum and maximum capacities will depend on fermentation, hydration and the flours used.

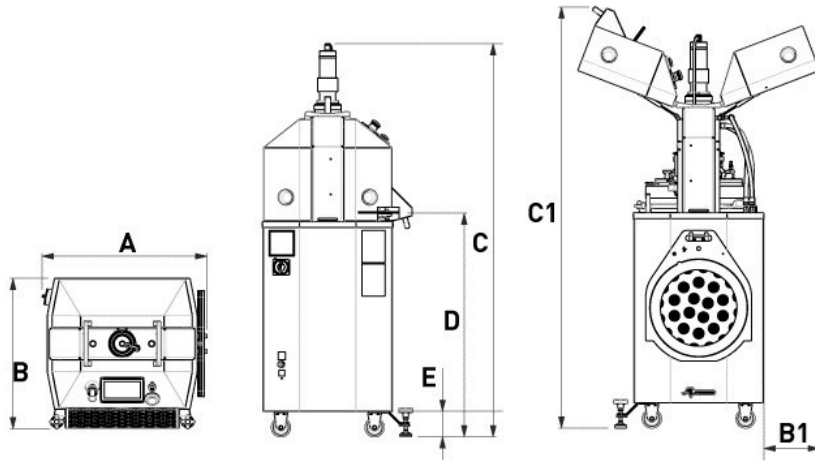



Standard-production equipment

INOX - Stainless steel frame, with castors

Stainless steel knives

Dough press and ring built in DIN POM C

Removable and interchangeable head (wide range from 15g to 300g / unit)

2 rounding systems (hard and soft doughs, from 45 to 75% hydration)

99 recipes with customized adjustments: pressing, cutting and rolling time

Responsive colour, touchscreen 9,7", capacitive, with recipe backup and different user access level

Advice on processes and daily maintenance

CE

Options

UL-NSF

NR12

Accessories

Removable head ø 410mm: 15, 22, 30 and 36 units

Removable head ø 364mm: 30, 36 and 54 units

PET excentric plate

Arc ø 410mm

Arc ø 364mm

Plate ø 410mm

Plate ø 364mm