

# SEMI-AUTOMATIC ROUNDER DIVIDER WITH INTERCHANGEABLE HEAD

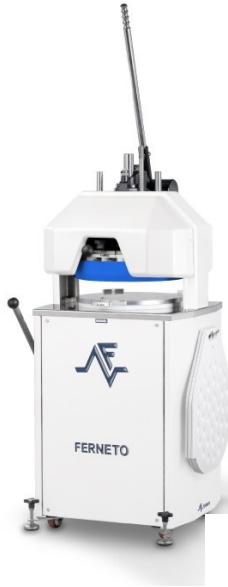

## Power (kW)-(hp)

230~120V.1ph.50~60Hz 0,55 (0,75)  
400~230V.3ph.50~60Hz 0,55 (0,75)

## Net weight (Kg)-(lb)

355 (783)

## Dimensions (mm)-(in)

A 760 (29 15/16) B 730 (28 3/4) B1 980 (38 9/16)  
C 1960 (77 3/16) C1 1600 (63) D 820 (32 5/16)  
E 100 (3 15/16) F 970 (38 3/16)

CC\_009.1-2Heads\* The minimum and maximum capacities will depend on fermentation, hydration and the flours used.

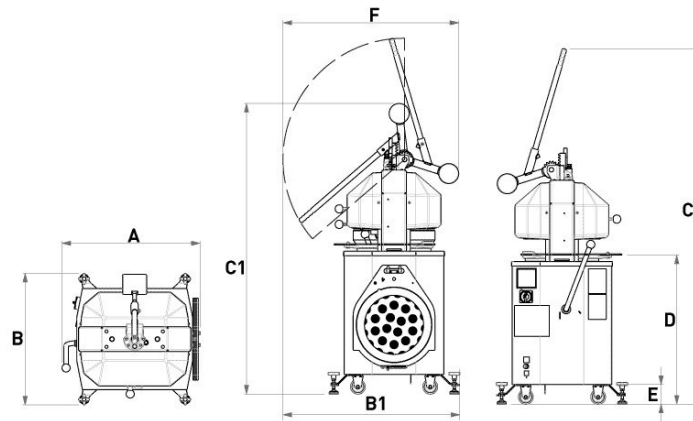

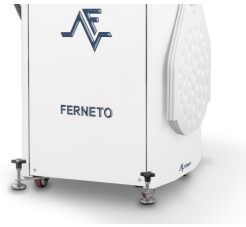

### **Standard-production equipment**

White painted carbon steel frame. 100mm floor raised, with castors

Stainless steel arc head support

Stainless steel knives

Dough press and ring built in DIN POM C

Anti-vibration system in stainless steel

Removable and interchangeable head (wide range from 15g to 300g / unit)

Free spare parts kit (springs and stopper)

NR12

CE

Options

Inox - Stainless steel frame. 100mm floor raised

USPHS - USPHS upgrade to inox models

UL-NSF

Accessories

Removable head ø 410mm: 15, 22, 30 and 36 units

Removable head ø 364mm: 30, 36 and 54 units

Arc ø 410mm

Arc ø 364mm

Plate ø 410mm

Plate ø 364mm