

New



« A » model, in standard version



« AGP » model with grid option

Divimach

Hydraulic divider



The Divimach hydraulic divider is an automatic machine designed to **divide dough into equal pieces**.

In a single operation **Divimach can divide a block of dough into 10 or 20 pieces of dough** of 200 g to 2 kg.

The **AGP model** can be fitted with a grid designed to prepare buns, ciabattas, triangles, etc.



The Divimach hydraulic divider has a wide range of hi-tech features and solutions gained from years of experience in artisan bakeries and supermarkets. Today, it is quite common for dividers to operate for 16 hours non-stop. Numerous components wear out and traditional solutions have reached their limits. The Divimach is Bongard's answer to these problems which currently affect all professionals.

The « Dust Control » system

Because your health is one of our priorities, the Divimach is equipped with the "Dust Control" system.

Unlike standard dividers that eject the flour outside the bowl during the pressing cycle, the Divimach uses this air flow to guide the flour dust into an air tight system at the end of which it is recovered.

The user can simply remove the flour dust collector drawer and empty it or vacuum up the contents.



Flour dust collector drawer

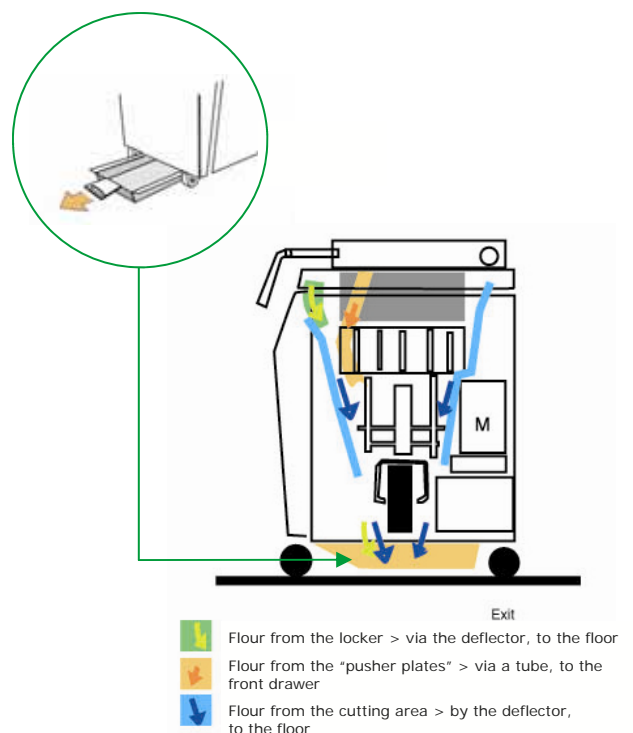

Divimach, a concentrate of technology

The « Stop & Go » system

Controlling oil temperature: guarantees equipment durability and saves energy

In "old-generation" dividers, there were many problems with heating the oil in the pump, which is used to operate the piston that controls the movement of pusher plates and knives. With the Divimach, **the pump is controlled by a micro-processor that automatically shuts it down when no oil pressure is required.**

This "Stop & Go" function reduces operating time by 60 %.

During a cycle time of approximately 40 seconds, including loading and unloading of the dough, the pump will only run for 15 seconds.

In addition to service and maintenance savings for oil heating, the technology has several advantages:

- Energy saving
- Less noise within the bakery
- Reduced maintenance (due to less frequent oil replacement)

Controlled technology

■■■ Locking the knives: an automatic system for perfect precision

In "old-generation" dividers, the knives were controlled separately from the pusher plates. Removing the knives before pressing the dough caused it to go out of shape as the dough tried to separate under pressure.

The Divimach includes an electrical locking system that prevents the warping of knives before the pusher plates rise. Whatever the density of the dough inside the bowl, its integrity is guaranteed.

■■■ A double action cylinder, for a long lasting mechanism

For most dividers, it is quite common for the pusher plates and knives to be retracted by springs. Over time, these springs wear out, the lowering of the pusher plates becomes hazardous, increasing the number of technical incidents.

The situation is made worse by cleaning difficulties that gradually lead to clogging.

For this reason, the system was abandoned for the Divimach and replaced **by a double action cylinder** that guarantees the perfect return of the main piston to its original position.

■■■ Deflector for protecting the motor and solenoid valves

Just as it protects your airways from the suspended flour released during standard division, the Divimach protects the motor and solenoid valve (❶).

Flour particles are filtered by two stretched canvas deflectors. The dust is then guided to the collection drawer.

The « Soft Dough » system

The "**Soft Dough**" system is used to divide delicate or highly hydrated dough, or even fermented dough, without degassing it, using a device to control average pressure.

The division can then be done without damaging the dough.



Before division



Soft Dough division



When design and ergonomics coincide...

A deliberately angular design

At Bongard, there is no question of creating a design just for the sake of it!

The Divimach design therefore provides a solution to the significant issues of working comfort and ergonomics.

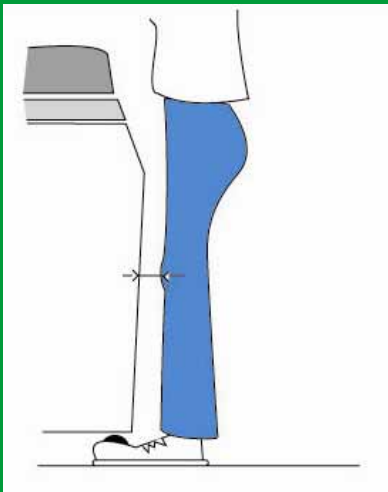

The shape of the front panel was specially designed and built around the Divimach control panel.

In particular, it lets you get as close as possible to the machine, to avoid handling loads at arms length.



An ergonomic handle protects the control panel

Acting as a bumper, this handle protects the control panel against impacts: A genuine ergonomic asset, it leads to a much more natural movement when opening and closing the Divimach.



Whatever the height of the user, it is no longer necessary to stand on tiptoes to reach it when the lid is raised.

When closing, the movement induced by the handle will protect the elbow joints and bring your hands directly back to control panel level (❶).

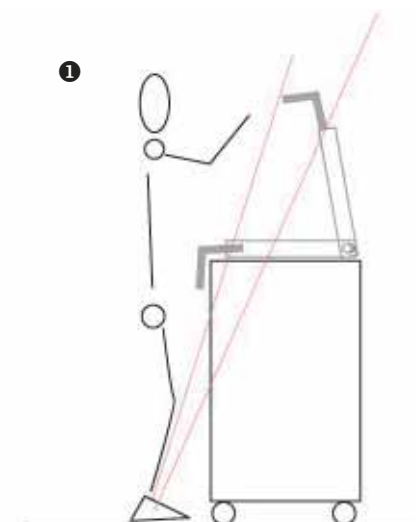

The Divimach control panel, a true control station

All actions are controlled by a microprocessor to guarantee their precision and reliability.

Centralised on the control panel, they allow **access to all functions and indicators on a single console.**

This system is also used to control the lowering of the pusher plates so that the depth of the bowl can be adjusted and adapted to the quantity of dough being divided.

A short press generates controlled lowering, whereas a long press enables complete lowering.

It is therefore not necessary to bend down to drop the dough into the bottom of the dough compartment.



"A" Model



"AGP" Model (with grid adaptation and double pressure)

* The push buttons ❶ and ❷ both have the same lowering function for the pusher plates and knives.

Control functions

- ❶ Raising and lowering the pusher plates *
- ❷ Selection of 10 or 20 divisions/pressing
- ❸ Raising the knives for cleaning
- ❹ Pressing duration timer
- ❺ With/without grid selection
- ❻ Raising and lowering the pusher plates *
- ❼ Pressure selection (Soft Dough)
- ❽ Master switch



With the use of a grid :

For safety reasons during its use, buttons ❶ and ❷ must be pressed simultaneously to allow the pusher plates to rise.

- In 40 divisions: 100 g
- In 80 divisions: 50 g

Operating comfort

■■■ The locking of the lid starts the cycle

■ Step 1 :

The baker closes the lid manually. Mechanical assistance saves effort



■ Step 2 :

Locking is done automatically by simple pressure and avoids any "forced" movements or twisting of the wrist.

■ Step 3 :

Locking the lid initiates the start of dough equalisation in the bowl (adjustable on the control panel) at the end of which the knives will rise. The pressing and division cycles then start automatically.

■ Step 4 :

Unlocking is done automatically at the end of the cycle, releasing the lid. However, it does not rise automatically so as to avoid exposing the dough if the baker is not ready to deal with it.

■ Step 5 :

The lid is raised by the user when he decides. Opening is also assisted to avoid tiredness due to repeated effort. The pusher plate rises to give access to the cut dough pieces.

Structure of Divimach

- 1 Chrome bar for closing the lid and protecting the front of the machine .
- 2 Internal surface of the lid in high performance food-grade, non-stick industrial plastic:
 - Avoids sticking, promotes even distribution of the dough
 - Absorbs impact and noise when the lid is closed
 - Reduces flour dusting
- 3 Stainless steel dough compartment and bevelled knives for a perfect cut.
- 4 Lining of the dough compartment edge and uprights of the stainless steel body for easy maintenance and food contact.
- 5 Easily removable cover plates, facilitating maintenance.
- 6 Balancing of the lid with springs located outside the splash zones.
- 7 Multi-directional castors with locking at the front, for easy moving of the machine.
- 8 An oversized hydraulic unit for silent operation and intensive use.
- 9 Control panel (see description on the previous page)
- 10 Easily interchangeable insert grid
- 11 Flour dust recovery drawer



« AGP » model

Health and safety

Easy cleaning

The rear and side cover plates can be easily removed for easy maintenance inside the machine.

The cylinder gives separate control of the knives and pusher plates to make cleaning easier. A push button is used to remove the knives at the end of operation. This allows for meticulous cleaning between the bottom plate base as well as the lubrication of blades for good maintenance.

The absence of a return spring and multiple guide pins in which dirt can accumulate is also an important feature.

The removal of the pusher plates is straight forward, with just 4 transverse retaining pins (see photo above).



A well thought-out selection of materials

- The dough compartment and knives are in food-grade stainless steel
- The knife-holder trays are made of anti-corrosion steel
- The pusher plates trays are made of aluminium

Divimach: When versatility and simplicity coincide...

Loading
dough



10 divisions



20 divisions



40 divisions



80 divisions



8 pieces
513 x 50 mm



40 triangles



Division with knives



400 g to 2000 g / 200 g to 1000 g

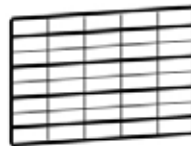

Division with grid



100 g to 200 g

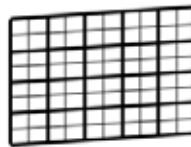

Division with grid



50 g to 100 g



Division with grid



250 g to 400 g

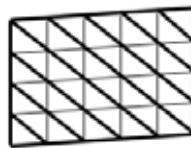

Division with grid



100 g to 200 g

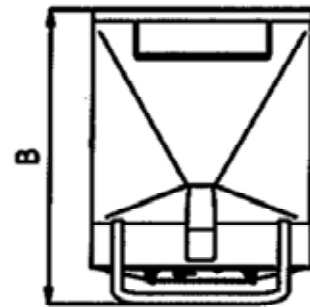
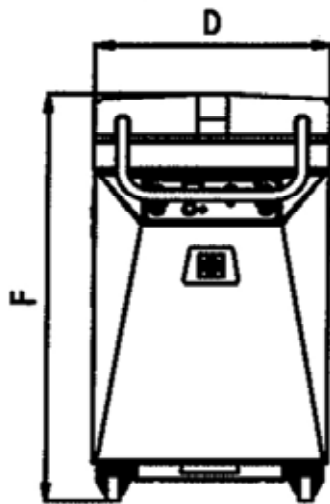
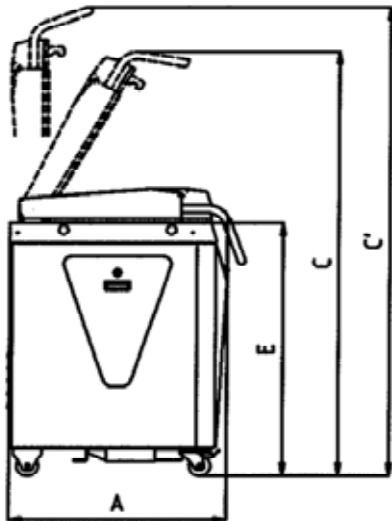

Models *

Reference	Model
0H000202	A model - Divimach in standard version
0H000212	AG model - Divimach with grid adaptation
0H000222	AP model - Divimach with double pressure
0H000232	AGP model - Divimach with grid adaptation and double pressure

* The Divimach can be optionally equipped with a selector to regulate the pressure for hard dough or soft dough. This upgrade from model A to model AP can be done afterwards, without return to the factory.

Grids

Reference	Model
3H001103	Grid - 40 divisions 100 x 50 mm
3H001104	Grid - 80 divisions 50 x 50 mm
3H001105	Grid - 40 triangles B = 100 mm x H = 100 mm
3H001106	Grid - 6 pieces 166 x 200 mm*
3H001107	Grid - 6 pieces 513 x 65 mm*
3H001108	Grid - 16 pieces 62 x 200 mm*
3H001109	Grid - 8 pieces 513 x 50 mm*
3H001110	Grille 20 + 40 divisions
3H001111	Grid - 10 pieces 49 x 410 mm*

* For fermented dough

Technical features (indicative values)

Model	A	AP	AG	AGP
Number of divisions		10 / 20 divisions		
Bowl depth		140 mm		
Bowl size		513 x 410 mm		
Weight of dough pieces		400 / 2000 g (10 divisions) and 200 / 1000 g (20 divisions)		
Non-stick pusher plate dimensions		100 x 100 mm		
Dough capacity : minimum		4 Kg		
Dough capacity : maximum		20 Kg		
Hourly output		900 - 1250 P/h		
Loading height (E)		1020 mm		
Overall (A x B x F)		630 x 890 x 1150 mm		
Height lid raised - intermediate position (C)		1700 mm		
Height lid raised - grid position (C')		1880 mm		
Footprint (A x D)		630 x 820 mm		
Net weight		380 kg		
Soft Dough	No	Yes	No	Yes
Grid adaptation	No	No	Yes	Yes
Power		1,8 kW		
Power supply (other power supply on demand)		400 V 3PH + N 50 Hz		

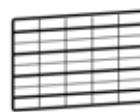

3H001103

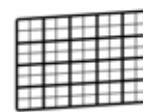

3H001104

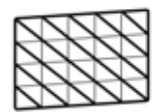

3H001105

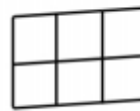

3H001106

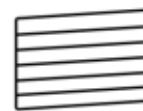

3H001107



3H001108

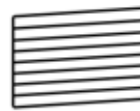

3H001109

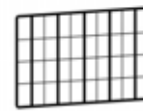

3H001110

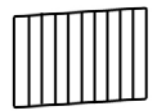

3H001111



BONGARD

BP 17 Holtzheim — F-67843 Tanneries Cedex - France
 Tel : +33 3 88 78 00 23 - Fax : +33 3 88 76 19 18
 www.bongard.fr - bongard@bongard.fr

Machine complies to the standards CE