



PRODUCT ADVANTAGES

- Compact glasswasher: with an installation height of only 850mm (including 150mm adjustable legs) ideal for narrow places.
- Above average usable chamber height of 315mm for easy loading of extra high glassware / jugs
- Simple to use single button control: provides colour coded machine status
- 3 selectable wash cycles - 60, 120 & 180 seconds + a special cutlery cycle & the Hygiene programme (in combination with Hygiene-Tab INTENSIV) for removal of calcium carbonate and other deposits from wash chamber
- Amazingly low 1.8 l of rinsing water per cycle
- Rinse pressure pump to overcome fluctuating or low supply water pressures and to provide guaranteed consistent wash results. Suitable for use with HOBART RO-S reverse osmosis water treatment
- Deep drawn low volume wash tank with integral strainer
- Double walled and insulated cabinet and door for low noise and heat emission during operation
- USB-interface: download of operational data via
- Optional refill signal: monitors contents of external as well as integrated chemical containers
- Supplied with 1 x 396x396mm rack and grid shelf to support racks up to 400x400mm, fill and drain hoses, chemical pumps, 15amp single phase plug and lead for ease of installation
- Designed and manufactured in GERMANY by HOBART
- WATERMARK approved

TECHNICAL DATA

Cycle times*	1. 60sec 2. 120sec 3. 180sec Special cutlery cycle Hygiene Cycle
Water consumption	1.8 l/rack
Tank capacity	8 litres
Tank heating	0.8 kW
Power supply	240 / 50 / 1
Booster loading Standard	2.8 kW
Total loading Standard	3.2 kW 15A
Wash pump	0.4 kW 160 l/min
Rack size	400 x 400 mm
Loading height	315 mm
Noise level	62 dB (A)
Weight (gross / net)	61 / 47 kg

*Supplied with 150mm adjustable legs

*Thermostop guarantees required temperatures with cold water and / or 240 V connection, the actual cycle times extend accordingly.

For machine protection the water hardness should not exceed 3°dH, if higher we recommend using an integrated water softener or an external water softener of the product line HYDROLINE PROTECT.

DIMENSIONAL DRAWING

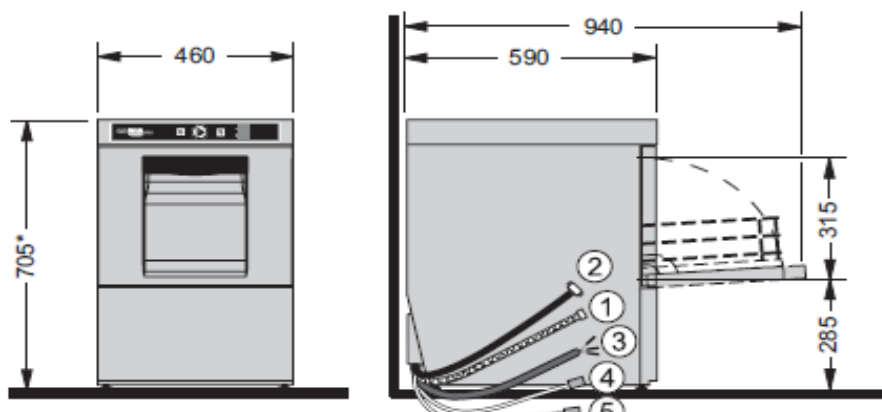

* + 150mm adjustable legs



CONNECTIONS

① Drain hose	2,000 mm ID20/OD25
② Supply hose	2,000 mm R 3/4"
Reverse Osmosis unit (RO-S)	Independent gravity waste to tundish
Required flow rate	5 l/min
Flow pressure	0.5 (0.8 with softener)-6 bar
Max. supply water temperature	60 °C G415 35 °C with RO-S
③ Power cord	2,000 mm
Supply hose for	
④ Detergent	2,500 mm
⑤ Rinse aid	2,500 mm