

50Hz

iT0450 Ice Cube Machine

iT0450 Ice Cube Machine

Models

- IDT0450A IYT0450A IDT0450W



Indigo NXT Series iT0450 Ice Machine on D400 Bin

Designed for operators who know that ice is critical to their business, the Indigo NXT Series ice machine's preventative diagnostics continually monitor itself for reliable ice production. Improvements in cleanability and programmability make your ice machine easy to own and less expensive to operate.

- **New levels of Performance** – Showcasing an average of 9% lower energy consumption, up to 12% increase in ice production and a 19% reduction in condenser water usage and a 5% reduction in potable water usage. This translates into lower cost of ownership over the life of your machine.
- **easyTouch[®] Display** - New icon based touch screen takes the guess work out of owning and operating an ice machine.
- **Multiple Language Capability** - The easyTouch display is available in multiple languages selected in the initial start-up installation Wizard.
- **Programmable Ice Production** – Now its super easy to program your ice machine to be off at certain times of the day to save money with fluctuating electrical rates. Also programmable by daily ice production volume.
- **Easy to Clean Foodzone** – Hinge front door swing out for easy access. Removable water-trough, distribution tube, curtain, water probe and water pump for fast and efficient cleaning. Selected components are made with AlphaSan[®] antimicrobial.
- **Intelligent Diagnostics** – Provides 24 hour preventative maintenance and diagnostic feedback for trouble free operation.
- **Acoustical Ice Sensing Probe** – Unique patented technology allows for reliable operation in challenging water conditions and environments
- Available **LuminIce[®] II Growth Inhibitor** – Controls the growth of bacteria and yeast within the Food zone keeping the machine cleaner longer. A new indicator in the display keeps you abreast of the operational status.

Ice Machine Electric

230/ 50/ 1

Minimum circuit ampacity:

Air-cooled: 5.6 amps
Water-cooled: 5.3 amps

Maximum fuse size:

Air Cooled: 15 amps
Water cooled 15 amps



Specifications

Operating Limits:

BTU Per Hour:
3,800 (average),
and 6,000 (peak)

Refrigerant:

R410A CFS - Free
Lowers global warming
by 48%

- Ambient Temperature Range: 40° to 110°F (4.4° to 43.3° C)
Water Temperature Range: 40° to 90°F (4.4° to 32.2° C)
- Water Pressure Ice Maker Water In:
Min. 20 psi (137.9 kPa)
Max. 80 psi (551.1 kPa)

Ice Shape



Half Dice
3/8" x 1 1/8" x 7/8"
(.95 x 2.86 x 2.22 cm)
Cube weight 5.7 g



Dice
7/8" x 7/8" x 7/8"
(2.22 x 2.22 x 2.22 cm)
Cube weight 8.5 g



COMPANY WITH
QUALITY SYSTEM



50Hz

Indigo[®] NXT™ iT0450 Ice Cube Machine

iT0450 on D-400 Storage Bin

- (A) Electrical Entrance (2) Options
- (B) 3/8" (0.95 cm) F.P.T. Water Condenser Inlet (water-cooled units)
- (C) 1/2" (1.27 cm) F.P.T. Water Condenser Outlet (water-cooled units)
- (D) 1/2" (1.27 cm) Auxillary Base Drain Socket
- (E) 3/8" (0.95 cm) F.P.T. Ice Making Water Inlet
- (F) 1/2" (1.27 cm) F.P.T. Ice Making Water Drain
- (G) 3/4" (1.91 cm) Bin Drain

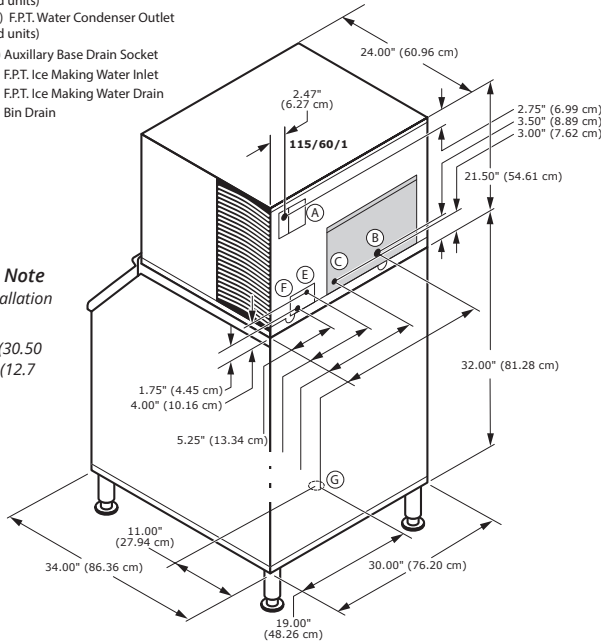

Installation Note
Minimum installation clearance:
Top/side: 12" (30.50 cm)
Back is 5" (12.7 cm)

Space-Saving Design



	iT0450 D-400	iT0450 D-570
Height	59.50" 151.13 cm	71.50" 181.61 cm
Width	30.00" 76.2 cm	30.00" 76.2 cm
Depth	34.00" 86.30 cm	34.00" 86.30 cm
Bin	365 lbs.	543 lbs.
Storage	165.7 kgs.	241.1 kgs.

Height includes adjustable bin legs 6.00" to 8.00", (15.24 to 20.32 cm) set at 6.00" (15.24 cm).
Bin capacity is based on 90% of the volume x 33 lbs/ft³ average density of ice.

Specifications

	Model	Ice Shape	Ice Production 24 Hours		Power Usage kWh 45.4 kg / 100 lbs @ 32°Air / 21°C Water 90°Air / 70°F Water	Potable Water Usage/100 lbs. 45.4 kgs. of Ice
			21°Air / 10°C Water 70°Air / 50°F Water	32°Air / 21°C Water 90°Air / 70°F Water		
AIR COOLED	IDT0450A	dice	440 lbs.	355 lbs.	1 Ph	19 Gal.
			200 kgs	161 kgs		
AIR COOLED	IYT0450A	half-dice	460 lbs.	375 lbs.	5.30	71.9 L
			209 kgs	170 kgs		
WATER COOLED	IDT0450W	dice	420 lbs.	355 lbs.	4.88	19 Gal.
			191 kgs	161 kgs		

* Water-cooled Condenser Water Usage / 100 lbs. /45.4 kgs. Of Ice: 140 gal/ 530 L.

Order separately: Ice storage bin for all units
This product is hermetically sealed and contains fluorinated greenhouse gas R404A

Accessories

LuminIce[®] II Growth Inhibitor
reduces yeast and bacteria growth for a cleaner ice machine.



External Scoop holder

Protect the ice scoop with the NSF approved versatile scoop holder.



Arctic Pure[®] Water Filters

Reduces sediment and chlorine odors for better tasting ice.

