

50Hz

iT1200 Ice Cube Machine

iT1200 Ice Cube Machine

Models

- IDT1200A
 IYT1200A
 IDT1200W
 IYT1200W
 IDT1200N
 IYT1200N



Indigo NXT iT1200 ice machine on a D570 bin

Designed for operators who know that ice is critical to their business, the Indigo NXT Series ice machine's preventative diagnostics continually monitor itself for reliable ice production. Improvements in cleanability and programmability make your ice machine easy to own and less expensive to operate.

- **New levels of Performance** - Showcasing an average of 5% lower energy consumption and a 22% reduction in condenser water usage. This translates into lower cost of ownership over the life of your machine.
- **easyTouch[®] Display** - New icon based touch screen takes the guess work out of owning and operating an ice machine.
- **Multiple Language Capability** - The easyTouch display is available in multiple languages selected in the initial start-up installation Wizard.
- **Programmable Ice Production** - Now its super easy to program your ice machine to be off at certain times of the day to save money with fluctuating electrical rates. Also programmable by daily ice production volume.
- **Easy to Clean Foodzone** - Hinge front door swing out for easy access. Removable water-trough, distribution tube, curtain, water probe and water pump for fast and efficient cleaning. Selected components are made with AlphaSan[®] antimicrobial.
- **Intelligent Diagnostics** - Provides 24 hour preventative maintenance and diagnostic feedback for trouble free operation.
- **Acoustical Ice Sensing Probe** - Unique patented technology allows for reliable operation in challenging water conditions and environments.
- **Available LuminIce[®] II Growth Inhibitor** - Controls the growth of bacteria and yeast within the Food zone keeping the machine cleaner longer. A new indicator in the display keeps you abreast of the operational status.

Ice Machine Electric

230/50/1

Minimum circuit ampacity:

Air-cooled: 14 *1ph*
 Water-cooled: 13.3 *1ph*
 Remote: 15.6 *1ph*

Maximum fuse size:

Air-cooled: 20 *1ph*
 Water-cooled: 20 *1ph*
 Remote: 25 *1ph*



Specifications

BTU Per Hour:
16,200 (average),
and 19,100 (peak)

Refrigerant:
R410A CFS - Free
Lowers global warming
by 48%

Operating Limits:

- Ambient Temperature Range: 40° to 110° F (4.4° to 43.3° C)
Water Temperature Range: 40° to 90° F (4.4° to 32.2° C)
- Water Pressure Ice Maker Water In:
Min. 20 psi (137.9 kPa)
Max. 80 psi (551.1 kPa)

Ice Shape



Half Dice
3/8" x 1 1/8" x 7/8"
(.95 x 2.86 x 2.22 cm)
Cube weight 5.7 g



Dice
7/8" x 7/8" x 7/8"
(2.22 x 2.22 x 2.22 cm)
Cube weight 8.5 g



COMPANY WITH
QUALITY SYSTEM



50Hz

Indigo® NXT™ iT1200 Ice Cube Machine

iT1200 on D-570 Storage Bin

- Ⓐ Electrical Entrance (2) Options
- Ⓑ 3/8" (0.95 cm) F.P.T. Water Condenser Inlet (water-cooled units)
- Ⓒ 1/2" (1.27 cm) F.P.T. Water Condenser Outlet (water-cooled units)
- Ⓓ 1/2" (1.27 cm) Auxillary Base Drain Socket
- Ⓔ 3/8" (0.95 cm) F.P.T. Ice Making Water Inlet
- Ⓕ 1/2" (1.27 cm) F.P.T. Ice Making Water Drain
- Ⓖ 3/4" (1.91 cm) Bin Drain

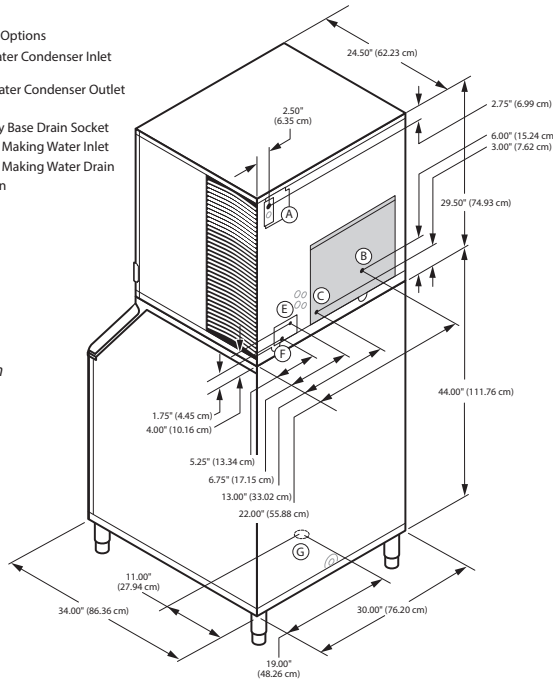

Installation Note
Minimum installation clearance:
Top/side: 12" (30.50 cm)
Back is 5" (12.7 cm)

Space-Saving Design



	iT1200 D-570	iT1200 D-970
Height	79.50"	79.50"
Width	201.93 cm	201.93 cm
Depth	30.00"	48.00"
	76.20 cm	121.92 cm
Bin	34.00"	34.00"
	86.30 cm	86.30 cm
Storage	543 lbs.	882 lbs.
	241.1 kgs.	400.1 kgs.

Height includes adjustable bin legs 6.00" to 8.00" (15.24 to 20.32 cm) set at 6.00" (15.24 cm).
Bin capacity is based on 90% of the volume x 33 lbs/ft³ average density of ice.

* K00458 bin adapter required

Specifications

This product is hermetically sealed and contains fluorinated greenhouse gas R410A

	Model	Ice Shape	Ice Production 24 Hours		Power Usage kWh/45.4 kgs 100 lbs @ 32°Air /21°C Water 90°Air/70°F Water	Potable Water Usage/100 lbs. 45.4 kgs. of Ice
			21°Air / 10°C Water 70°Air/ 50°F Water	32°Air / 21°C water 90°Air/ 70°F Water		
AIR COOLED	IDT1200A	dice	1155 lbs.	945 lbs.	4.80	19.9 Gal.
			524 kgs	429 kgs		75.3 L
	IYT1200A	half-dice	1200 lbs.	935 lbs.	4.75	19.9 Gal. 75.3 L
WATER COOLED	IDT1200W	dice	1090 lbs.	970 lbs.	4.16	19.9 Gal.
			494 kgs	440 kgs		75.3 L
	IYT1200W	half-dice	1105 lbs.	930 lbs.	4.00	19.9 Gal. 75.3 L
* Water-cooled Condenser Water Usage / 100 lbs. /45.4 kgs. Of Ice: 140 gal/ 530 L.						
REMOTE COOLED	IDT1200N	dice	1095 lbs.	950 lbs.	4.10	19.9 Gal.
			497 kgs	431 kgs		75.3 L
	IYT1200N	half-dice	1152 lbs.	996 lbs.	4.10	19.9 Gal. 75.3 L
			523 kgs	452 kgs		

Order Separately ice storage bin for all units, JCT1200 vertical condenser order separately for Remote cooled units

Accessories

LuminIce® II Growth Inhibitor
reduces yeast and bacteria growth for a cleaner ice machine.



External Scoop holder

Protect the ice scoop with the NSF approved versatile scoop holder.

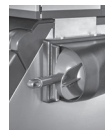

Arctic Pure® Water Filters

Reduces sediment and chlorine odors for better tasting ice.

