

50Hz

# iT1500 Ice Cube Machine

iT1500 Ice Cube Machine

## Models

- IDT1500A     IDT1500W     IDT1500N  
 IYT1500A     IYT1500W     IYT1500N



Indigo NXT Series iT1500 Ice Machine on D970C Bin

Designed for operators who know that ice is critical to their business, the Indigo NXT Series ice machine's preventative diagnostics continually monitor itself for reliable ice production. Improvements in cleanability and programmability make your ice machine easy to own and less expensive to operate.

- **New levels of Performance** - Showcasing an average of 6% lower energy consumption, up to 9% increase in ice production and a 9% reduction in condenser water usage. This translates into lower cost of ownership over the life of your machine.
- **easyTouch<sup>®</sup> Display** - New icon based touch screen takes the guess work out of owning and operating an ice machine.
- **Multiple Language Capability** - The easyTouch display is available in multiple languages selected in the initial start-up installation Wizard.
- **Programmable Ice Production** - Now its super easy to program your ice machine to be off at certain times of the day to save money with fluctuating electrical rates. Also programmable by daily ice production volume.
- **Easy to Clean Foodzone** - Easy Access front door panel. Removable water-trough, distribution tube, curtain, and sensing probes for fast and efficient cleaning. Select components made with AlphaSan<sup>®</sup> antimicrobial.
- **Intelligent Diagnostics** - Provides 24 hour preventative maintenance and diagnostic feedback for trouble free operation.
- **Acoustical Ice Sensing Probe** - Unique patented technology allows for reliable operation in challenging water conditions and environments.
- Available **LuminIce<sup>®</sup> II Growth Inhibitor** - Controls the growth of bacteria and yeast within the Food zone keeping the machine cleaner longer. A new indicator in the display keeps you abreast of the operational status.

## Ice Machine Electric

230/50/1

### Minimum circuit ampacity:

Air-cooled: 14.9 *1ph*  
 Water-cooled: 14.2 *1ph*  
 Remote-cooled: 15.2 *1ph*

### Maximum fuse size:

Air-cooled: 25 *1ph*  
 Water-cooled: 25 *1ph*  
 Remote-cooled: 25 *1ph*



## Specifications

### Operating Limits:

**BTU Per Hour:**  
 23,000 (average),  
 and 27,000 (peak)

### Refrigerant:

R-410 CFC-free

- Ambient Temperature Range: 40° to 110°F (4.4° to 43.3° C)  
 Water Temperature Range: 40° to 90°F (4.4° to 32.2° C)
- Water Pressure Ice Maker Water In:  
 Min. 20 psi (137.9 kPa)  
 Max. 80 psi (551.1 kPa)

## Ice Shape



**Half Dice**  
 3/8" x 1 1/8" x 7/8"  
 (.95 x 2.86 x 2.22 cm)  
 Cube weight 5.7 g



**Dice**  
 7/8" x 7/8" x 7/8"  
 (2.22 x 2.22 x 2.22 cm)  
 Cube weight 8.5 g



**Regular**  
 1 1/8" x 1 1/8" x 7/8"  
 (2.86 x 2.86 x 2.22 cm)  
 Cube weight 14.2 g



COMPANY WITH  
 QUALITY SYSTEM



# 50Hz

# Indigo<sup>®</sup> NXT™ iT1500 Ice Cube Machine

## iT1500 on D970C Storage Bin

- Ⓐ Electrical Entrance (2) Options
- Ⓑ 1/2" (1.27 cm) F.P.T. Water Condenser Outlet (water-cooled units)
- Ⓒ 3/8" (0.95 cm) F.P.T. Water Condenser Inlet (water-cooled units)
- Ⓓ 3/8" (0.95 cm) F.P.T. Ice Making Water Inlet
- Ⓔ 1/2" (1.27 cm) F.P.T. Ice Making Water Drain
- Ⓕ 1/2" (1.27 cm) Auxillary Base Drain Socket
- Ⓖ 3/4" (1.91 cm) Bin Drain

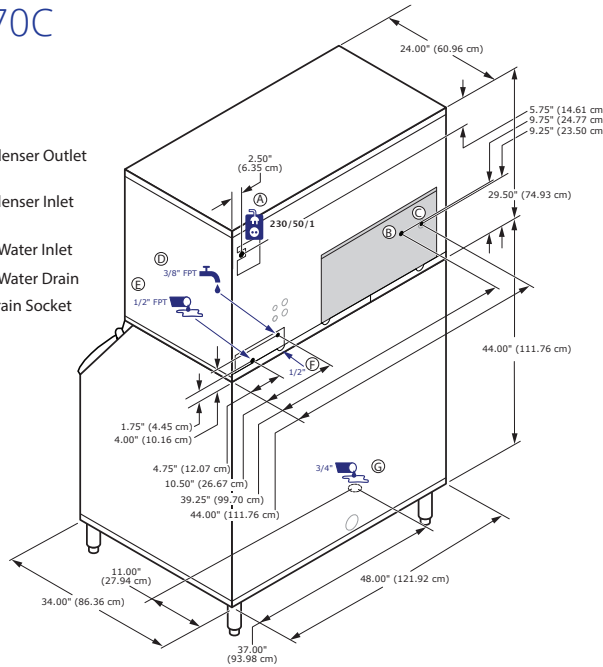

### Installation Note

Air Cooled clearance:

- Top: 24" (61.0 cm)
- Sides: 24" (61.0 cm)
- Back: 5" (30.5 cm)

Water Cooled clearance:

- Top/Sides: 8" (20.3 cm)
- Back: 5" (12.7 cm)

## Space-Saving Design



	iT1500 D970C
Height	79.50" / 201.90 cm
Width	48.00" / 121.92 cm
Depth	34.00" / 86.30 cm
Bin Storage	710lbs / 322.2 kgs

Height includes adjustable bin legs 6.00" to 8.00", (15.24 to 20.32 cm) set at 6.00" (15.24 cm).

## Specifications

	Model	Ice Shape	Ice Production 24 Hours		Power Usage kWh 45.4 kg / 100 lbs @ 32°Air / 21°C Water 90°Air / 70°F Water	Potable Water Usage/100 lbs. 45.4 kgs. of Ice
			21°Air / 10°C Water 70°Air / 50°F Water	32°Air / 21°C Water 90°Air / 70°F Water		
AIR-COOLED	IDT1500A	dice	1,725 lbs.	1,265 lbs.	1 Ph	20 Gal.
			782 kgs	574 kgs		
AIR-COOLED	IYT1500A	half-dice	1,725 lbs.	1,350 lbs.	4.45	20 Gal.
			782 kgs	612 kgs		
WATER-COOLED	IDT1500W	dice	1,650 lbs.	1,410 lbs.	3.27	20 Gal.
			748 kgs	640 kgs		
WATER-COOLED	IYT1500W	half-dice	1,655 lbs.	1,375 lbs.	3.50	20 Gal.
			751 kgs	624 kgs		
* Water-cooled Condenser Water Usage / 100 lbs. /45.4 kgs. Of Ice: 140 gal./ 530 L.						
REMOTE-COOLED	IDT1500N	dice	1,650 lbs.	1,375 lbs.	3.90	20 Gal.
			748 kgs	624 kgs		
REMOTE-COOLED	IYT1500N	half-dice	1,700 lbs.	1,400 lbs.	3.90	20 Gal.
			771 kgs.	636 kgs		

Order separately: Ice storage bin for all units, line-set and remote condenser unit JCT1500 for remote cooled units.  
This product is hermetically sealed and contains fluorinated greenhouse gas R404A

## Accessories

**LuminIce<sup>®</sup> II Growth Inhibitor**  
reduces yeast and bacteria growth for a cleaner ice machine.



### External Scoop holder

Protect the ice scoop with the NSF approved versatile scoop holder.

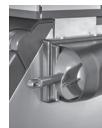

### Arctic Pure<sup>®</sup> Water Filters

Reduces sediment and chlorine odors for better tasting ice.



©2021 Manitowoc. Continuing product improvement may necessitate change of specifications without notice.