

Project :	
Model # :	
Item # :	Qty :
Available W/H :	
Approval :	

Undercounter Refrigerator

Side Mount Undercounters
 K Series

Model : KUR9-1-N



≡ FEATURES & BENEFITS ≡

- **Digital temperature control & monitor system**
 Keep food products safe by maintaining constant temperatures. External digital display allows for easy monitoring.
- **Efficient refrigeration system**
 Turbo Air's K series solid door refrigerators are designed with oversized and balanced (CFC Free R-290) refrigeration systems. These include efficient evaporators and condensers for faster cooling and greater efficiency.
- **Side mount compressor unit (Front Breathing)**
 With compressors positioned on the side of the unit, our refrigerators can now be serviced without being moved. Our innovative, front breathing feature also allows this model to be highly efficient in narrow spaces.
- **Exterior & interior of the cabinet**
 The Turbo Air K series boasts a stainless steel exterior (galvanized steel back and bottom). Interior is stainless steel floor with AL sides, back and AL door liners. It guarantees the utmost in cleanliness and long product life. The K series adds a touch of style to the most refined setting.
- **Hot gas condensate system**
 Through Turbo Air's creative innovation, the condensate system surfaces have been specially treated to resist corrosion. This not only increases efficiency without the risk of refrigerant leakage from corrosion, but also thoroughly prevents the overflow of condensate water.
- **Adjustable, heavy duty, PE (polyethylene) coated wire shelves**
- **LED interior lighting system**
 Brighter and longer lasting LED lights provide attractive, enhanced illumination compared to fluorescents. It saves energy by producing less heat, while maximizing the visibility.
- **High-density polyurethane insulation**
 The entire cabinet structure and solid doors are foamed-in-place using high density, CFC free polyurethane insulation.
- **Ergonomically designed doors**
 Customers' fatigue fades away with easy grip handles and doors that open effortlessly. These features along with self-closing doors make this the ultimate choice in customer convenience.
- **Magnetic door gaskets**
 Magnetic door gaskets are of one-piece construction, removable without tools for ease of cleaning and replacement.
- **Easy open front grille with condenser cleaning brush kit**
 Front grille cover is easily removable without any tools, which makes condenser cleaning easy and convenient at any time. Handy condenser cleaning brush is included inside the front grille cover.
- **Refrigerator holds 1°C ~ 8°C for the best in food preservation**

Model	Swing Doors	Capacity (Liters)	#of Shelves	HP	AMPS	Crated Weight (kg.)	L x D* x H† (mm)
KUR9-1-N	1	198	1	1/4	2.3	86	900 x 700 x 730

* Depth does not include 1"(25mm) for rear spacers. † Height does not include 5"(127mm) for caster height.

Model : KUR9-1-N

ELECTRICAL DATA	
Voltage	220~240V/50Hz/1ph
Plug Type	※
Full Load Amperes	2.3
Compressor HP	1/4
Cord Length (meter)	2.8
Refrigerant	R-290
DIMENSIONAL DATA	
Net Capacity (liters)	198
Ext. Length Overall (in.)	35 3/8 (900mm)
Ext. Depth Overall (in.) *	27 1/2 (700mm)
Ext. Height Overall (in.) †	28 3/4 (730mm)
# of Doors	1
# of Shelves	1
Shelf Size (L x D) (mm)	489 x 505
Net Weight (KG)	72
Gross Weight (KG)	86

Design and specifications subject to change without notice.

Actual shipping weight may differ due to extra packing materials for product protection.

* Depth does not include 1"(25mm) for rear spacers.

† Height does not include 5"(127mm) for caster height.

※ Plug type may vary per each country's requirement

- Anti-corrosion coated evaporator
- Self-contained system
- Standard 4" dia. swivel casters with locks on the front set
- Door locks standard
- Legs available for all models (110mm or 70mm)

PLAN VIEW

unit : inch(mm)

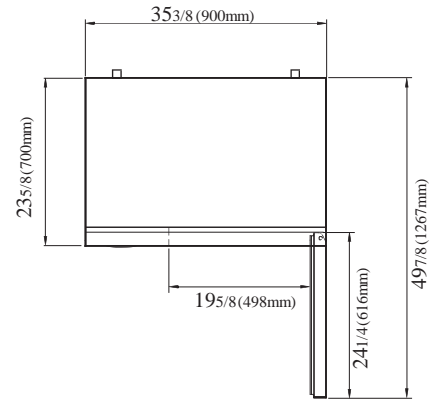

PLAN VIEW

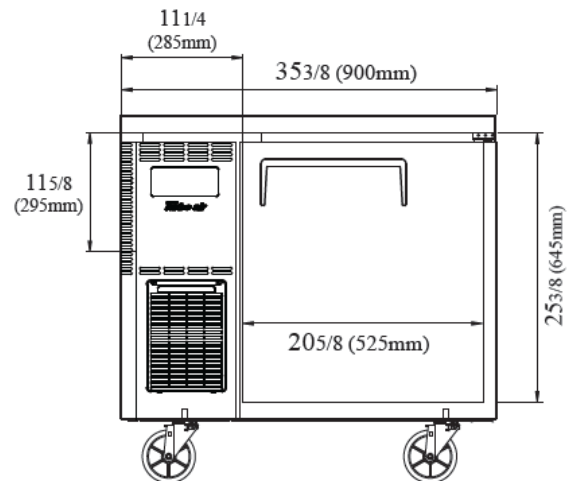

FRONT VIEW

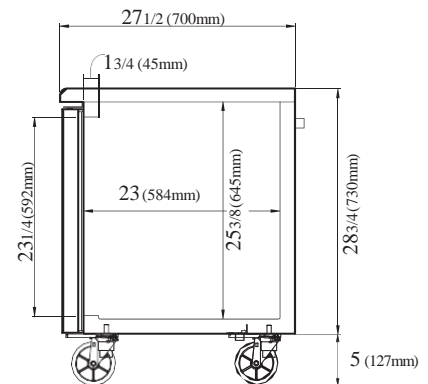

SIDE VIEW