

Dispenser: 02.1533.NC DFR 280 heated
heating element 230V-400W

Crockery:

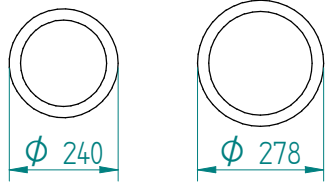

from $\phi 240$ to $\phi 278$

Dimensions: weight (empty): 10 kg

A = flange

E = cut out

H = build in height

S = effective stacking height

y x z = cut out operating panel



EN

VR :

IR :

MOBILE CONTAINING

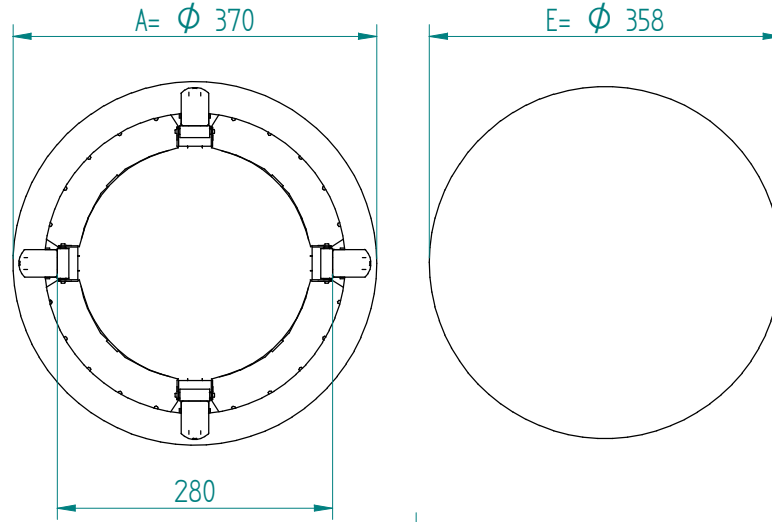

options, order separate;
pc cover: 91.5030

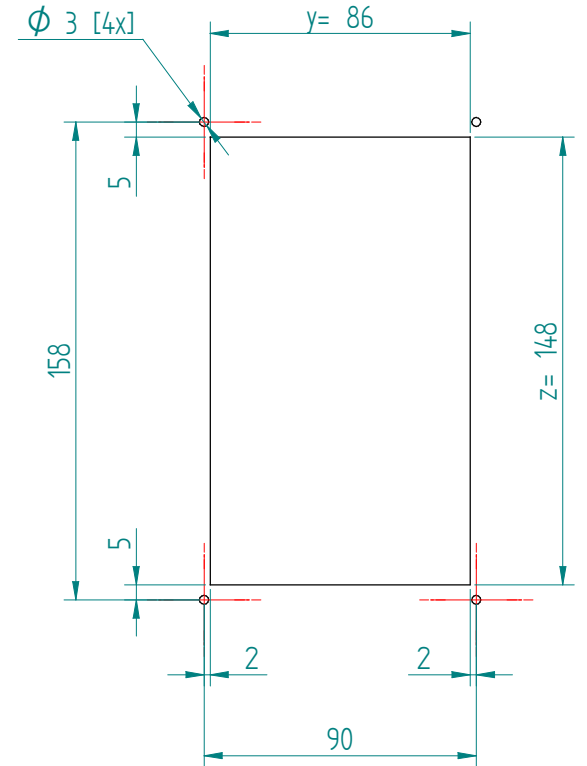
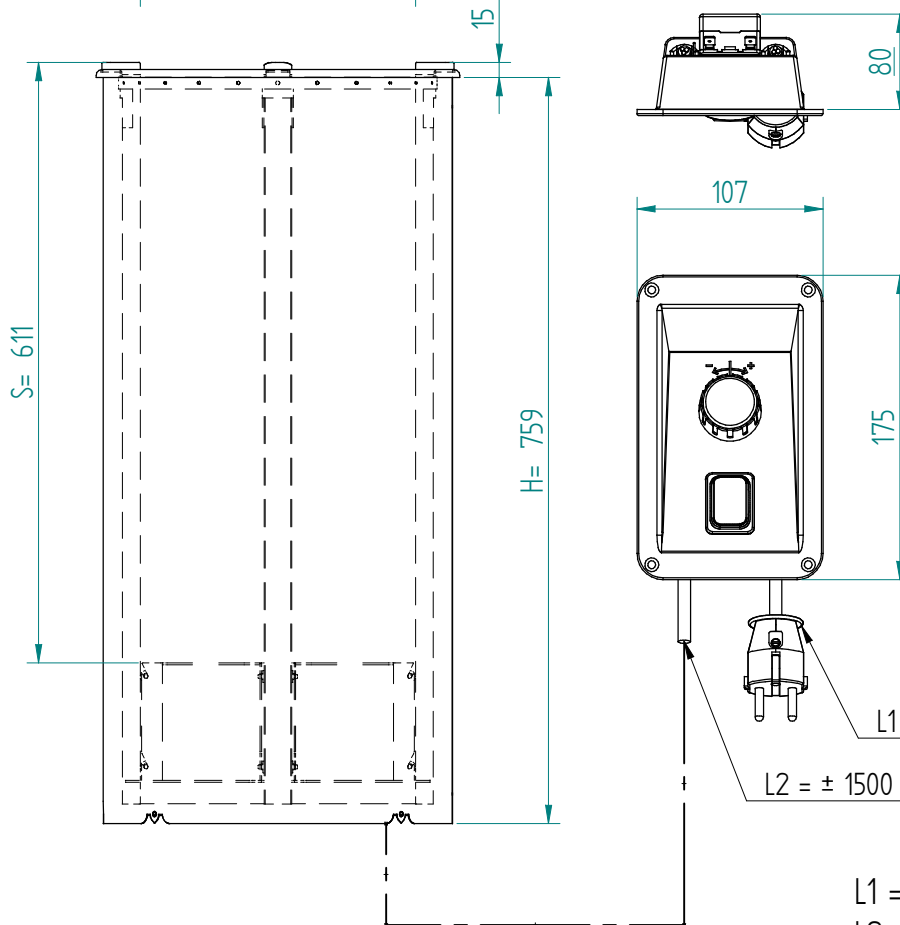
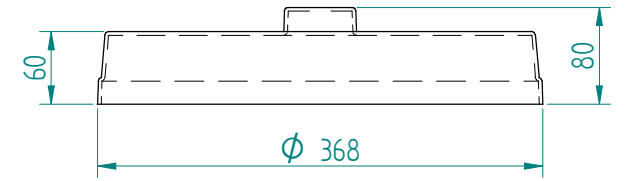

L1 = length cable with plug

L2 = length cable between tube and operating panel