

Bonn

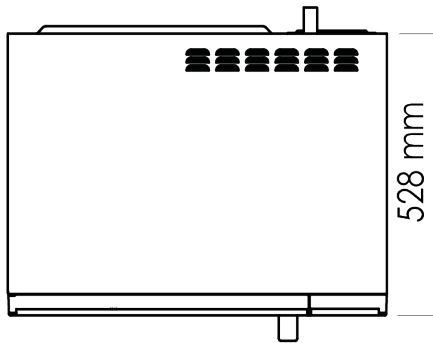

TOP VIEW

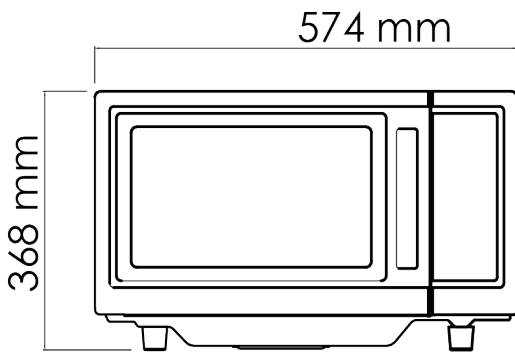

FRONT VIEW

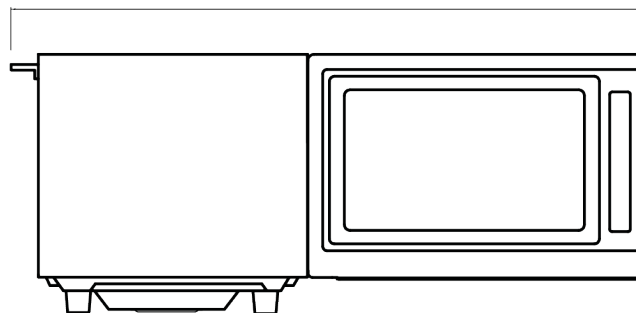

SIDE VIEW (door open)

DIMENSIONS

| | |
|-------------|-----------------------|
| Overall | 574W x 528D x 368H mm |
| Internal | 350W x 400D x 220H mm |
| Net Weight | 32kg |
| Ship Weight | 35kg |

SPECIFICATIONS - Function Type

| | |
|----------------|------------------------------------------------|
| Construction | Stainless Steel |
| Dual Magnetron | Yes |
| Power Source | 3.2 kW, 230v 15Amp, Microwave output 2.1 kW |

STANDARD FEATURES

This sleek and easy to use Bonn G Series commercial microwave is ideal for any establishment. With an easy to clean and convenient digital touch-pad control, it guarantees top-notch performance at the push of a button.

- 2100 Watts of Cooking Power
- Spacious 34L Capacity
- Digital Touch-Pad Controls with LED Lighted Display
- 10 Programmable Memory Functions
- 100 Program Menu Settings
- 4 Stages of Cooking
- 60 Minute Maximum Cook Time
- Commercial Grade Performance
- Made for Continuous Operation
- Stainless Steel Body & Cavity
- Heavy Duty Metal Handle
- Durable Interlock System