

Bonn

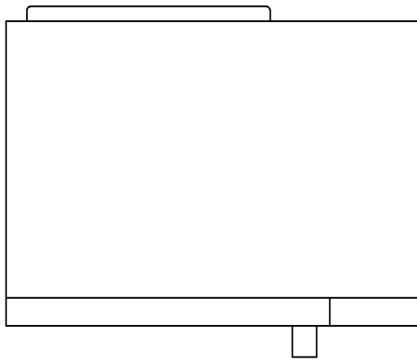

TOP VIEW

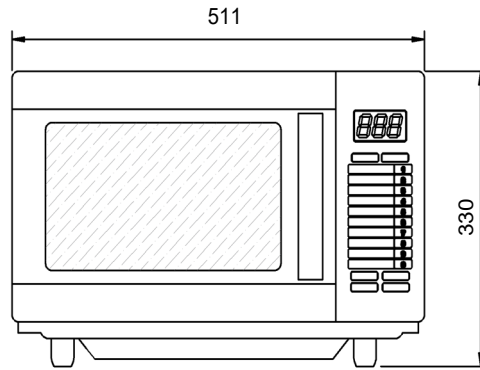

FRONT VIEW

NTS

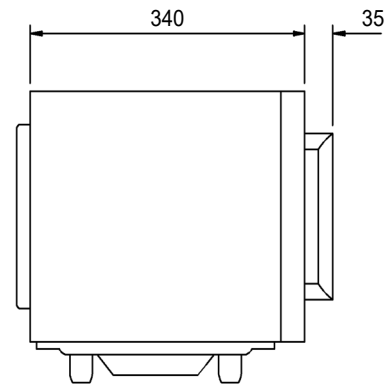

SIDE VIEW

DIMENSIONS

Cavity	330W x 330D x 212H mm
Unit	510W x 382D x 330H mm
Packaging	590W x 465D x 395H mm
Net Weight	17.5kg
Ship Weight	21kg

SPECIFICATIONS - Function Type

Construction	Stainless Steel Interior with Ceramic Base
	Stainless Steel Outer Construction
Power Consumption	1580W
Output Power	1000W
Power Source	240v 10amp

STANDARD FEATURES

- 1000 Watts of Cooking Power
- 25L Capacity
- Digital Touch-Pad Controls with LED Lighted Display
- 10 Programmable Memory Functions
- 4 Power Levels
- 3 Stage Cooking Function
- Touch control
- Double Glass Door with Metallic Handle
- Motorised Stirrer Fan
- Easy Clean Ceramic
- Warranty: Back to Base 24 months parts and 13 months labour