

SPARES

Spare parts are listed below. For parts not listed please include model and serial numbers with a description of the part.

Description	Part Number
Element - 2.4kW	021363
Element - 3.6kW	022627
Thermostat	024159
Over Temperature Cut-Out	233979
Indicator Light - Red	013528
Indicator Light - Amber	024160
Basket	021284
Thermostat Knob	021361
Lid Assembly	SA1661
Sediment Tray	021383
Tank	021319

CIRCUIT DIAGRAM EC61, EC63 (EC62, EC64 per tank)

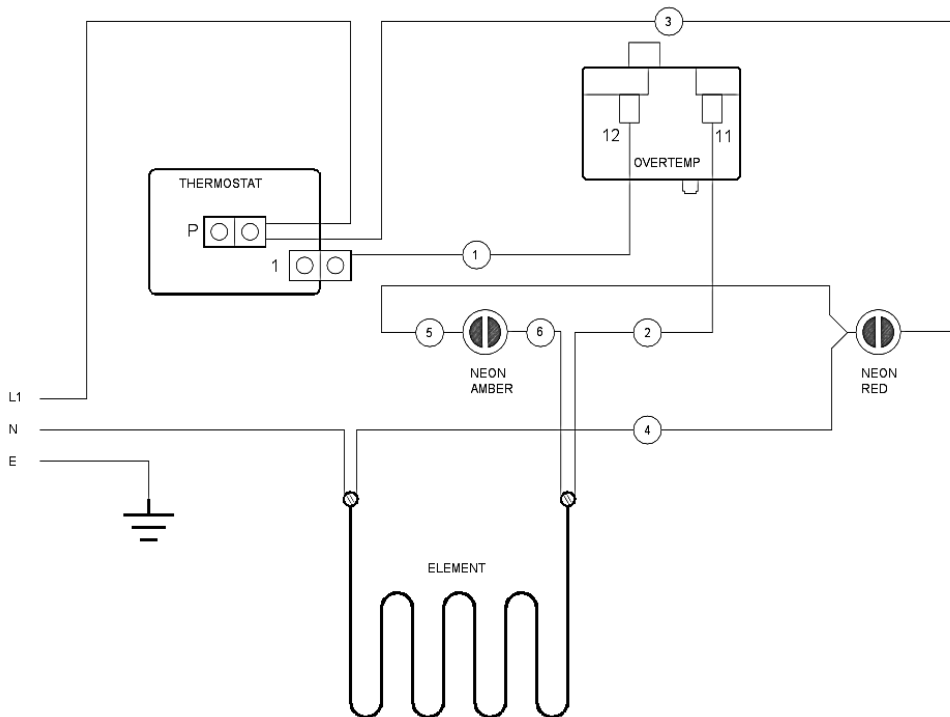

**COUNTERLINE
FRYER**

**MODEL EC61, EC63
MODEL EC62, EC64**

**SINGLE TANK
TWIN TANKS**

INDEX

INSTALLATION	PAGE 1
OPERATION	PAGE 2
SERVICING + SPARES	PAGE 3,4

INSTALLATION

All appliances are to be installed by an electrician who must check the unit is operating correctly. This appliance must be Grounded (Earthed). All installations are to be in accordance with local Health, Safety, and Electrical requirements. A suitable plug is to be fitted according to the power requirements listed below (if not supplied fitted). Each unit should be provided with its own wall mounted isolation switch. The switch should NOT be located above the tank, but accessible in case of fire.

EC61 for 220-240Volts AC, 10 Amps, 2.4KW @ 240V.
 EC62 for 220-240Volts AC, 10 Amps, 2.4KW @ 240V (Per Tank).
 EC63 for 220-240Volts AC, 15 Amps, 3.6KW @ 240V.
 EC64 for 220-240Volts AC, 15 Amps, 3.6KW @ 240V (Per Tank).

WARNING:

BECAUSE FRYERS ARE USED IN EXTREMELY ARDUOUS ENVIRONMENTS, NO MANUFACTURER, EVEN AFTER TAKING EVERY POSSIBLE PRECAUTION, CAN GUARANTEE THE OPERATION OF THE EQUIPMENT TO BE 100% INFALLIBLE.

Great care must be taken by the operator to use the equipment safely, to make sure it is regularly serviced, and in every possible way to guard against the risk of fire.

- A fire extinguisher should be kept in a readily accessible position. We are advised that a 5lb (2kg) Dry Powder is a minimum size.
- A fryer must NOT be switched on and left unattended.
- The fryer must be checked by a competent serviceman regularly.

ALWAYS DISCONNECT FROM POWER SUPPLY BEFORE REMOVING ELEMENT ASSEMBLY FROM TANK

GENERAL

This unit is constructed of stainless steel and due to the removable splashback, element assembly is easy to clean. Removing the elements allows easy obstruction-free access when cleaning the inside of the tank.

Always switch 'Off' power and disconnect supply before taking elements out of the tank.

A removable basket support covers the elements, serving the purpose of supporting the baskets, protecting the elements from damage, and preventing fish, etc, sticking to the element when not using a basket. Inside the back of the tank there is a support on which the fryer baskets may be hooked to allow excess fat to be drained from the chips or fish after cooking. The fat drained off is returned directly to the tank.

OPERATION

This unit is designed for deep frying food in oils or fats. A separate thermostat controls each tank. The red indicator light indicates when the power to the unit is 'On'. **DO NOT remove element assembly from the tank if light is 'On'**. The amber indicator light is a heating indicator. The amber light is 'On' when the element is heating, and 'Off' when the fryer is up to temperature.

Filling Tank: Maximum and minimum fill level marks are provided on the rear of the tank. Maximum is for hot oil / fat, minimum is for cold oil / fat.

WARNING

DANGER OF FIRE EXISTS IF THE OIL LEVEL IS BELOW THE MINIMUM MARK.

DO NOT USE OLD OIL AS IT WILL HAVE A REDUCED FLASH-POINT AND IS MORE PRONE TO SURGE BOILING.

Solid Fats: Remove the element cover and pack fat around and over the elements. Elements should be fully covered. Set the thermostat to 80°C (175°F). If over night the fat solidifies around the element in the tank, re-melt the fat slowly at 80°C (175°F). When fat has melted, set the thermostat to the desired temperature, normally between 180°C and 190°C (360°F-375°F). Do not over fill the tank, and always drain water from baskets of wet chips etc before they are carefully lowered into the oil or fat. This will reduce foaming and reduce the risk of spillovers.

DO NOT operate the fryer until the elements are immersed in the oil or fat. Failure to observe this precaution can result in damage to the elements or risk of fire.

MAXIMUM BATCH SIZE 0.5Kg PER BASKET

The life of the cooking medium can be considerably prolonged if the tank is drained every night and filtered through a fine mesh to remove the small particles of foreign matter. If not filtered, the oil or fat will break down rapidly, and considerably shorten its effective life.

NOTE - Setting the thermostat to maximum will NOT shorten heat up time, but may shorten the life of the oil.
- With the thermostat at the minimum setting, the element and amber heating indicator may still come on briefly when the power to the fryer is switched on if the fryer has been left overnight or longer in an excessively cold room. This is normal operation and the heating indicator will shortly go off again once the oil has been warmed slightly.

CAUTION - EMPTYING THE TANK

For reasons of safety and convenience, DO NOT try to lift a full tank of oil out of the fryer. Remove most of the oil by ladle or pump first. **Turn the power 'Off' and disconnect from power supply at wall** before lifting elements out of tank, pour out remaining oil, and the tank can now be cleaned.

The power supply must remain disconnected from wall at all times when tank is empty or removed.

NOTE - The over temperature cut-out is pre-set to operate at approximately 220°C (450°F). When this control operates, there is a fault that must be serviced. To reset the cut-out, cool the oil and press the cut-out reset button (accessed through the back of the splashback).

DISCONNECT POWER SUPPLY BEFORE RESETTING OVERTEMP

SERVICING

DISCONNECT POWER SUPPLY BEFORE SERVICING

Lift out element/splashback. Remove base of splashback (2 screws from back, 1 from underside).

Elements: Unscrew the wires from the element tails. Remove the capillary clips and the bulb clamps from the element. Remove the two nuts securing the element to the splashback front. Pull element straight out of the splashback. Fit new element, nuts, wires, capillary clips and bulb clamps.

Thermostat or Over Temperature Thermostat: Disconnect the wiring to the thermostat. Pull off the knob (fryer thermostat only) and undo thermostat from splashback (2 screws under knob or at rear). Remove the appropriate capillary clips and bulb clamp from the element. Undo the gland nut completely (inside the splashback). Undo gland retaining nut and remove gland from splashback. Withdraw the capillary and bulb through the gland. Fit new thermostat in reverse order, ensuring that excess capillary is coiled and cable tied inside the splashback to prevent shorting out against electrical connections.

Indicator Light: Remove wires. Squeeze tabs and push out. Fit replacement in same manner and re-attach wires.