

# Convotherm maxx pro easyDial Combi Steamer

## CXESD6.10 ELECTRIC DIRECT STEAM 7 x 1/1 GN

- Direct steam system
- Natural Smart Climate™ (ACS+) cooking methods: Steam, Combi-steam, Convection
- Natural Smart Climate™ extra functions:
  - Crisp&Tasty - 5 moisture removal settings
  - BakePro - 5 levels of traditional baking
  - HumidityPro - 5 humidity settings
  - Controllable fan - 5 speed settings
- easyDial: all functions are set on one operating level
- ConvoClean fully automatic cleaning system
- HygieniCare
- USB port integrated in the control panel
- TriColor indicator ring - indicates the current operating status
- Steam generated by injecting water into the oven chamber
- LED lighting in oven cavity
- Triple glass appliance door
- Right-hinged appliance door



### Standard Features

- Cooking methods:
  - Steam (30-130°C) with guaranteed steam saturation
  - Combi-steam (30-250 °C) with automatic moisture control
  - Convection (30-250 °C) with optimised heat transfer
- Operation of easyDial user interface:
  - Central control unit, Convotherm-Dial (C-Dial)
  - Digital display
- Climate Management
  - Natural Smart Climate™ (ACS+), HumidityPro, Crisp&Tasty
- Quality Management
  - Airflow Management, BakePro, Multi-point core temperature probe
- Production Management
  - 99 cooking profiles each containing up to 9 steps
  - HACCP data storage
  - USB port
  - Regenerating function - regenerates products to their peak level
  - Preheat and cool down function
- Cleaning Management:
  - ConvoClean: Fully automatic cleaning system, with optional single-dose dispensing
- HygieniCare: safety by antibacterial surfaces
  - Hygienic Handles
- Door handle with safety latch and sure-shut function

- Adjustable appliance feet, from 100 mm to 125 mm
- Integrated recoil hand shower

### Options

- Steam and vapour removal (built-in condensation hood)
- Sous-vide sensor, with external socket
- Core temperature sensor, with external socket
- Ethernet / LAN interface
- Marine model
- Available in various voltages

### Accessories

- Stainless steel stand
- Stacking kit
- ConvoLink – HACCP and cooking profile management PC software
- ConvoVent 4 condensation hood with grease filter
- ConvoVent 4+ condensation hood with grease and odour filter
- Banquet system package: plate rack, mobile shelf rack, transport trolley, thermal cover (individual items are available)
- Care products for ConvoClean fully automatic cleaning system (multiple and single-dose dispensing)

# Convotherm maxx pro easyDial Combi Steamer

## CXESD6.10 ELECTRIC DIRECT STEAM 7 x 1/1 GN

Front view

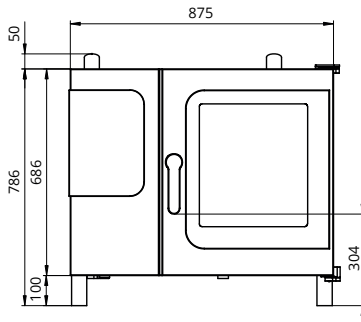

View from above with wall clearances

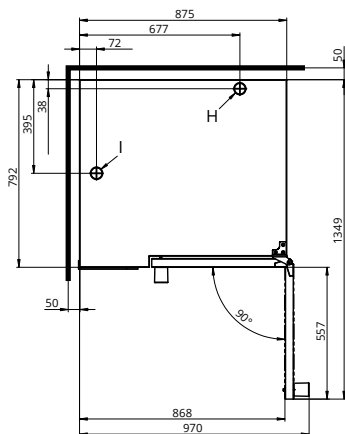

Connection points

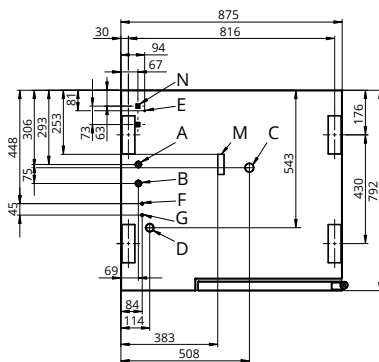

- A Water connection (for water injection)
- B Water connection (for cleaning, recoil hand shower)
- C Drain connection DN 50
- D Electrical connection
- E Equipotential bonding
- F Rinse-aid connection
- G Cleaning-agent connection
- H Air vent Ø 50 mm
- I Dry air intake Ø 50mm
- M Safety overflow 80 x 25 mm
- N RJ45 Ethernet port

### DIMENSIONS

Width	875 mm
Depth	792 mm
Height	786 mm
Weight	123kg

### PACKED DIMENSIONS

Width	1100 mm
Depth	940 mm
Height	1025 mm
Weight (including cleaning system)	148 kg

### Safety clearances\*

Rear	50 mm
Right	50 mm
Left (larger recommended for servicing)	50 mm
Top (for ventilation)	500 mm

\*Heat sources must lie at a minimum distance of 500 mm from the appliance.

### INSTALLATION REQUIREMENTS

For precise installation instructions please refer to the units installation manual

### LOADING CAPACITY

Max. number of food containers	
Shelf distance	68mm
GN 1/1 (with standard rack)	7
600 x 400 baking sheet (with appropriate rack)	5
Max. loading weight GN 1/1 / 600 x 400	
Per combi steamer	30 kg
Per shelf	15 kg

### ELECTRICAL SUPPLY

3N - 400V 50/60Hz (3P+N+E)	
Rated power consumption	11.0 kW
Rated current	15.9 A
Fuse	16 A
RCD (GFCI), frequency converter	Type A
(singlephase)	(recommended), type B (optional)

Special voltage options available on request.  
Connection to an energy optimisation system as standard.

### WATER CONNECTION

Water supply	
2 x G 3/4" permanent connection, optionally including connecting pipe (min. DN13 / 1/2")	
Flow pressure	150 - 600 kPa (1.5 - 6 bar)
Appliance drain	
Drain version	Permanent connection

(recommended) or funnel waste trap  
Type DN50 (min. internal Ø: 46 mm)  
Slope for waste-water pipe min. 3.5% (2°)

### WATER QUALITY

Drinking water	
(install water treatment system if necessary)	
Treated tap water for water injection	
Untreated tap water for cleaning, recoil hand shower	
Total hardness	
Injection (soft water)	4-7 °dh / 70-125 ppm / 7-13 °TH / 5-9 °e
Cleaning, recoil shower	4-20 °dh / 70 - 360 ppm / 7 - 35 °TH / 5 - 25 °e
Shower (hard water)	

### Properties

pH	6.5 - 8.5
Cl- (chloride)	max. 60 mg/l
Cl <sub>2</sub> (free chlorine)	max. 0.2 mg/l
SO <sub>4</sub> <sup>2-</sup> (sulphate)	max. 150 mg/l
Fe (iron)	max. 0.1 mg/l
Temperature	max. 40°C
Electrical conductivity	min. 20 µS/cm

### EMISSIONS

Heat output	
Latent heat	2100 kJ/h / 0.58 kW
Sensible heat	2500 kJ/h / 0.69 kW
Waste water temperature	max. 80 °C
Noise during operation	max. 70 dBA

### STACKING KIT

Permitted combinations	6.10 on 6.10 / 6.10 on 10.10
(Electric on electric appliance)	



moffat.com.au  
moffat.co.nz

Australia  
moffat.com.au

Moffat Pty Limited

Victoria/Tasmania  
740 Springvale Road  
Mulgrave, Victoria 3170  
Telephone +61 3-9518 3888  
Facsimile +61 3-9518 3833  
vsales@moffat.com.au

New South Wales  
Telephone +61 2-8833 4111  
nswsales@moffat.com.au

South Australia  
Telephone +61 3-9518 3888  
vsales@moffat.com.au

Queensland /  
Northern Territory  
Telephone +61 7-3630 8600  
qldsales@moffat.com.au

Western Australia  
Telephone +61 8-9413 2400  
wasales@moffat.com.au

New Zealand  
moffat.co.nz

Moffat Limited

Rolleston  
45 Illinois Drive  
Izone Business Hub  
Rolleston 7675  
Telephone +64 3-983 6600  
Facsimile +64 3-983 6660  
sales@moffat.co.nz

Auckland  
Telephone +64 9-574 3150  
sales@moffat.co.nz

In line with policy to continually develop and improve its products, Moffat Limited reserves the right to change specifications and design without notice.

© Copyright Moffat Ltd  
AN.CON.S.2101

