

Convotherm maxx pro easyTouch Combi Steamer

CXGST10.20D GAS DIRECT STEAM 22 x 1/1 GN or 11 x 2/1 GN

- Direct steam system
- Natural Smart Climate™ (ACS+) cooking methods: Steam, Combi-steam, Convection
- Natural Smart Climate™ extra functions:
 - Crisp&Tasty - 5 moisture removal settings
 - BakePro - 5 levels of traditional baking
 - HumidityPro - 5 humidity settings
 - Controllable fan - 5 speed settings
- easyTouch 10" TFT HiRes glass touch display (capacitive)
- ConvoClean+ fully automatic cleaning system with eco, regular and express modes, including optional single-dose dispensing
- HygieniCare
- WiFi and Ethernet interface (LAN)
- USB port integrated in the control panel
- Steam generated by injecting water into the oven chamber
- LED lighting in oven cavity
- Triple glass appliance door
- Right-hinged appliance door
- Disappearing door



Standard Features

- Cooking methods:
 - Steam (30-130°C) with guaranteed steam saturation
 - Combi-steam (30-250 °C) with automatic moisture control
 - Convection (30-250 °C) with optimised heat transfer
- Operation of easyTouch user interface:
 - 10" TFT HiRes glass touch display (capacitive)
 - Smooth-action, quick reacting scrolling function
- Climate Management
 - Natural Smart Climate™ (ACS+), HumidityPro, Crisp&Tasty
- Quality Management
 - Airflow Management, BakePro, Multi-point core temperature probe
 - Preheat and cool down function
- Production Management
 - Automatic cooking with Press&Go with up to 399 cooking profiles
 - Integrated cookbook with 7 different categories
 - TrayTimer – load management for different products at the same time (manual mode)
 - TrayView – load management for automatic cooking of different products using Press&Go
 - Favourites management
 - HACCP data storage
 - USB port
 - ecoCooking – energy-save function
 - LT cooking (low temperature cooking) / Delta-T cooking
 - Cook&Hold – cook and hold in one process
 - Autostart
 - Regenerate+ - flexible multi-mode rethermalisation function with preselect
- Cleaning Management:
 - ConvoClean+ - fully automatic cleaning system

- Quick access to individually created and saved cleaning profiles
- Cleaning scheduler
- FilterCare interface
- HygieniCare: safety by antibacterial surfaces
 - Hygienic Steam Function
 - Hygienic Handles
 - SteamDisinfect
- Door handle with safety latch and sure-shut function
- Adjustable appliance feet, from 100 mm to 125 mm
- Integrated recoil hand shower

Options

- ConvoSmoke – built in food-smoking function (HotSmoke)
- Steam and vapour removal (built-in condensation hood)
- Sous-vide sensor, with external socket
- Core temperature sensor, with external socket
- Available in various voltages

Accessories

- Stainless steel stand
- Stacking kit
- ConvoLink – HACCP and cooking profile management PC software
- Banquet system package: plate rack, mobile shelf rack, transport trolley, thermal cover (individual items are available)
- Care products for ConvoClean+ fully automatic cleaning system (multiple and single-dose dispensing)

Convotherm maxx pro easyTouch Combi Steamer

CXGST10.20D GAS DIRECT STEAM 22 x 1/1 GN or 11 x 2/1 GN

Front view

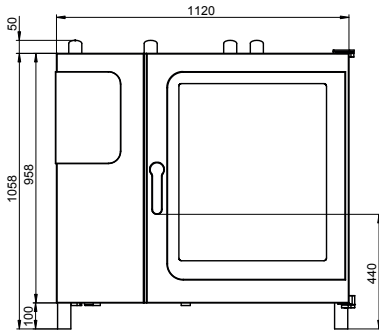

View from above with wall clearances

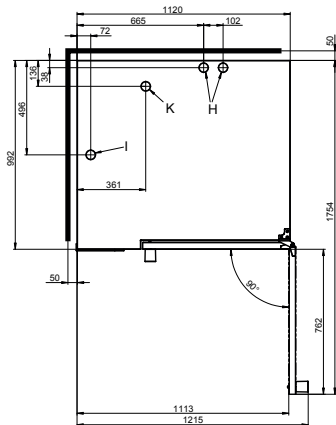

Connection points

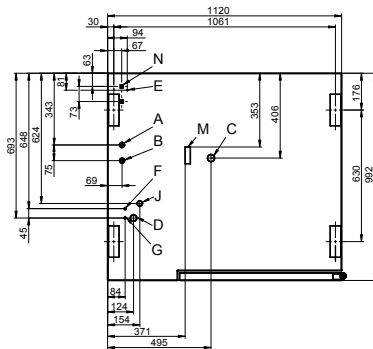

- A Water connection (for water injection)
- B Water connection (for cleaning, recoil hand shower)
- C Drain connection DN 50
- D Electrical connection
- E Equipotential bonding
- F Rinse-aid connection
- G Cleaning-agent connection
- H Air vent Ø 50 mm
- I Dry air intake Ø 50 mm
- J Gas supply
- K Exhaust outlet Ø 60.3 mm
- M Safety overflow 80 x 25 mm
- N RJ45 Ethernet port

DIMENSIONS

Width	1211 mm
Depth	992 mm
Height	1058 mm
Weight	206 kg

PACKED DIMENSIONS

Width	1345 mm
Depth	1140 mm
Height	1300 mm
Weight (including cleaning system)	244 kg

Safety clearances*

Rear	50 mm
Right	50 mm
Left (larger recommended for servicing)	50 mm
Top (for ventilation)	1000 mm

*Heat sources must lie at a minimum distance of 500 mm from the appliance.

INSTALLATION REQUIREMENTS

For precise installation instructions please refer to the units installation manual.

LOADING CAPACITY

Max. number of food containers	68 mm
Shelf distance	22
GN 1/1 (with standard rack)	11
GN 2/1 (with standard rack)	16
600 x 400 baking sheet (with appropriate rack)	16
Max. loading weight GN 1/1 / 600 x 400	100 kg
Per combi steamer	15 kg
Per shelf	

ELECTRICAL SUPPLY

1N~ 230-240V 50/60Hz (1P+N+E)	
Rated power consumption	0.6 kW
Rated current	2.3 A
Fuse	16 A
RCD (GFCI), frequency converter (recommended), type B/F (optional)	Type A Cordset fitted
3 Pin plug (10 Amp)	

GAS SUPPLY

Gas Connection for natural or LPG	R3/4
Installation conditions	customer premise
Nominal gas consumption	115 MJ/hr
Convection power output	115 MJ/hr

Supply flow pressure

Natural Gas	1.13kPa – 3kPa
LPG	2.75kPa – 4kPa

WATER CONNECTION

Water supply
 2 x G 3/4" permanent connection, optionally including connecting pipe (min. DN13 / 1/2")
 Flow pressure 150 - 600 kPa (1.5 - 6 bar)

Appliance drain

Drain version Permanent connection (recommended) or funnel waste trap
 Type DN50 (min. internal Ø: 46 mm)
 Slope for waste-water pipe min. 3.5% (2°)

WATER QUALITY

Drinking water
 (Install water treatment system if necessary)
 Treated tap water for water injection
 Untreated tap water for cleaning, recoil hand shower

Total hardness

Injection (soft water)	4-7 °dh / 70-125 ppm / 7-13 °TH / 5-9 °e
Cleaning, recoil shower	4-20 °dh / 70 - 360 ppm / 7 - 35 °TH / 5 - 25 °e
Shower (hard water)	

Properties

pH	6.5 - 8.5
Cl ⁻ (chloride)	max. 60 mg/l
Cl ₂ (free chlorine)	max. 0.2 mg/l
SO ₄ ²⁻ (sulphate)	max. 150 mg/l
Fe (iron)	max. 0.1 mg/l
Temperature	max. 40°C
Electrical conductivity	min. 20 µS/cm

EMISSIONS

Heat output	
Latent heat	4700 kJ/h / 1.31 kW
Sensible heat	6100 kJ/h / 1.69 kW
Waste water temperature	max. 80 °C
Noise during operation	max. 70 dBA

STACKING KIT

Permitted combinations (Gas on gas appliance)	6.20 on 10.20
---	---------------



moffat.com.au
 moffat.co.nz

Australia
 moffat.com.au

Moffat Pty Limited

Victoria/Tasmania
 740 Springvale Road
 Mulgrave, Victoria 3170
 Telephone +61 3-9518 3888
 Facsimile +61 3-9518 3833
 vsales@moffat.com.au

New South Wales
 Telephone +61 2-8833 4111
 nswsales@moffat.com.au

South Australia
 Telephone +61 3-9518 3888
 vsales@moffat.com.au

Queensland /
 Northern Territory
 Telephone +61 7-3630 8600
 qldsales@moffat.com.au

Western Australia
 Telephone +61 8-9413 2400
 wasales@moffat.com.au

New Zealand
 moffat.co.nz

Moffat Limited

Rolleston
 45 Illinois Drive
 Izone Business Hub
 Rolleston 7675
 Telephone +64 3-983 6600
 Facsimile +64 3-983 6660
 sales@moffat.co.nz

Auckland
 Telephone +64 9-574 3150
 sales@moffat.co.nz

In line with policy to continually develop and improve its products, Moffat Limited reserves the right to change specifications and design without notice.

© Copyright Moffat Ltd
 AN.CON.S.2101

