

Dear customer,



Please read these user instructions carefully before connecting the appliance to prevent damage due to improper use. Please pay special attention to the safety regulations.

Safety regulations

- Incorrect operation and improper use of the appliance can seriously damage the appliance and injure users.
- The appliance may only be used for the purpose for which it was intended and designed. The manufacturer is not liable for any damage caused by incorrect operation and improper use.
- This appliance is intended solely for slicing food.
- Always keep an eye on the appliance when in use.
- Children do not understand that incorrect use of electrical appliances can be dangerous. Therefore, never let children use home appliances without supervision.
- Do not use any extra devices that are not supplied along with the appliance.

Preparations before using for the first time

- Check that all parts are included. If any parts are missing, contact your supplier.
- Remove all the packing material.
- Clean the vegetable slicer with lukewarm water and a soft cloth.

	Cutters 4, 6 and 10 mm
	Safety grip
	Vegetable slicer

Instructions for use

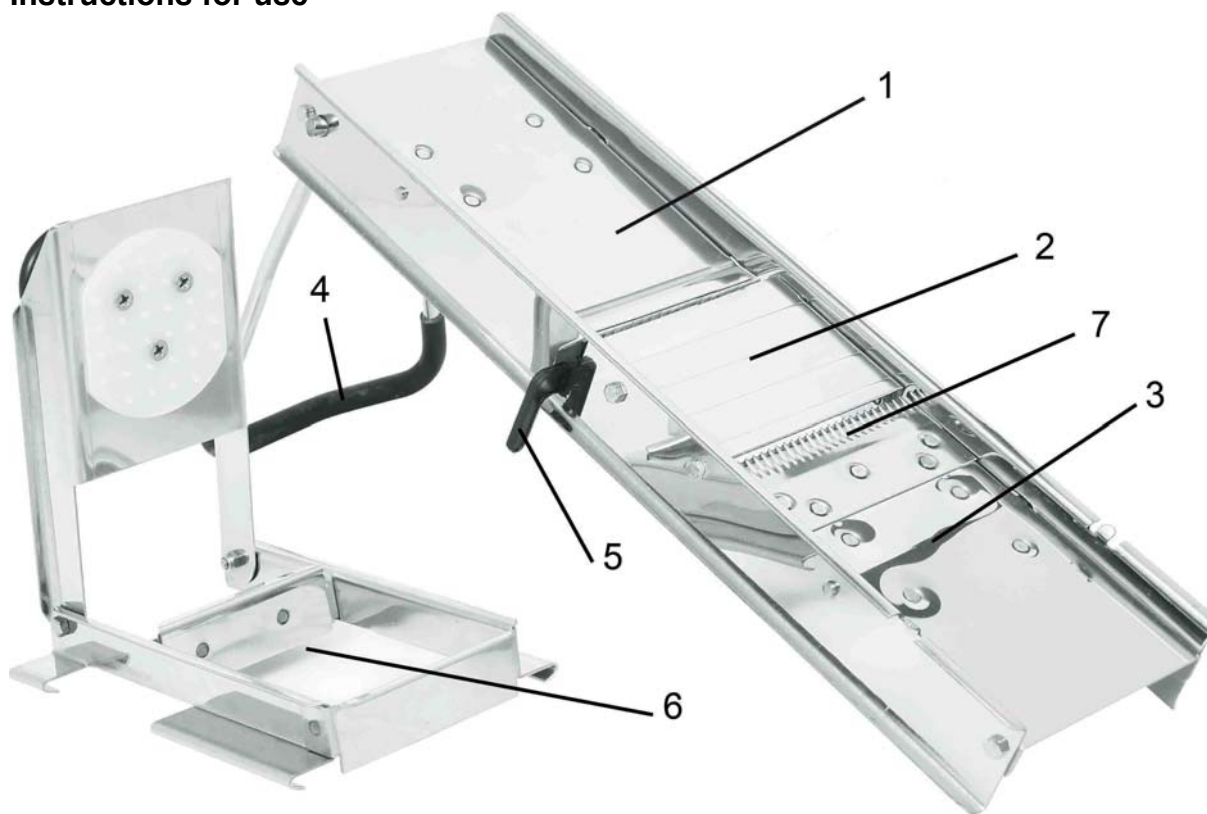

1	Thickness adjustment for cutting slices and batons
2	Slicer
3	Thickness adjustment for grating and ribble cut slicing
4	Folding stand
5	Cutter 4, 6 of 10 mm
6	Safety grip
7	Ribble cut slicer

- Turn the slicer upside down exposing the stand (Part 4)
- Unfold the stand to its maximum position as visible on the picture.
- Place the safety grip on the slicer. The arrow on the knob must point downwards.

Cutting straight slices

- Adjust, with the lever (part 1) on the underside of the slicer, the desired thickness (0 – 10 mm) of the slices.
- Place the product in the safety grip.
- Move the safety grip downwards till it can move no further.
- Repeat this movement till there is no product left.

Cutting batons

- Adjust the lever (part 1) to the desired thickness (0 – 10 mm) for the batons.
- Choose the right cutter for the desired baton size: 4, 6 of 10 mm
- Place the cutter at the designated place (Part 5)
- Place the product in the safety grip.
- Move the safety grip downwards till it can move no further.
- Repeat this movement till there is no product left.

Cutting ribblecut slices

- Remove the safety grip
- Adjust the lever (part 1) to “0” and remove the cutter, so you cannot cut yourself
- Adjust the lever (part 3) on the underside of the slicer the desired thickness (3 – 5 mm) of the slices. When the slices fall apart, increase the adjustment
- Take the product you want to slice in the palm of your hand and cut the slices
- By turning the product you can vary the pattern.

Grating products

- Remove the safety grip
- Adjust the lever (part 1) to “0” and remove the cutter, so you cannot cut yourself
- Adjust the lever (part 3) on the underside of the slicer the desired thickness (0,5 – 2 mm) for grating
- Take the product you want to grate in the palm of your hand and start grating

Cleaning and maintenance

- The vegetable slicer is dishwasher safe
- First remove the cutter and safety grip before you place the vegetable slicer in the dishwasher.
- Never use aggressive cleaning agents or abrasives. Do not use any sharp or pointed objects. Do not use petrol or solvents! Clean with a damp cloth and detergent if necessary. Do not use abrasive materials.

Guarantee

Any defect affecting the functionality of the appliance which becomes apparent within one year of its purchase will be corrected by free repair or replacement provided that it has been used and maintained in accordance with the instructions and has not been abused or misused in any way. Your statutory rights are not affected. If it's under guarantee, state where and when it was bought, and include proof of purchase (e.g. till receipt). In line with our policy of continuous product development we reserve the right to change product, packaging and documentation specifications without notice.

Discard

At the end of the life of the appliance, please cast of the appliance according to the on that moment applying regulations and guidelines.