

Varimixer

# KODIAK10

Table model

**VERY SIMPLE INTUITIVE OPERATION** Set the time and speed. Press start and stop. It's that simple, and everything is controlled at an ergonomic working height from the angled control panel.

**FRONT ATTACHMENT DRIVE** KODIAK is also available with an attachment drive for meat mincers and vegetable slicers.

**PATENTED DETACHABLE SAFETY GUARD** The guard has an integrated filling tray, is made of transparent plastic and is dishwasher-safe. It can be attached instantly without tools. The guard is held in place by magnets, which also serve as a safety cut-off.

**WORLD'S MOST EFFECTIVE TOOL** Unique design increases speed at the periphery and reduces the working time.



**IP44** Varimixer KODIAK can be cleaned in line with the IP44 standard.

**ERGONOMIC RAISING AND LOWERING** The ergonomically designed handle lowers and raises the bowl and locks it in place in a single movement.

**STAINLESS STEEL** Made of easy-to-clean stainless steel with a strong frame and high, adjustable legs, to allow cleaning under the machine. The bowl, wire whip, beater, dough hook and scraper are also made of stainless steel and are dishwasher-safe.

**HEIGHT-ADJUSTABLE LEGS**

**RUNS ON 230 VOLTS** KODIAK can be connected to a normal power outlet. A frequency converter and a three-phase motor make Varimixer KODIAK a very powerful mixer.

## VARIMIXER KODIAK10 OPTIONS – MODELS



Floor model, stainless steel



Marine version, stainless steel



Attachment drive for meat mincer and vegetable cutter



Meat mincer, 70 mm



Vegetable cutter GR10

## VARIMIXER KODIAK10 STANDARD TOOLS



Hook, whip, beater and bowl 10L in stainless steel.

## SAFETY GUARD



Removable magnetic safety guard.

## ACCESSORIES - TOOLS



Automatic scraper in stainless steel.



Tool rack, 91 cm

## VARIMIXER KODIAK10 STANDARD

Stainless steel construction  
 Removable magnetic safety guard guard plastic  
 Digital timer and emergency stop  
 Scraper holder  
 1 bowl 10 liter in stainless steel  
 1 beater in stainless steel  
 1 hook in stainless steel  
 1 whip in stainless steel, 3mm wires  
 Voltage: 1 ph, 230V, 50-60 Hz with 0 and ground. 700 W

## VARIMIXER KODIAK10 STANDARD TECHNICAL DATA

Volume	10 l
Effect	700 W
Voltage*	230 V
Residual current devices (RCD): Industrial environment Light industry/domestic	HPFI type A-SI or PFI type B HPFI type A-SI
Net weight table model	53 kg
H x W x L table model	674 x 393 x 566 mm
Shipping gross weight table model	60 kg
Shipping dimensions H x W x L table model	890 x 474 x 660 mm
Variable speed	72 - 451 RPM
Phases	1 ph
IP code	IP44

\*Other voltage power supply are available upon request in the range of 100 to 480 V.  
 All standard and marine mixers are available in 50 and 60 Hz.

## VARIMIXER KODIAK10 MARINE VERSION

Slottet free screws. External transformer. Complies with USPHS.

Voltage: 2 ph, 400V, 50-60 Hz, with 0 and ground. 700 W  
 2 ph, 440V, 50-60 Hz, with 0 and ground. 700 W  
 2 ph, 480V, 50-60 Hz, with 0 and ground. 700 W

## CAPACITIES

Tool	Product	Capacity	Unit	Special attention
Whip	Egg whites, minimum capacity	0.25	L	+
	Egg whites, maximum capacity	0.5	L	+
	Whipped cream, minimum capacity	0.4	L	+
	Whipped cream, maximum capacity	2.5	L	+
	Buttercream frosting	4.0	Kg	▲+
Beater	Herb butter	2.5	Kg	▲+
	Icing, Fondant	3.0	Kg	
	Cakes (US Pound cake)	5.0	Kg	
	Mashed potatoes (powder)	5.0	Kg	●+
	Mashed potatoes	4.0	Kg	●+
	Meatball mix/vegan meatball mix	6.0	Kg	+
Hook	Pasta, noodles	3.0	Kg	○
	Dough, rye bread	6.6	Kg	+
	Dough, sourdough bread	5.5	Kg	○
	Dough, bread 55%AR	5.0	Kg	○
	Dough, bread 60%AR	5.0	Kg	○
	Dough, whole wheat 50%AR	5.0	Kg	○
	Dough, whole wheat 70%AR	5.5	Kg	○
	Dough, gluten free	4.5	Kg	●

The capacity chart shows the maximum capacity for the specific machine. The testing has been conducted with standard equipment. Therefore, the use of special tools, can result in a different outcome. Always start the machine at the lowest speed. Increase the speed subsequently, taking the product being mixed into account.

### Symbol explanation:

- = For these products, it is recommended to work at low speed.
- + = Recommended to apply scraper, for the best and most efficient result.
- ▲ = Always make sure the ingredients are room temperature/soft. If not, this can damage the tools.
- = It is recommended not to go above medium speed.
- %AR = Absorption Ratio (moisture in % of dry matter)

## CERTIFICATIONS



## DIMENSIONS

Table model, standard

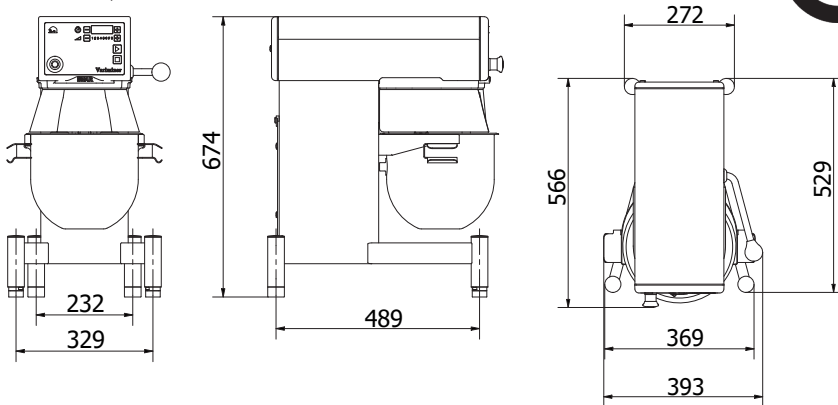
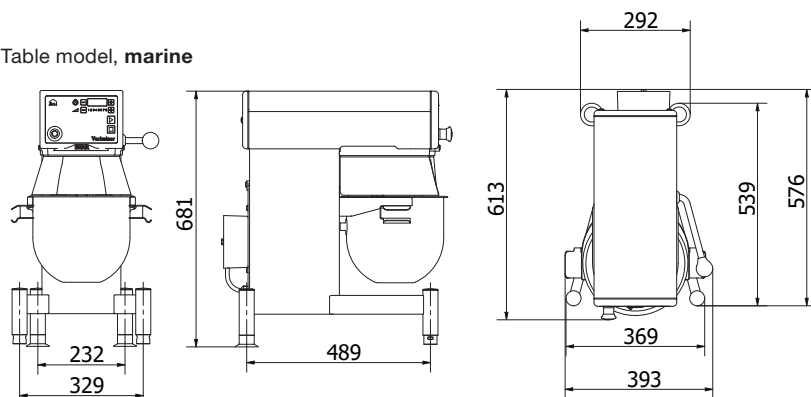

Table model, marine



# Varimixer

Varimixer A/S  
 Kirkebjerg Søpark 6  
 DK-2605 Brøndby  
 P: +45 4344 2288  
 E: info@varimixer.com  
 www.varimixer.com