

ALTO SHAAM®
HALO
HEAT®



**INSTALLATION
OPERATION
AND
MAINTENANCE
MANUAL**

***BANQUET
CARTS***

MODELS:

1000-BQ2/96

1000-BQ2/128

1000-BQ2/192

W164 N9221 Water Street • P.O. Box 450 • Menomonee Falls, Wisconsin 53052-0450 USA

PHONE: 262.251.3800

800.558-8744 USA/CANADA

FAX: 262.251.7067 • 800.329.8744 U.S.A. ONLY

262.251.1907 INTERNATIONAL

WEBSITE:

www.alto-shaam.com

ALTO-SHAAM® HOLDING CABINETS

UNPACKING and SET-UP

The Alto-Shaam holding cabinet has been thoroughly tested, checked for calibration, and inspected to insure only the highest quality cabinet is provided. When you receive your unit, check for any possible shipping damage and report it at once to the delivering carrier. See *Transportation Damage and Claims section* located in this manual.

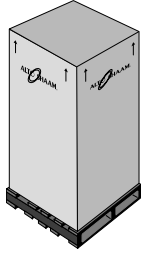

The cabinet, complete with unattached items and accessories, may be delivered in one or more packages. Check to insure that all the following items have been received as standard with each unit:

Item	BQ2/96	BQ2/128	BQ2/192
Shelves	4	4	8
Shelf Clips	4	4	8
Shelf Slides	8	8	16

Save all the information and instructions packed inside the cabinet. Complete and return the warranty card to the factory as soon as possible to assure prompt service in the event of a warranty parts and labor claim.

Alto-Shaam holding cabinets are designed for the purpose of maintaining hot food at a temperature for safe consumption. The unit must be installed in a location that will permit the equipment to function for its intended purpose and allow adequate access for proper cleaning and maintenance.

NOTE: Any claims for warranty must include the full model number and serial number of the cabinet.

HEATING CHARACTERISTICS

The holding cabinet is equipped with a special heating cable. Through this Halo Heat concept, the heating cable is mounted against the walls of the unit to provide an evenly applied heat source controlled by a thermostat. The design and operational characteristics of the unit eliminate the need for a moisture pan or a heat circulating fan. Through even heat application, the quality of food products is maintained up to several hours or more.

ELECTRICAL INSTALLATION

1. An identification tag is permanently mounted on the cabinet.

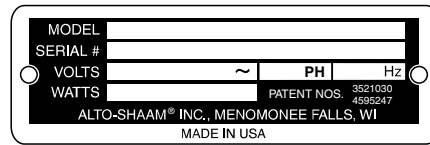

2. Plug cabinet into a properly grounded receptacle ONLY, positioning the unit so the power supply cord is easily accessible in case of an emergency.

**ENSURE POWER SOURCE MATCHES
VOLTAGE STAMPED
ON NAMEPLATE OF UNIT**



3. If necessary, a proper receptacle or outlet configuration as required for this unit, must be installed by a licensed electrician in accordance with applicable, local electrical codes.

230V units: To prevent an electrical shock hazard between the appliance and other appliances or metal parts in close vicinity, an equalization-bonding stud is provided. An equalization bonding lead must be connected to this stud and the other appliances / metal parts to provide sufficient protection against potential difference. The terminal is marked with the following symbol.



Note: The appliance must be connected to an electrical circuit that is protected by an external GFCI outlet.

Disconnect unit from power source before cleaning or servicing.

At no time should the unit be steamed cleaned, washed down or flooded with water or liquid solution. Do not use water jet to clean. Severe damage or electrical hazard could result.



Warranty becomes void if unit is flooded.

START-UP/INSTALLATION

1. The unit must not be installed in any area where it may be affected by steam, grease, dripping water, high temperatures, or any other severely adverse conditions.
2. Before operating the unit, clean both the interior and exterior of the unit with a clean, damp cloth and mild soap solution. Rinse carefully. Clean and install the shelf slides and shelves.
3. Before operating the unit, become familiar with the operation of the controls. Read this manual and keep it in a secure location.

INSTALLATION

Outside Dimensions

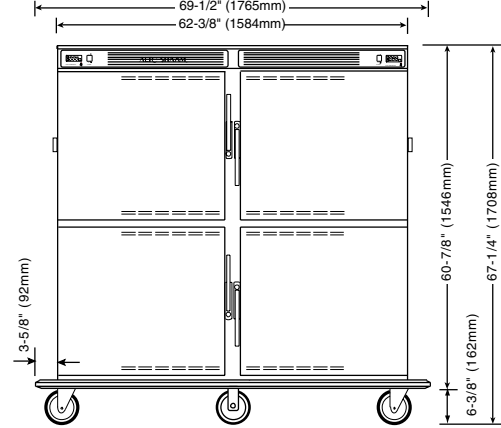
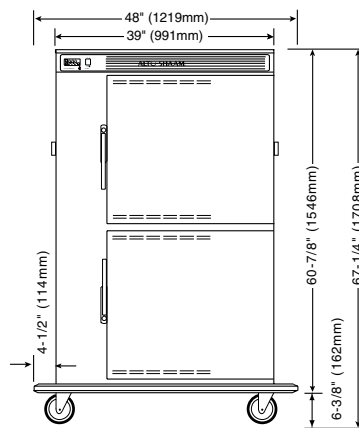
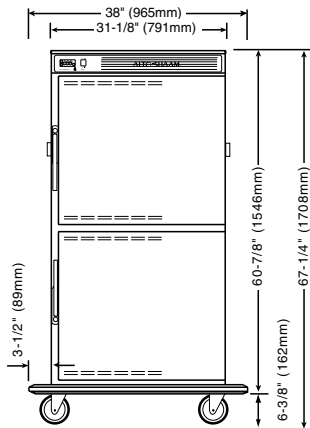
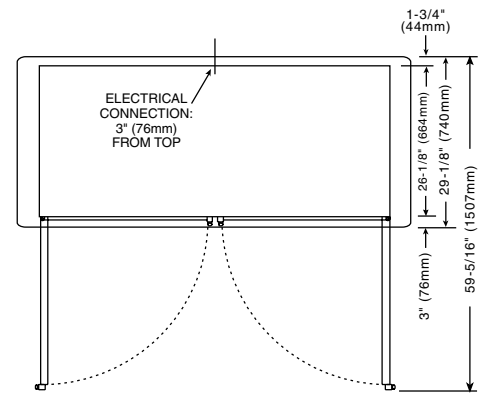
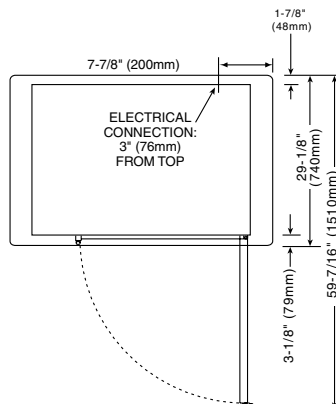
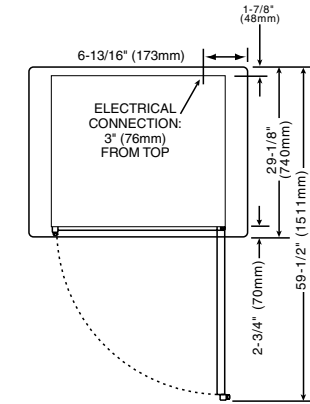

1000-BQ2/96
Max. Load Capacity
240 lbs. (109 kg)

1000-BQ2/128
Max. Load Capacity
320 lbs. (145 kg)

1000-BQ2/192
Max. Load Capacity
480 lbs. (218 kg)

Options and Accessories

	BQ2/96	BQ2/128	BQ2/192
Plate Carriers, Chrome Plated (EACH HOLDS FOUR (4) PREPLATED MEALS)			
Uncovered "P" Carriers DC-2868			
Plate Diameter: Max. 10" (254mm) Min. 7-3/4" (197mm)			
Vertical rung spacing: 2-5/8" (67mm)			
Capacity:	24 carriers 96 Preplated Meals	32 carriers 128 preplated meals	48 carriers 192 preplated meals
Covered "C" Carriers DC-2869			
Plate Diameter: Max. 9-3/4" (248mm) Min. 7-3/4" (197mm)			
Vertical clearance between top and bottom carrier: 11-5/8" (295mm)			
Capacity:	24 carriers 96 Preplated Meals	32 carriers 128 preplated meals	48 carriers 192 preplated meals
Uncovered "EP" Carriers DC-23580			
Plate Diameter: Max. 12-1/2" (318mm) Min. 9-1/2" (241mm)			
Vertical rung spacing: 2-5/8" (67mm)			
Capacity:	16 carriers 64 Preplated Meals	24 carriers 96 preplated meals	32 carriers 128 preplated meals
Covered "EC" Carriers DC-23676			
Plate Diameter: Max. 12-1/2" (318mm) Min. 9-1/2" (241mm)			
Vertical clearance between top and bottom carrier: 11-5/8" (295mm)			
Capacity:	16 carriers, 64 Preplated Meals	24 carriers 96 preplated meals	32 carrers 128 preplated meals
Shelf & Shelf Supports (for each extra shelf) 1061/11533			
Wire Shelf, Chrome Plated SH-2835 SH-22727 SH-2835			

OPERATION

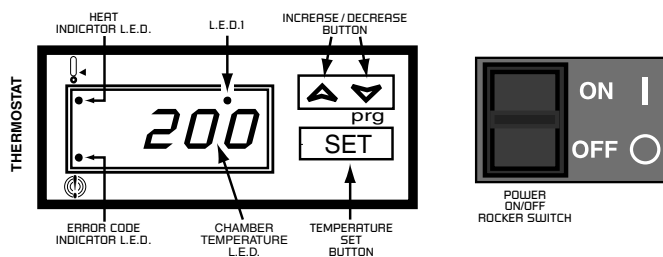

Note: The Fahrenheit or Celsius temperature scale is set at the factory before the cart is shipped.

VIEW or CHANGE HOLDING TEMPERATURE.....

1. Push the SET button once. The set point value (current holding temperature) will be displayed for 5 seconds.
2. This temperature can be changed by pressing and holding the SET button for at least 3 seconds. The programming mode becomes active and the LED1 indicator light will blink. Press and hold the UP or DOWN arrow keys to change the value shown in the display. This value can be stored by pressing the SET button again. The new set temperature will flash three times to confirm. The minimum set point temperature is 90°F (32°C) while the maximum set point temperature is 200°F (93°C).

START-UP....

1. Connect the electric cord to an appropriate power outlet.
2. Close the compartment vents located on the inside of each compartment door.
3. Press the power switches ON for the appropriate compartments. The heat indicator light will illuminate and remain lit while the unit is calling for heat. The digital display will indicate air temperature of the heated compartment. The heat indicator light will go out when the air temperature inside the unit reaches the temperature set on the electronic thermostat.

HOLDING....

1. **Preheat at 200°F for 30 minutes.**
Allow a minimum of 30 minutes for preheating before loading the banquet cart with product.
2. **Load the cart with hot food only.**
The purpose of the banquet cart is to maintain hot food at proper serving temperature. **Only hot food should be placed into the banquet cart.** Before loading the cart with food, use a food thermometer to make certain all products

have reached an internal temperature range of 140° to 160°F (60° to 71°C). Any food product not within the proper temperature range should be heated before loading into the banquet cart. For best results, use a Halo Heat Low Temperature Cooking and Holding Oven set at 250° to 275°F (121° to 135°C), or a Combitherm oven, to bring the product within the correct temperature range.

3. Load covered plates or carriers into the banquet cart.

After the food has reached proper serving temperature:

- A. Use HEATED plates only.
- B. Load each series of four (4) plates into the banquet cart as soon as assembled and as quickly as possible to retain maximum heat.
- C. Load the plates in the upper section of the banquet cart first.
- D. Securely close the doors of the banquet cart after loading each series of plates.
- E. When loading the upper section of the banquet cart, the door on the lower section should remain closed.
- F. When loading the lower section of the banquet cart, the door on the upper section should remain closed.

4. Reset the thermostat to desired temperature.

After the cart has been completely filled with product, check to make certain the doors are securely closed, and reset the thermostat to the desired holding temperature or the suggested 180°F (82°C).

The proper temperature range for the products being held, and whether or not to open or close the door vents, will depend on the type and quantity of product. When holding food for prolonged periods, it is advisable to periodically check the internal temperature of each item with a food thermometer to assure maintenance of the proper temperature range of 140° to 160°F (60° to 71°C).

5. UNLOAD COVERED PLATES, TRAYS OR PLATE CARRIERS AS NEEDED.

- A. Unload the items from the lower section of the cart first, and work up toward the top of the cart.
- B. When unloading the lower section of the banquet cart, the door on the upper section should remain closed.
- C. When unloading the upper section of the cart, the door on the lower section should remain closed.
- D. Securely close the doors of the cart after each product removal.

GENERAL HOLDING GUIDELINES

Chefs, cooks and other specialized food service personnel employ varied methods of cooking. Proper holding temperatures for a specific food product must be based on the moisture content of the product, product density, volume, and proper serving temperatures. Safe holding temperatures must also be correlated with palatability in determining the length of holding time for a specific product.

Halo Heat maintains the maximum amount of product moisture content without the addition of water, water vapor, or steam. Maintaining maximum natural product moisture preserves the natural flavor of the product and provides a more genuine taste. In addition to product moisture retention, the gentle properties of Halo Heat maintain a consistent temperature throughout the cabinet without the necessity of a heat distribution fan, thereby preventing further moisture loss due to evaporation or dehydration.

HOLDING TEMPERATURE RANGE		
MEAT	FAHRENHEIT	CELSIUS
BEEF ROAST — Rare	140°F	60°C
BEEF ROAST — Med/Well Done	160°F	71°C
BEEF BRISKET	160° — 175°F	71° — 79°C
CORN BEEF	160° — 175°F	71° — 79°C
PASTRAMI	160° — 175°F	71° — 79°C
PRIME RIB — Rare	140°F	60°C
STEAKS — Broiled/Fried	140° — 160°F	60° — 71°C
RIBS — Beef or Pork	160°F	71°C
VEAL	160° — 175°F	71° — 79°C
HAM	160° — 175°F	71° — 79°C
PORK	160° — 175°F	71° — 79°C
LAMB	160° — 175°F	71° — 79°C
POULTRY		
CHICKEN — Fried/Baked	160° — 175°F	71° — 79°C
DUCK	160° — 175°F	71° — 79°C
TURKEY	160° — 175°F	71° — 79°C
GENERAL	160° — 175°F	71° — 79°C
FISH/SEAFOOD		
FISH — Baked/Fried	160° — 175°F	71° — 79°C
LOBSTER	160° — 175°F	71° — 79°C
SHRIMP — Fried	160° — 175°F	71° — 79°C
BAKED GOODS		
BREADS/ROLLS	120° — 140°F	49° — 60°C
MISCELLANEOUS		
CASSEROLES	160° — 175°F	71° — 79°C
DOUGH — Proofing	80° — 100°F	27° — 38°C
EGGS —Fried	150° — 160°F	66° — 71°C
FROZEN ENTREES	160° — 175°F	71° — 79°C
HORS D'OEUVRES	160° — 180°F	71° — 82°C
PASTA	160° — 180°F	71° — 82°C
PIZZA	160° — 180°F	71° — 82°C
POTATOES	180°F	82°C
PLATED MEALS	180°F	82°C
SAUCES	140° — 200°F	60° — 93°C
SOUP	140° — 200°F	60° — 93°C
VEGETABLES	160° — 175°F	71° — 79°C
The holding temperatures listed are suggested guidelines only.		

In an enclosed holding environment, too much moisture content is a condition which can be relieved. A product achieving extremely high temperatures in preparation must be allowed to decrease in temperature before being placed in a controlled holding atmosphere. If the product is not allowed to decrease in temperature, excessive condensation will form increasing the moisture content on the outside of the product.

Most Halo Heat holding equipment is provided with a thermostat control between 60° and 200°F (16° to 93°C). If the unit is equipped with vents, close the vents for moist holding and open the vents for crisp holding.

If the unit is equipped with a thermostat indicating a range of between 1 and 10, use a metal-stemmed indicating thermometer to measure the internal temperature of the product(s) being held. Adjust the thermostat setting to achieve the best overall setting based on internal product temperature.

CARE and CLEANING



The cleanliness and appearance of this unit will contribute considerably to operating efficiency and savory, appetizing food. Good equipment kept clean works better and lasts longer.

THOROUGHLY CLEAN THE UNIT DAILY

1. Disconnect unit from power source, and let cool.
2. Remove all detachable items such as plate carriers, shelves and side racks. Clean these items separately with a good grease solvent or commercial detergent. Rinse well and dry.
3. Clean interior metal surfaces of the unit with a damp, clean cloth and any good commercial detergent or grease solvent at the recommended strength. Spray heavily soiled areas with a water soluble degreaser and let stand for 10 minutes, then remove soil with a plastic scouring pad. Rinse by wiping with a sponge and clean warm water to remove all residue. Remove excess water with sponge and wipe dry with a clean cloth or air dry. Replace side racks and shelves.
4. Clean control panel, door vents, door handles, and door gaskets thoroughly since these areas harbor food debris. Rinse by wiping with sponge and clean warm water. Wipe dry with a clean cloth.
5. Interior can be wiped with a sanitizing solution after cleaning and rinsing. This solution must be approved for use on stainless steel food contact surfaces.
6. To help maintain the protective film coating on polished stainless steel, clean the exterior of the unit with a cleaner recommended for stainless steel surfaces. Spray the cleaning agent on a clean cloth and wipe with the grain of the stainless steel.



NO SCRAPERS



NO STEEL PADS

NOTE: Avoid the use of abrasive cleaning, compounds, chloride based cleaners, or cleaners containing quaternary salts. Never use hydrochloric acid (muriatic acid) on stainless steel.

Always follow appropriate state or local health (hygiene) regulations regarding all applicable cleaning and sanitation requirements for foodservice equipment.

At no time should the inside or outside of the unit be washed down, flooded with water or liquid solution.

NEVER STEAM CLEAN.

Do not use water jet to clean.



CAUTION

Severe damage or electrical hazard could result.



CAUTION

Warranty becomes void if unit is flooded.

SANITATION

Food flavor and aroma are usually so closely related that it is difficult, if not impossible, to separate them. There is also an important, inseparable relationship between cleanliness and food flavor. Cleanliness, top operating efficiency, and appearance of equipment contribute considerably to savory, appetizing foods. Good equipment that is kept clean, works better and lasts longer.

Most food imparts its own particular aroma and many foods also absorb existing odors. Unfortunately, during this absorption, there is no distinction between GOOD and BAD odors. The majority of objectionable flavors and odors troubling food service operations are caused by bacteria growth. Sourness, rancidity, mustiness, stale or other OFF flavors are usually the result of germ activity.

The easiest way to insure full, natural food flavor is through comprehensive cleanliness. This means good control of both visible soil (dirt) and invisible soil (germs). A thorough approach to sanitation will provide essential cleanliness. It will assure an attractive appearance of equipment, along with maximum efficiency and utility. More importantly, a good sanitation program provides one of the key elements in the prevention of food-borne illnesses.

A controlled holding environment for prepared foods is just one of the important factors involved in the prevention of food-borne illnesses. Temperature monitoring and control during receiving, storage, preparation, and the service of foods are of equal importance.

The most accurate method of measuring safe temperatures of both hot and cold foods is by internal product temperature. A quality thermometer is an effective tool for this purpose, and should be routinely used on all products that require holding at a specific temperature.

A comprehensive sanitation program should focus on the training of staff in basic sanitation procedures. This includes personal hygiene, proper handling of raw foods, cooking to a safe internal product temperature, and the routine monitoring of internal temperatures from receiving through service.

Most food-borne illnesses can be prevented through proper temperature control and a comprehensive program of sanitation. Both these factors are important to build quality service as the foundation of customer satisfaction. Safe food handling practices to prevent food-borne illness is of critical importance to the health and safety of your customers. HACCP, an acronym for Hazard Analysis (at) Critical Control Points, is a quality control program of operating procedures to assure food integrity, quality, and safety. Taking steps necessary to augment food safety practices are both cost effective and relatively simple. While HACCP guidelines go far beyond the scope of this manual, additional information is available by contacting:

Center for Food Safety and Applied Nutrition
Food and Drug Administration
1-888-SAFEFOOD

INTERNAL FOOD PRODUCT TEMPERATURES		
HOT FOODS		
DANGER ZONE	40° TO 140°F	(4° TO 60°C)
CRITICAL ZONE	70° TO 120°F	(21° TO 49°C)
SAFE ZONE	140° TO 165°F	(60° TO 74°C)
COLD FOODS		
DANGER ZONE	ABOVE 40°F	(ABOVE 4°C)
SAFE ZONE	36°F TO 40°F	(2°C TO 4°C)
FROZEN FOODS		
DANGER ZONE	ABOVE 32°F	(ABOVE 0°C)
CRITICAL ZONE	0° TO 32°F	(-18° TO 0°C)
SAFE ZONE	0°F OR BELOW	(-18°C OR BELOW)

SERVICE SECTION

This chart is provided for the assistance of qualified technicians only and is not intended for use by untrained or unauthorized service personnel. If your unit is not operating properly, check the following before calling your authorized service agent. Check the power applied to the unit. Plug in outlet? Fuse OK?



Do not attempt to repair or service beyond this point. Contact manufacturer for nearest authorized service agent. Repairs made by any other service agent without prior authorization by manufacturer will void the warranty on the unit.

CAUTION

Trouble Shooting Guide

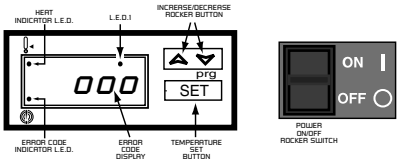
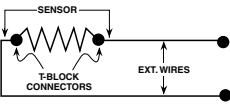
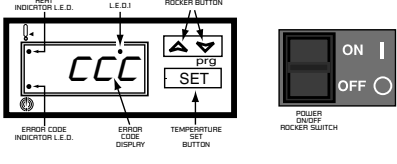
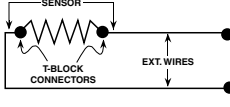
Error Code	Possible Cause	Action Required
<p>1. Control displays "OOO" or "PFO".</p> 	<p>A. Sensor is open circuited.</p>  <p>B. Associated wiring is open circuited.</p> <p>C. Control is faulty.</p>	<p>Detach the sensor from the terminal block. Use an Ohm meter to measure the resistance of the sensor. Check sensor at 32°F (0°C) using a container of ice water. If Ohm reading is 100, replace display. If Ohm reading is not 100, replace sensor.</p> <p>Check wires for integrity. Check for proper and secure connections at the thermostat and terminal block. If necessary, re-secure the faulty connections.</p> <p>Energize system after the above steps have been completed. If control still reads "OOO", call service technician.</p>
<p>2. Control displays "CCC" or "PFC".</p> 	<p>A. Sensor is short circuited.</p>  <p>B. Associated wiring is short circuited.</p> <p>C. Control is faulty.</p>	<p>Detach the sensor from the terminal block. Use an Ohm meter to measure the resistance of the sensor. Check sensor at 32°F (0°C) using a container of ice water. If Ohm reading is 100, replace display. If Ohm reading is not 100, replace sensor.</p> <p>Check wires for integrity. Check for proper and secure connections at the thermostat and terminal block. If necessary, re-secure the faulty connections.</p> <p>Energize system after the above steps have been completed. If control still reads "CCC", call service technician.</p>
<p>3. Unit does not operate.</p>	<p>A. Insufficient power supply. B. Defective power cord or plug.</p>	<p>Check power source. Check and replace if necessary.</p>
<p>4. No display in electronic control.</p>	<p>A. Faulty power supply board. B. Faulty electronic control.</p>	<p>Check line voltage for 24V across pins 6 and 7 on the power supply board. Replace control.</p>
<p>5. Cannot control temperature but sensor and electronic control check out OK.</p>	<p>A. Faulty relay. B. Heating element sensor.</p>	<p>Replace relay. Replace element.</p>
<p>6. Temperature readout incorrect.</p>	<p>A. Dirty or faulty sensor. B. Faulty control.</p>	<p>Detach the sensor from the terminal block. Use an Ohm meter to measure the resistance of the sensor. Check sensor at 32°F (0°C) using a container of ice water. If Ohm reading is 100, replace display. If Ohm reading is not 100, replace sensor.</p>



CAUTION

**DISCONNECT UNIT FROM POWER SOURCE
BEFORE CLEANING OR SERVICING.**

THERMOSTAT ACCURACY

The electronic thermostat is a precise instrument and is designed to offer trouble free service. If you suspect the temperature inside the holding compartment does not match the temperature indicated on the digital display, follow the instructions listed below.

1. Check to make certain the unit voltage matches the power source. A power source less than that required to operate the unit will result in inaccurate temperatures.
2. Verify the temperature inside the holding compartment with a qualify thermal indicator.
 - A. With the exception of the wire shelves, completely empty the holding compartment.
 - B. Make certain the holding cabinet sensor, located inside the holding compartment at the left side of the unit, is completely clean.
 - C. Suspend the thermal indicator in the center of the holding compartment.
 - D. Allow the temperature set on the electronic thermostat to stabilize for a minimum of one hour before comparing the digital display with the reading on the thermal indicator.

**DO NOT OPEN THE CABINET DOOR(S)
DURING THE TEMPERATURE
STABILIZATION PERIOD.**

If the reading on the thermal indicator does not match the digital display, there may be a problem with the air sensor. See troubleshooting guide on page 7 of this manual; or call the factory service department for advice.



CAUTION

**DISCONNECT UNIT FROM
POWER SOURCE BEFORE
CLEANING OR SERVICING.**

SERVICE VIEW

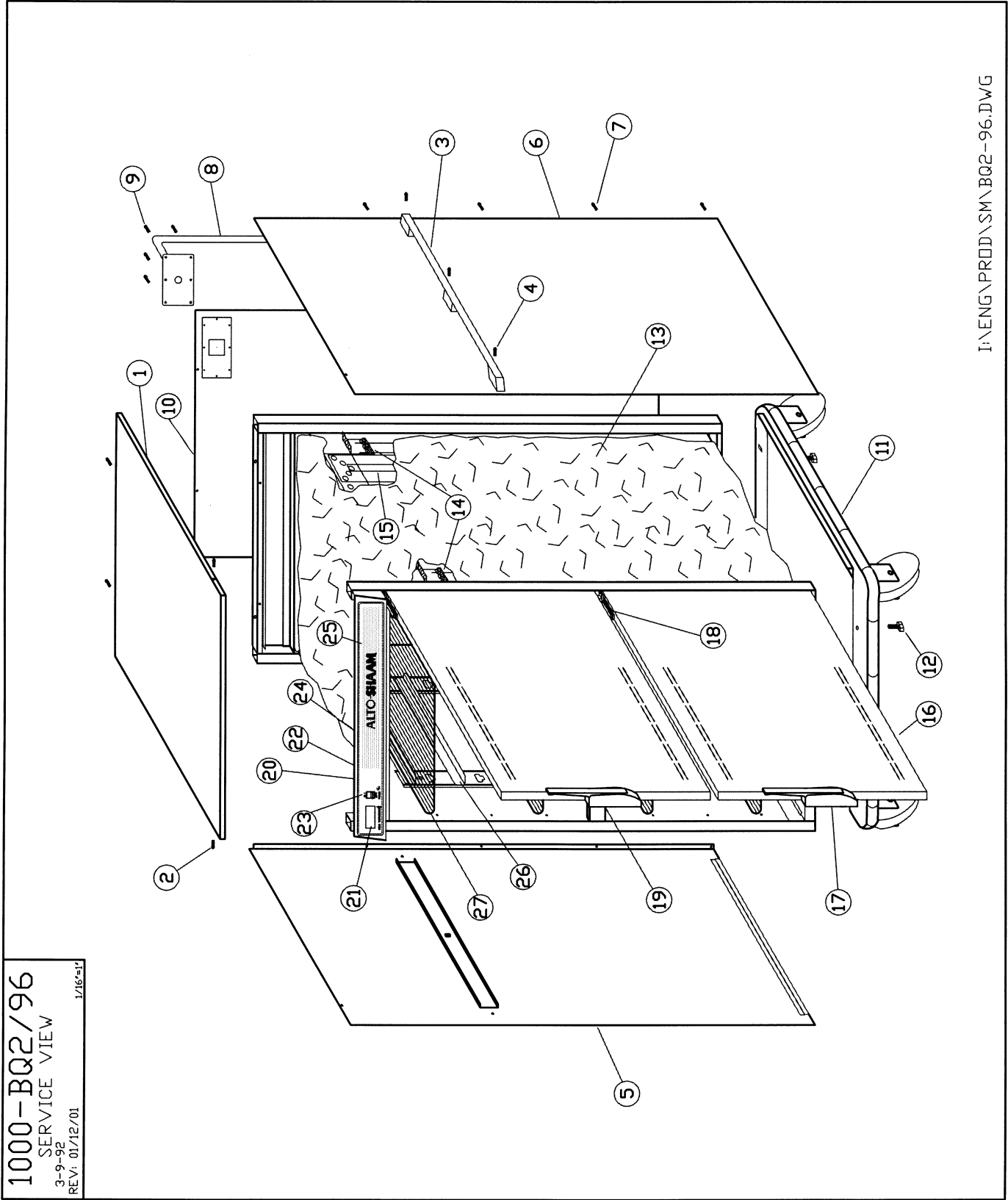

1000-BQ2/96
 SERVICE VIEW
 3-9-92
 REV: 01/12/01
 1/16"=1"

I:\ENG\PROD\SM\BQ2-96.DWG

SERVICE VIEW PARTS LIST

1000-BQ2/96

5/20/03

PART DESCRIPTION	QUANTITY	ALTO-SHAAM	PART DESCRIPTION	QUANTITY	ALTO-SHAAM
	PER UNIT	PART NO.		PER UNIT	PART NO.
1. TOP	1	4948	17. DOOR HANDLE	2	HD-2566
2. TOP MOUNTING SCREWS	4	SC-2425	DOOR HANDLE MOUNTING SCREWS	8	SC-2073
3. PUSH HANDLE	2	HD-2861	DOOR CATCH MOUNTING SCREWS	4	SC-2070
4. PUSH HANDLE MOUNTING SCREWS	6	SC-2567	18. HINGES:		
5. CASING, LEFT-HAND	1	14462	TOP PIVOT HINGE	1	HG-2864
6. CASING, RIGHT-HAND	1	14463	CENTER/BOTTOM PIVOT HINGE	2	HG-2865
7. CASING MOUNTING SCREWS	4	SC-2425	TOP DOOR HINGE	2	HG-2863
CASING MOUNTING SCREWS	2	SC-2459	BOTTOM DOOR HINGE	2	HG-2862
8. CORDSET, 125V	1	CD-3232	HINGE MOUNTING SCREWS	12	SC-2072
CORDSET, 208-240V	1	CD-3551	HINGE BUSHINGS	4	BU-2722
CORDSET, 230V	1	CD-3922	TOP & CENTER HINGE MOUNTING SCREWS	1	SC-25004
9. CORD PLATE MOUNTING SCREWS	6	SC-2459	19. SENSOR	1	SN-33540
10. CASING, BACK	1	11500	SENSOR REPLACEMENT KIT	1	14785
CASING BACK MOUNTING SCREWS	2	SC-2425	METAL SENSOR GUARD	1	13047
11. BOTTOM BUMPER ASSEMBLY	1	14980	TEFLON MOUNTING BLOCK	1	BK-22636
BUMPER, RUBBER, 10' (3048mm)	1	BM-24766	BLOCK MOUNTING SCREWS	2	SC-2352
BUMPER FRAME	1	BM-24950	20. SOLID STATE RELAY	1	RL-3736
CASTERS, RIGID	2	CS-2042	HEAT SINK	1	HE-23421
CASTERS, SWIVEL WITH BRAKE	2	CS-2231	21. THERMOSTAT	1	TT-33563
12. BUMPER ASSEMBLY MOUNTING BOLTS	4	SC-2191	22. TRANSFORMER, 125V	1	TN-3972
BUMPER ASSEMBLY MOUNTING WASHERS	4	WS-23725	TRANSFORMER, 208-240V, 230V	1	TN-3935
BUMPER ASSEMBLY MOUNTING WASHERS	4	WS-2867	23. POWER SWITCH	1	SW-3887
13. INSULATION:			FILTER, 230V ONLY	1	FI-33225
25-1/2" x 73' (648mm x 22250mm)	1.5	IN-22364	24. FUSE, 1 AMP, 208-240V, 230V	2	FU-33097
14. CABLE CONNECTION HARDWARE			FUSEHOLDER, 208-240V, 230V	1	FU-3772
15. HEATING CABLE			25. CONTROL PANEL OVERLAY	1	PE-23820
125V: 126' (38405mm)	1	CB-3045	26. SHELF SLIDE	8	1061
208-240V: 189' (57607mm)	1	CB-3045	SHELF CLIP (NOT SHOWN)	4	11533
16. DOOR	2	5677	27. SHELVES	4	SH-2835
DOOR GASKET [each door] 10' (3048mm)	1	GS-2398			

Cable Heating Replacement

Service Kit (208-240V)

No. 4881

includes:

CB-3045	Cable Heating Element	.210 feet
CR-3226	Ring Connector	.12
IN-3488	Insulation Corner	.1 foot
BU-3105	Shoulder Bushing	.12
BU-3106	Cup Bushing	.12
SL-3063	Insulating Sleeve	.12
TA-3540	High Temperature Electrical Tape	.1 roll
ST-2439	10.32 Stud	.12
NU-2215	Hex Nut	.24

Cable Heating Replacement

Service Kit (125V)

No. 4880

includes:

CB-3045	Cable Heating Element	.134 feet
CR-3226	Ring Connector	.4
IN-3488	Insulation Corner	.1 foot
BU-3105	Shoulder Bushing	.12
BU-3106	Cup Bushing	.4
SL-3063	Insulating Sleeve	.4
TA-3540	High Temperature Electrical Tape	.1 roll
ST-2439	10.32 Stud	.4
NU-2215	Hex Nut	.8



SERVICE VIEW

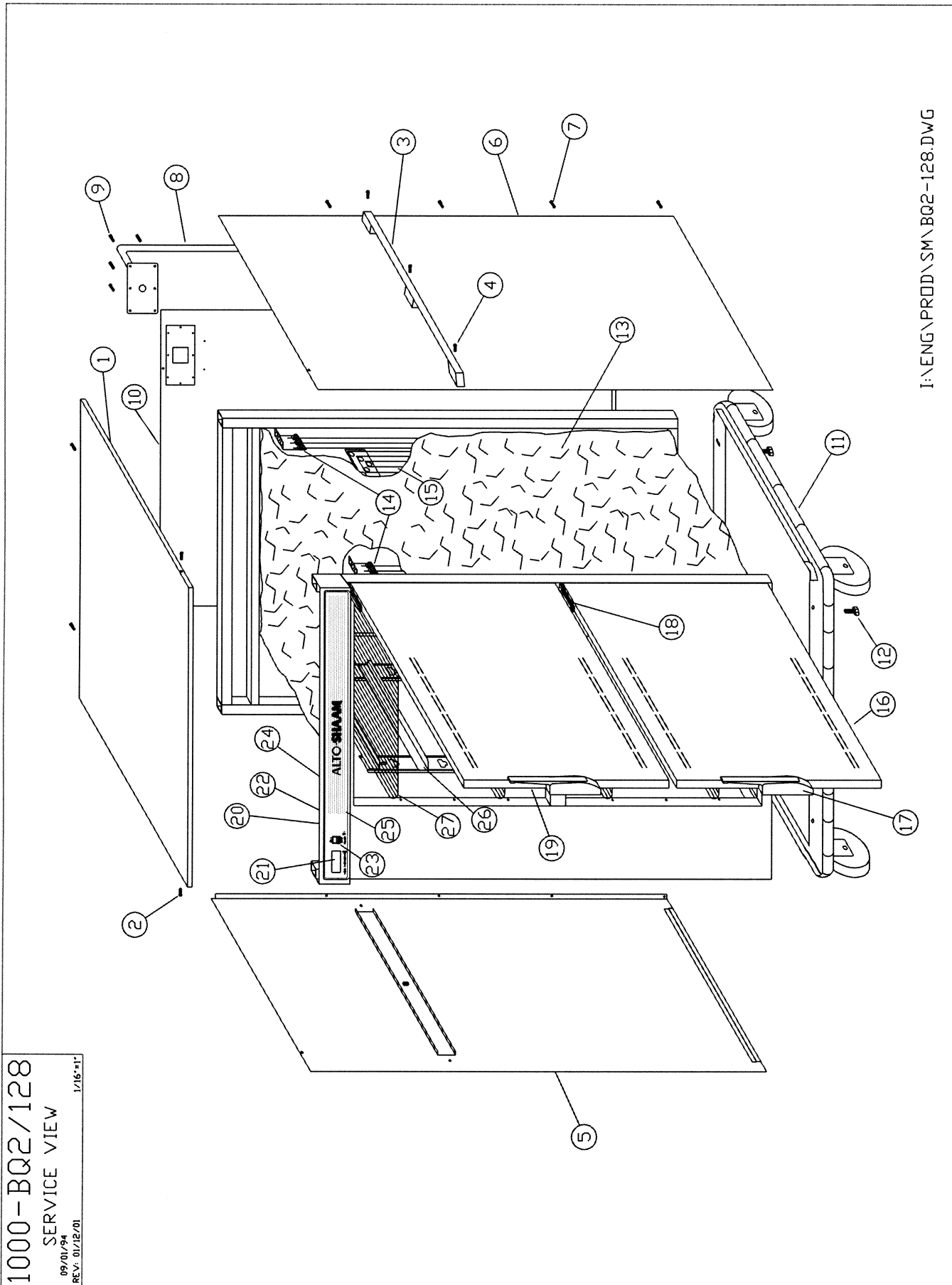

I:\ENG\PRODD\SM\BQ2-128.DWG

1000-BQ2/128
 SERVICE VIEW
 09/01/94
 REV. 01/12/01
 1/16"=1'

SERVICE VIEW PARTS LIST

1000-BQ2/128

5/20/03

PART DESCRIPTION	QUANTITY ALTO-SHAAM		PART DESCRIPTION	QUANTITY ALTO-SHAAM	
	PER UNIT	PART NO.		PER UNIT	PART NO.
1. TOP	1	14004	17. DOOR HANDLE	2	HD-2566
2. TOP MOUNTING SCREWS	4	SC-2425	DOOR HANDLE MOUNTING SCREWS	8	SC-2073
3. PUSH HANDLE	2	HD-2861	DOOR CATCH MOUNTING SCREWS	4	SC-2070
4. PUSH HANDLE MOUNTING SCREWS	6	SC-2567	18. HINGES:		
5. CASING, LEFT-HAND	1	14462	TOP PIVOT HINGE	1	HG-2864
6. CASING, RIGHT-HAND	1	14463	CENTER/BOTTOM PIVOT HINGE	2	HG-2865
7. CASING MOUNTING SCREWS	4	SC-2425	TOP DOOR HINGE	2	HG-2863
CASING MOUNTING SCREWS	2	SC-2459	BOTTOM DOOR HINGE	2	HG-2862
8. CORD, 125V	1	CD-3397	HINGE MOUNTING SCREWS	12	SC-2072
CORD, 208-240V	1	CD-3551	HINGE BUSHINGS	4	BU-2722
CORDSET, 230V	1	CD-3922	TOP & CENTER HINGE MOUNTING SCREWS	1	SC-25004
9. CORD PLATE MOUNTING SCREWS	6	SC-2459	19. SENSOR	1	SN-33540
10. CASING, BACK	1	12169	SENSOR REPLACEMENT KIT	1	14785
CASING BACK MOUNTING SCREWS	2	SC-2425	METAL SENSOR GUARD	1	13047
11. BOTTOM BUMPER ASSEMBLY	1	14982	TEFLON MOUNTING BLOCK	1	BK-22636
BUMPER, RUBBER, 12' (3658mm)	1	BM-24766	BLOCK MOUNTING SCREWS	2	SC-2352
BUMPER FRAME	1	BM-24951	20. SOLID STATE RELAY	1	RL-3736
CASTERS, RIGID	2	CS-2042	HEAT SINK	1	HE-23421
CASTERS, SWIVEL WITH BRAKE	2	CS-2231	21. THERMOSTAT	1	TT-33563
12. BUMPER ASSEMBLY MOUNTING BOLTS	4	SC-2191	22. TRANSFORMER, 125V	1	TN-3972
BUMPER ASSEMBLY MOUNTING WASHERS	4	WS-23725	TRANSFORMER, 208-240V, 230V	1	TN-3935
BUMPER ASSEMBLY MOUNTING WASHERS	4	WS-2867	23. POWER SWITCH	1	SW-3887
13. INSULATION:			FILTER, 230V only	1	FI-33225
25-1/2" x 73' (648mm x 22250mm)	1.5	IN-22364	24. FUSE, 1 AMP, 208-240V, 230V	2	FU-33097
14. CABLE CONNECTION HARDWARE			FUSEHOLDER, 208-240V, 230V	1	FU-3772
15. HEATING CABLE: 318' (96926mm)	1	CB-3045	25. CONTROL PANEL OVERLAY	1	PE-22830
16. DOOR	2	5677	26. SHELF SLIDE	8	1061
DOOR GASKET [each door] 10' (3048mm)	1	GS-2398	SHELF CLIP (NOT SHOWN)	4	11533
			27. SHELVES	4	SH-22727



CAUTION

**DISCONNECT UNIT FROM
POWER SOURCE BEFORE
CLEANING OR SERVICING.**

***Three are needed to replace
the cable in this banquet cart.***

Cable Heating Replacement

Service Kit

No. 4879

<small>includes:</small>	
CB-3045	Cable Heating Element112 feet
CR-3226	Ring Connector6
IN-3488	Insulation Corner1 foot
BU-3105	Shoulder Bushing6
BU-3106	Cup Bushing6
SL-3063	Insulating Sleeve6
TA-3540	High Temperature Electrical Tape1 roll
ST-2439	Stud 10.326
NU-2215	Hex Nut12



SERVICE VIEW

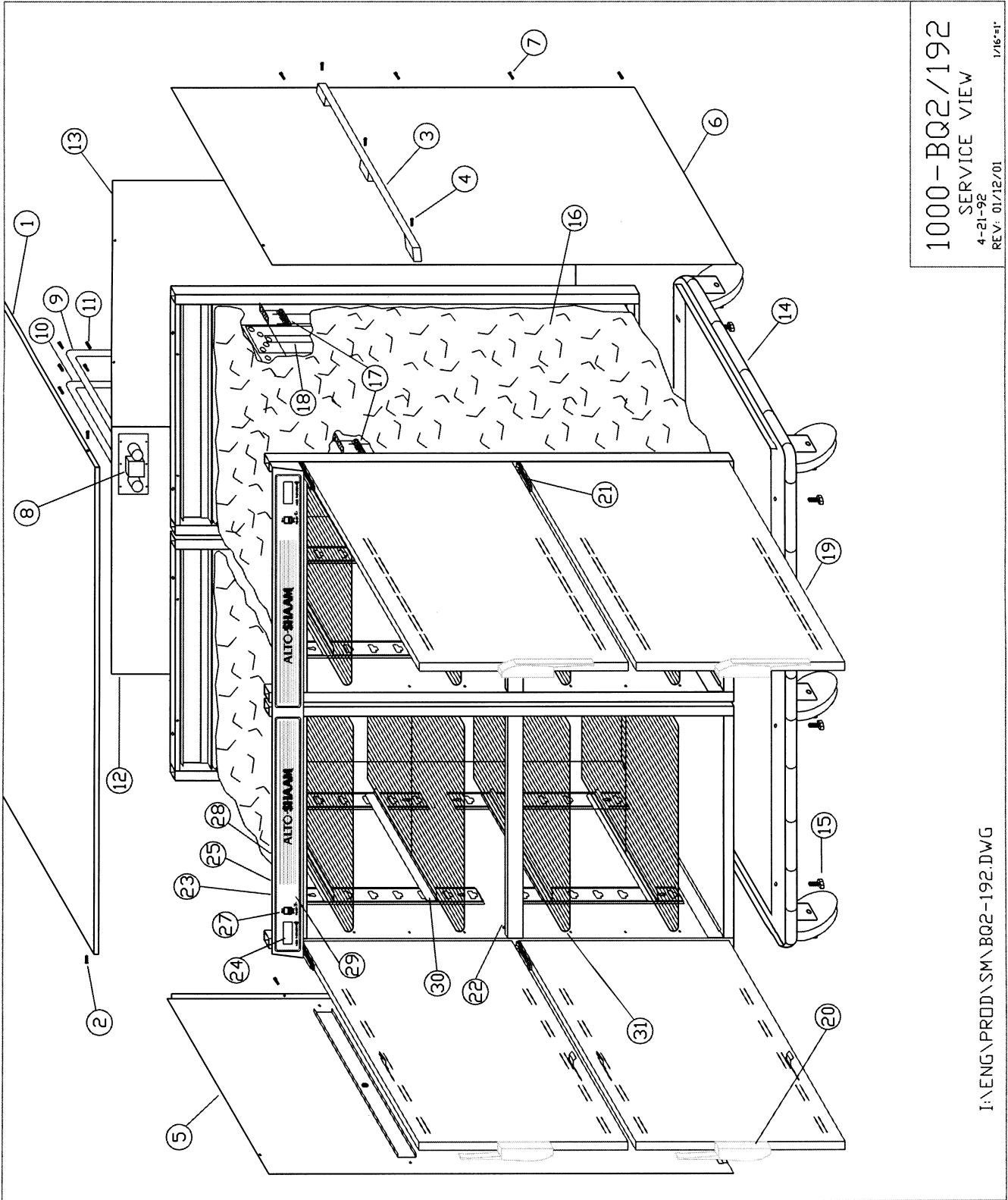

SERVICE VIEW PARTS LIST

1000-BQ2/192

5/20/03 PART DESCRIPTION	QUANTITY PER UNIT	ALTO-SHAAM PART NO.	PART DESCRIPTION	QUANTITY PER UNIT	ALTO-SHAAM PART NO.
1. TOP	1	4955	19. DOOR	4	5677
2. TOP MOUNTING SCREWS	6	SC-2425	DOOR GASKET [each door] — 10' (3048mm)	1	GS-2398
3. PUSH HANDLE	2	HD-2861	20. DOOR HANDLE	4	HD-2566
4. PUSH HANDLE MOUNTING SCREWS	6	SC-2567	DOOR HANDLE MOUNTING SCREWS	16	SC-2073
5. CASING, LEFT-HAND	1	14462	DOOR CATCH MOUNTING SCREWS	8	SC-2070
6. CASING, RIGHT-HAND	1	14463	21. HINGES:		
7. CASING MOUNTING SCREWS	6	SC-2425	TOP PIVOT HINGE	2	HG-2864
CASING MOUNTING SCREWS	2	SC-2459	CENTER/BOTTOM PIVOT HINGE	4	HG-2865
8. POWER SWITCH (125V ONLY) (HI/LOW)	1	SW-3617	TOP DOOR HINGE	4	HG-2863
9. CORDSET, 30 AMP, 125V	1	CD-33366	BOTTOM DOOR HINGE	4	HG-2862
INLET, 125V, 30 AMP	1	IT-3306	HINGE MOUNTING SCREWS	26	SC-2072
CORD, 208-240V	1	CD-3551	HINGE BUSHINGS	8	BU-2722
CORDSET, 230V	1	CD-3922	TOP & CENTER HINGE MOUNTING SCREWS	2	SC-25004
10. CORD, 20 AMP, 125V ONLY	1	CD-3397	22. SENSOR	1	SN-33540
INLET, 125V, 20 AMP	1	IT-3723	SENSOR REPLACEMENT KIT	2	14785
11. CORD PLATE MOUNTING SCREWS	6	SC-2459	METAL SENSOR GUARD	2	13047
12. CASING BACK, LEFT-HAND, 125V	1	11617	TEFLON MOUNTING BLOCK	2	BK-22636
CASING BACK, LEFT-HAND, 208-240V	1	11500	BLOCK MOUNTING SCREWS	4	SC-2352
13. CASING BACK, RIGHT-HAND	1	11501	23. SOLID STATE RELAY	2	RL-3736
CASING BACK MOUNTING SCREWS	8	SC-2425	HEAT SINK	2	HE-23421
14. BOTTOM BUMPER ASSEMBLY	1	14983	24. THERMOSTAT	2	TT-33563
BUMPER, RUBBER, 16' (4877mm)	1	BM-24766	25. TRANSFORMER, 125V	2	TN-3972
BUMPER FRAME	1	BM-24920	TRANSFORMER, 208-240V, 230V	2	TN-3935
CASTERS, RIGID	2	CS-2042	27. POWER SWITCH	2	SW-3887
CASTERS, SWIVEL WITH BRAKE	4	CS-2231	FILTER, 230V only	2	FI-33225
15. BUMPER ASSEMBLY MOUNTING BOLTS	8	SC-2191	28. FUSE, 1 AMP, 208-240V, 230V	4	FU-33097
BUMPER ASSEMBLY MOUNTING WASHERS	4	WS-23725	FUSEHOLDER, 208-240V, 230V	2	FU-3772
BUMPER ASSEMBLY MOUNTING WASHERS	4	WS-2867	29. CONTROL PANEL OVERLAY		
16. INSULATION: 25-1/2" x 73' 648mm x 22250mm)	3	IN-22364	— LEFT-HAND	1	PE-23820
17. CABLE CONNECTION HARDWARE			— RIGHT-HAND	1	PE-23821
18. HEATING CABLE, 125V: 252' (76810mm)	1	CB-3045	30. SHELF SLIDE	16	1061
208-240V: 378' (115214mm)	1	CB-3045	SHELF CLIPS (NOT SHOWN)	8	11533
			31. SHELVES	8	SH-2835

Cable Heating Replacement Kit (208-240V) each side

No. 4881

<small>includes:</small>	
CB-3045	Cable Heating Element210 feet
CR-3226	Ring Connector12
IN-3488	Insulation Corner1 foot
BU-3105	Shoulder Bushing12
BU-3106	Cup Bushing12
SL-3063	Insulating Sleeve12
TA-3540	High Temperature Electrical Tape1 roll
ST-2439	10.32 Stud12
NU-2215	Hex Nut24

Cable Heating Replacement Kit (125V) each side

No. 4880

<small>includes:</small>	
CB-3045	Cable Heating Element.134 feet
CR-3226	Ring Connector4
IN-3488	Insulation Corner.1 foot
BU-3105	Shoulder Bushing12
BU-3106	Cup Bushing4
SL-3063	Insulating Sleeve.4
TA-3540	High Temperature Electrical Tape.1 roll
ST-2439	10.32 Stud4
NU-2215	Hex Nut8



125V, 50-60HZ
1600W, 12.8A

ELECTRONIC THERMOSTAT
(TT-33563)

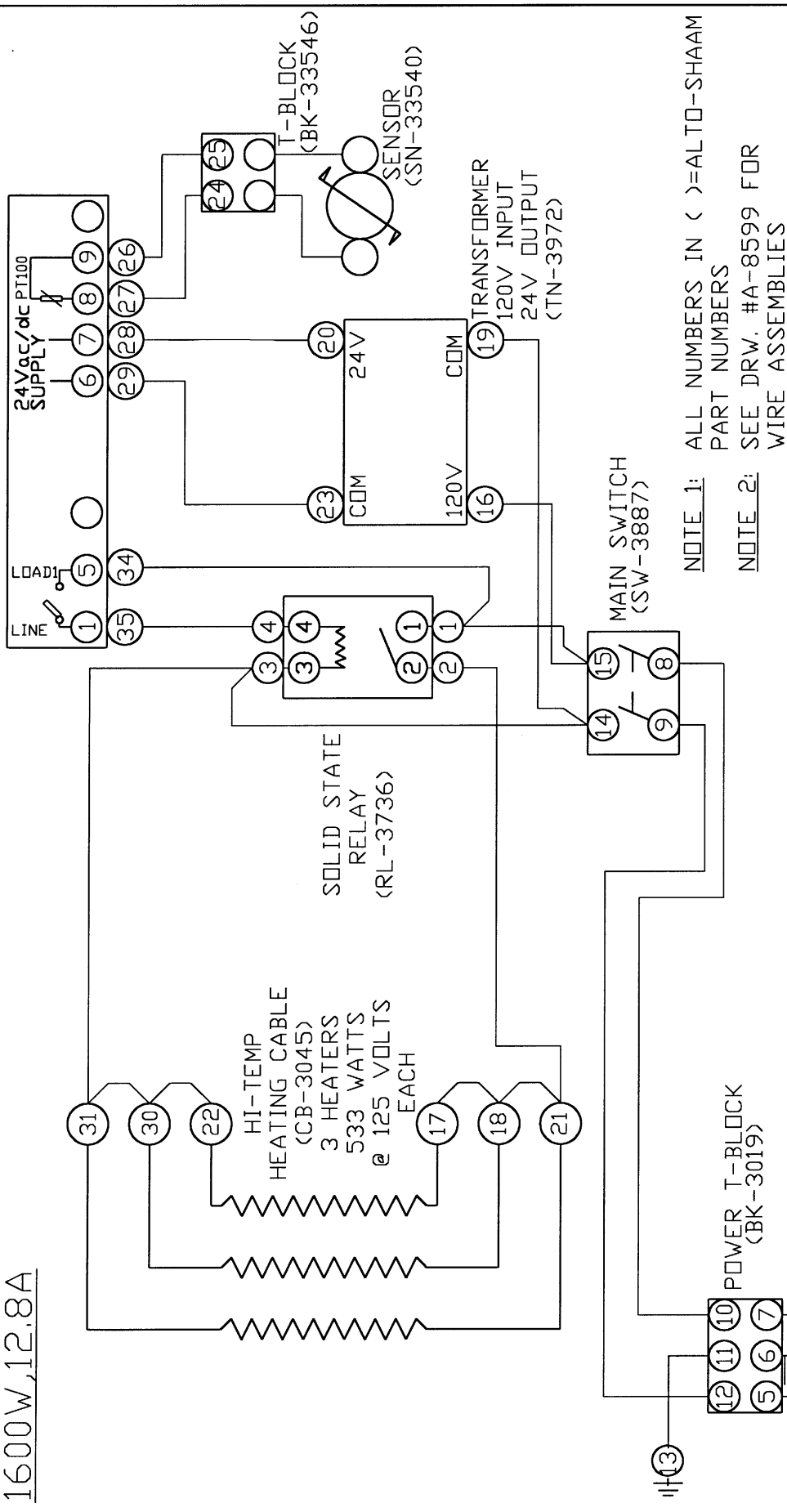

NOTE 1: ALL NUMBERS IN ()=ALTO-SHAAM PART NUMBERS
NOTE 2: SEE DRW. #A-8599 FOR WIRE ASSEMBLIES

REVISIONS		1000-BQ2/96		125V	
NO.	DATE	BY			
1	04/11/91	ALD			
2	08/06/97	RS			
3	09/10/99	JMM			
4	04/26/00	NW/M			
5					

WIRING DIAGRAM

ALTO-SHAAM INC.
MEMONONE FALLS, WISCONSIN

DRAWN BY	ALD	SCALE	1"=1"	DWG. NO.	
APP'D	MS	DATE	2-22-88		A-7303

ELECTRONIC THERMOSTAT
(TT-33563)

208-240V, 50-60HZ
@208V= 1200W, 5,9A
@240V= 1600W, 7.0A

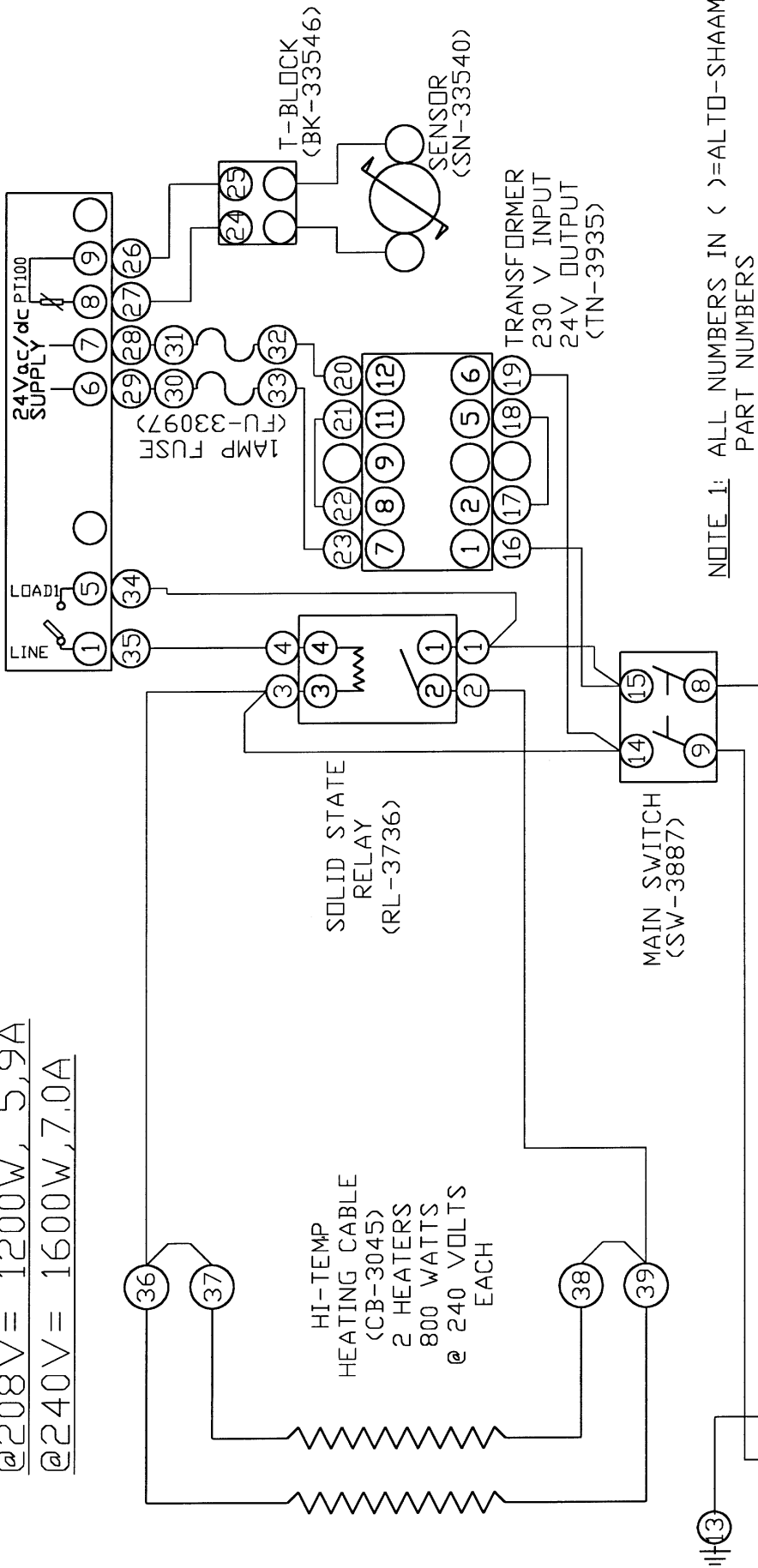

NOTE 1: ALL NUMBERS IN () = ALTO-SHAAM PART NUMBERS

NOTE 2: SEE DRW. #A-8600 FOR WIRE ASSEMBLIES

REVISIONS		1000-BQ2/96		208-240V	
NO.	DATE	BY			
1	07/17/90	ALD			
2	12/01/92	LRW			
3	11/10/93	RS			
4	08/06/97	RS			
5	09/10/99	JMM	MS	APP'D	
6	04/26/00	NW	MS	APP'D	

WIRING DIAGRAM

ALTO-SHAAM INC.
MENOMONEE FALLS, WISCONSIN

14/3 CORD SET
(CD-3551)

DRAWN BY ALD SCALE 1"=1" DWG. NO.
DATE 2/22/88 A-7304

ELECTRONIC THERMOSTAT
(TT-33563)

230V
50-60HZ
1500W
6.5A

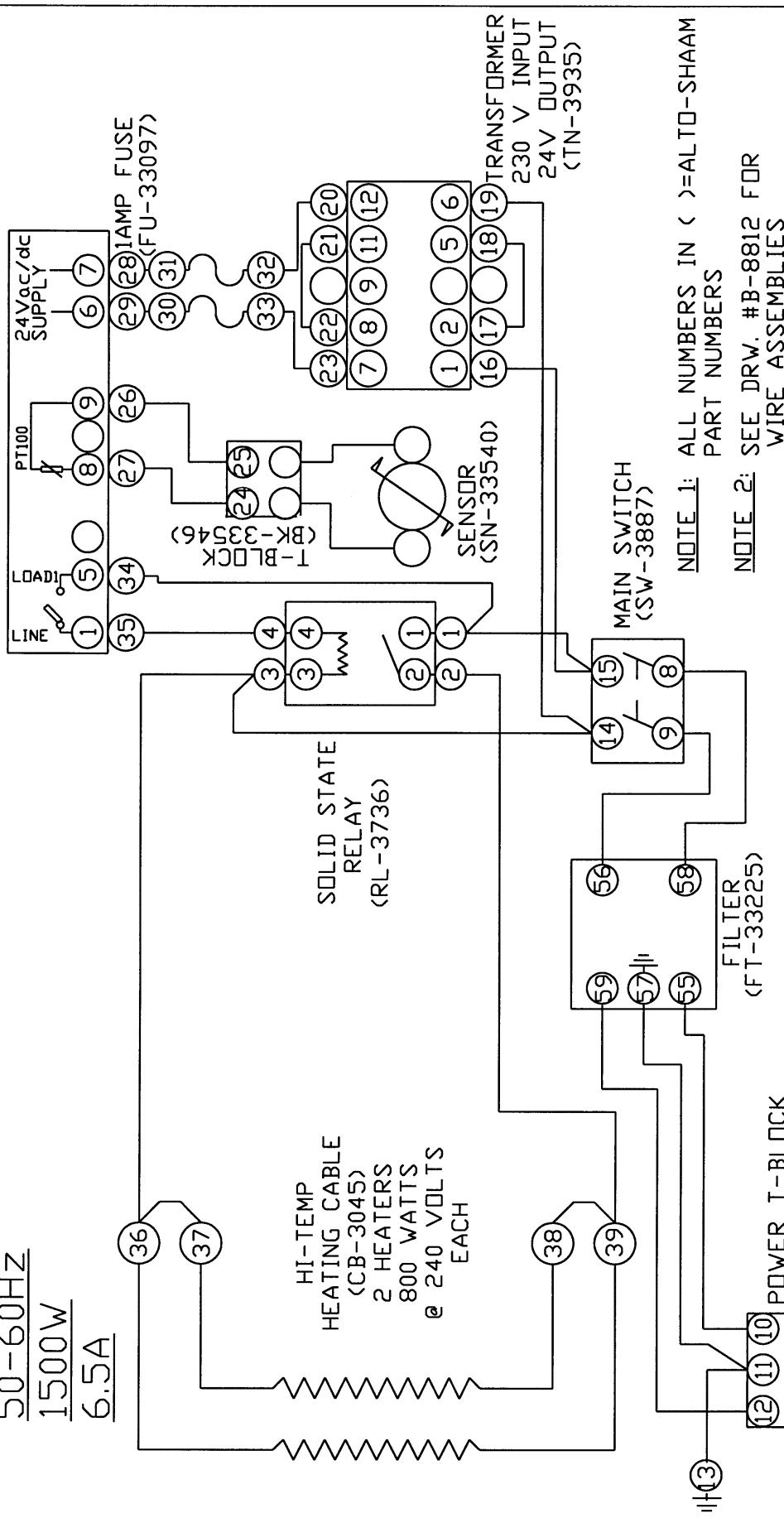

NOTE 1: ALL NUMBERS IN () = ALTO-SHAAM PART NUMBERS
NOTE 2: SEE DRW. #B-8812 FOR WIRE ASSEMBLIES

REVISIONS		1000-BQ2/96		230V INTL	
NO.	DATE	BY	RS	SCALE	DWG. NO.
1	11/10/93	RS		1"=1'	A-7344
2	08/06/97	RS			
3	09/10/99	JMM			
4	04/26/00	NW/W			
5	05/29/03	CJB	MS	DATE 12/01/92	

WIRING DIAGRAM

ALTO-SHAAM INC.
MENDONSEE FALLS, WISCONSIN

TYPE HD7 RN-F
16/3 CORDSET
(CD-3922)

ELECTRONIC THERMOSTAT
(TT-33563)

125 VOLTS, 50-60HZ
2300 WATTS
18.4 AMPS

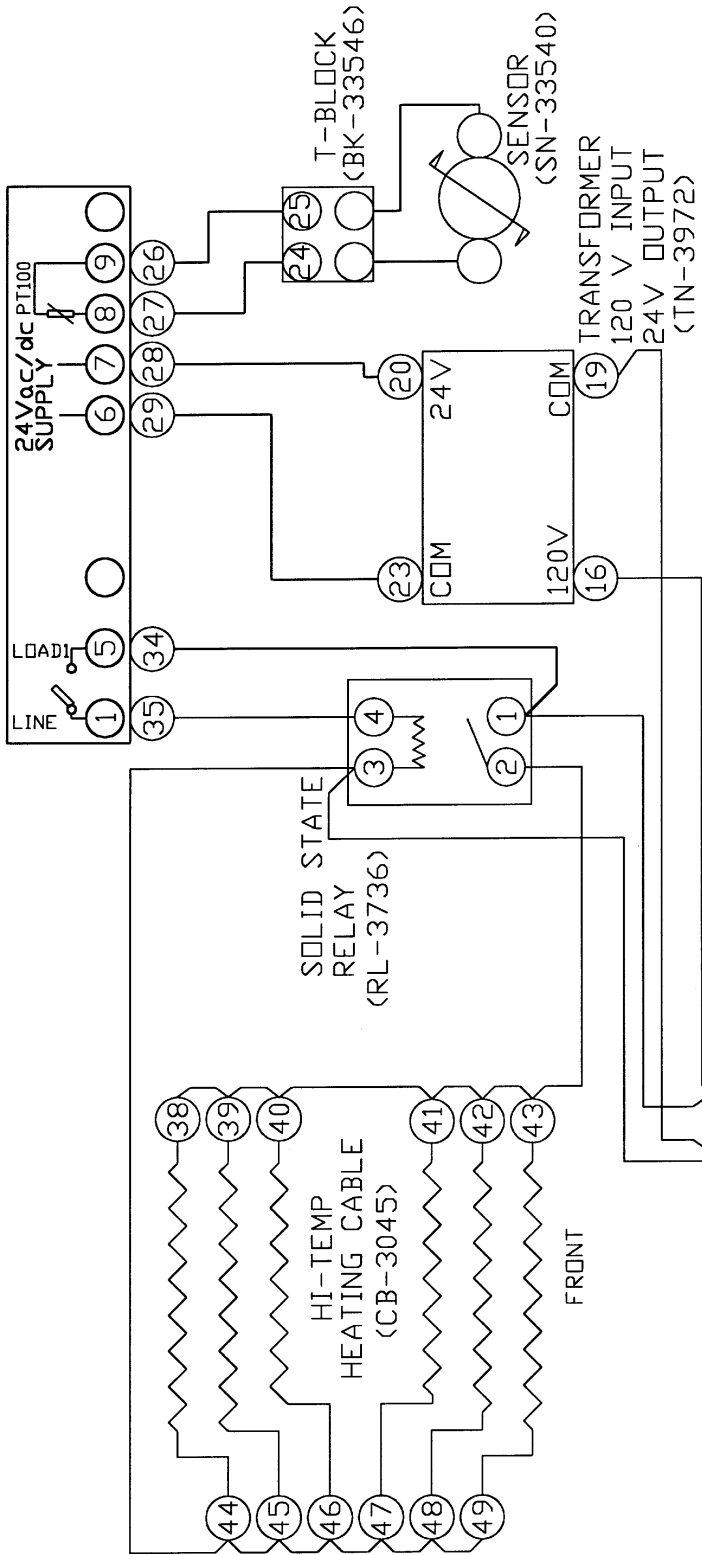

REVISIONS		1000-BQ2/128		(125V)
NO.	DATE	BY		
1	01/31/95	RS		
2	09/10/99	JMM		
3	03/01/00	MSM		
4	04/27/00	NW/W	DRAWN BY RS	SCALE 1"=1"
5			APP'D MS	DATE 08/31/94

WIRING DIAGRAM

ALTO-SHAAM INC.
MEMMONEE FALLS, WISCONSIN

DWG. NO. **A-7378**

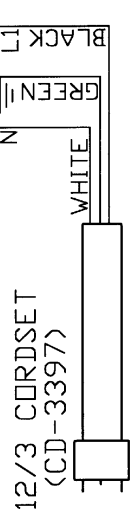

NOTE 1: ALL NUMBERS IN () = ALTO-SHAAM PART NUMBERS.
NOTE 2: SEE DRW. #C-8711 FOR WIRE ASSEMBLIES.

208-240V, 50-60HZ
 @208V = 1700W, 8.2A
 @240V = 2300W, 9.6A

ELECTRONIC THERMOSTAT
 (TT-33563)

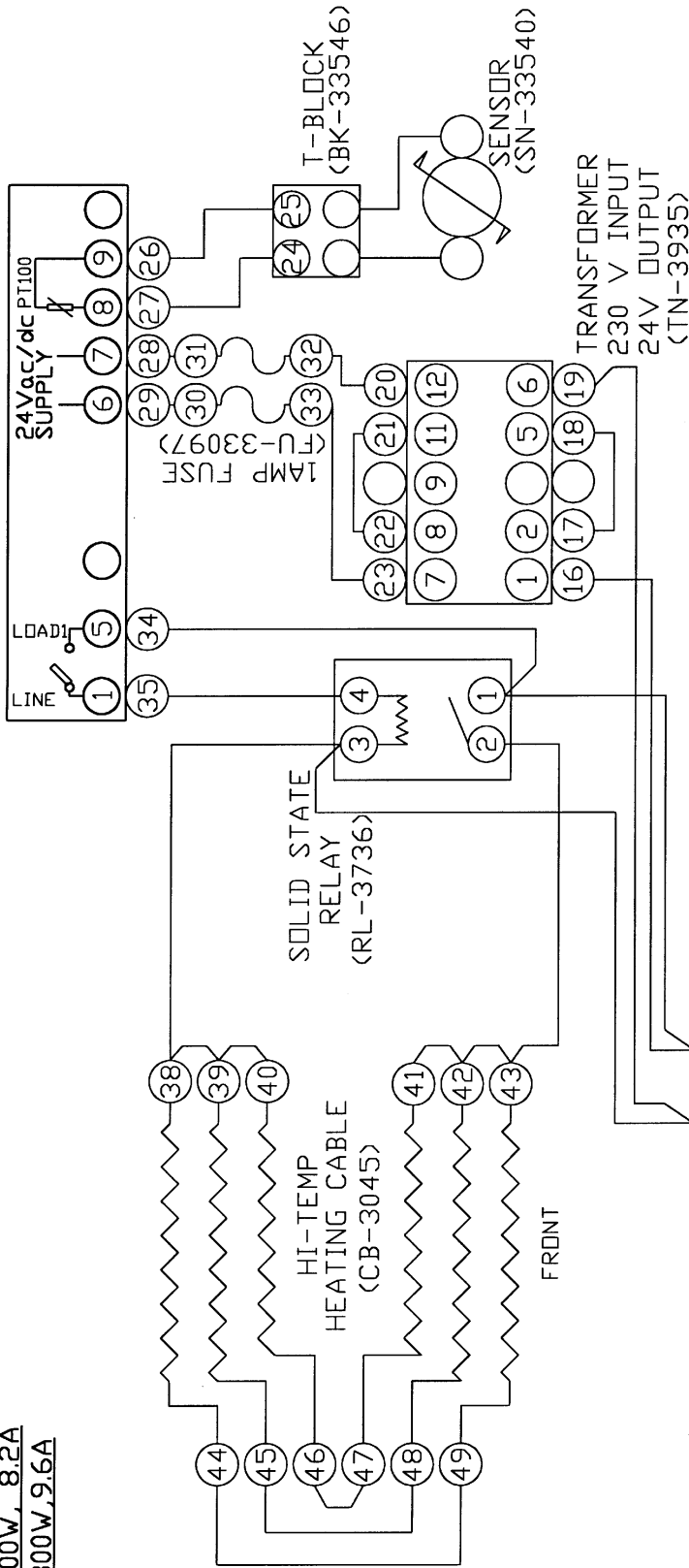

REVISIONS		1000-BQ2/128	(208-240V)
NO.	DATE	BY	
1	09/10/99	JMM	
2	04/27/00	N/W	
3			
4			
5			

WIRING DIAGRAM

ALTO-SHAAM INC.
 MENOMONEE FALLS, WISCONSIN

DRAWN BY	RS	SCALE	1"=1"	DWG. NO.	
APP'D	MS	DATE	08/31/94		A-7379

NOTE 1: ALL NUMBERS IN () = ALTO-SHAAM PART NUMBERS.
 NOTE 2: SEE DRW. #C-8712 FOR WIRE ASSEMBLIES.

ELECTRONIC THERMOSTAT
(TT-33563)

230V, 50-60HZ
2150 WATTS
9.3 AMPS

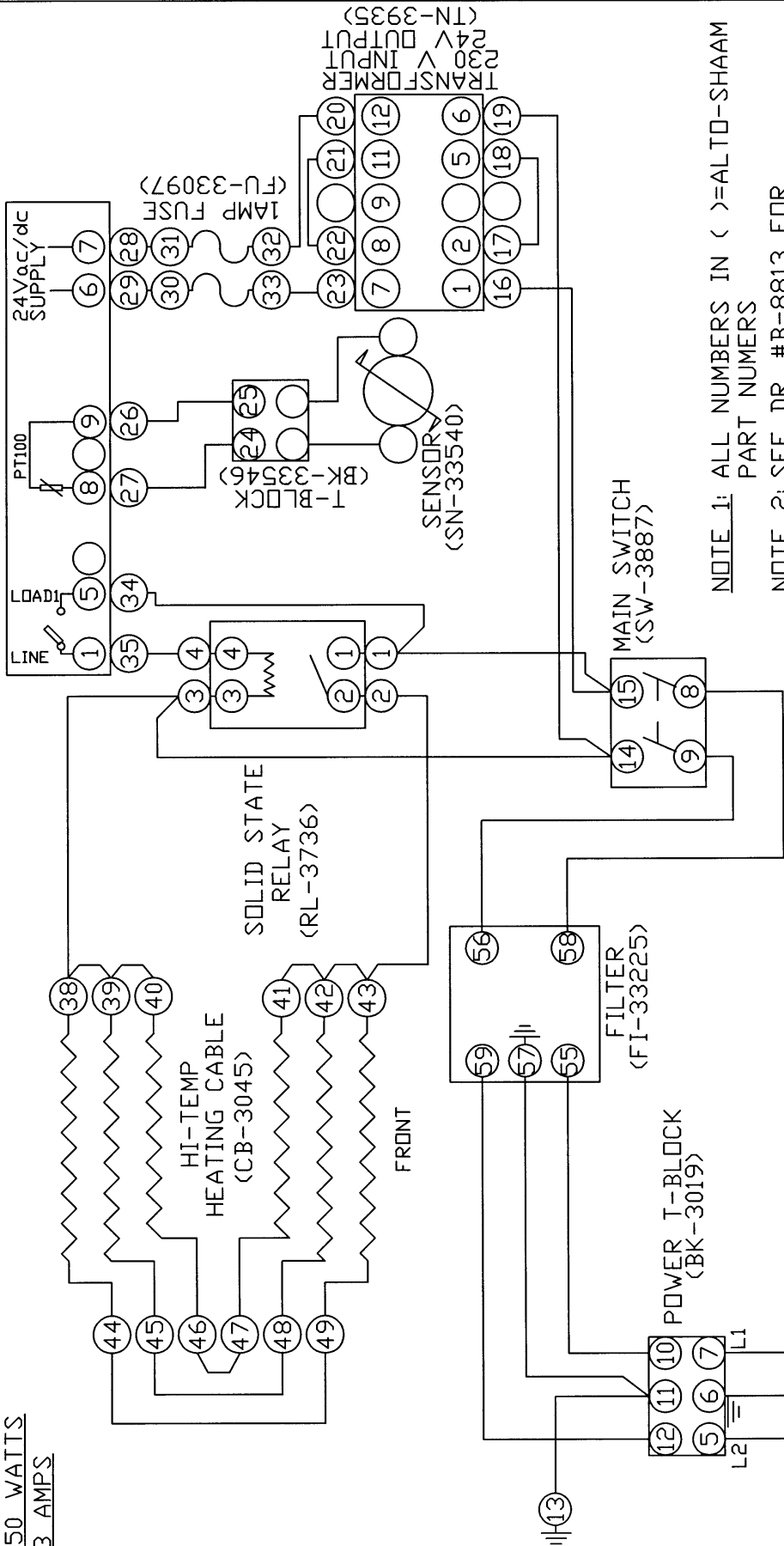

NOTE 1: ALL NUMBERS IN () = ALTO-SHAAM PART NUMBERS
NOTE 2: SEE DR. #B-8813 FOR WIRE ASSEMBLIES

REVISIONS		1000-BQ2/128		(230V)	
NO.	DATE	BY	RS	APP'D	MS
1	04/11/96	RS			
2	08/06/97	RS			
3	09/10/99	JMM			
4	04/27/00	NW			
5	05/29/03	CJB			

WIRING DIAGRAM

ALTO-SHAAM INC.
MEMONEE FALLS, WISCONSIN

16/3 CORDSET
TYPE (H07 RN-F)
(CD-3922)

DRAWN BY RS
SCALE 1"=1"

DATE 8/31/94

DWG. NO. A-7380

125V.A.C., 50-60Hz, 1ph
 POWER SWITCH IN LOW POSITION
 2000 Watts, 16.0 Amps
 POWER SWITCH IN HIGH POSITION
 3000 Watts, 24.0 Amps (max.)

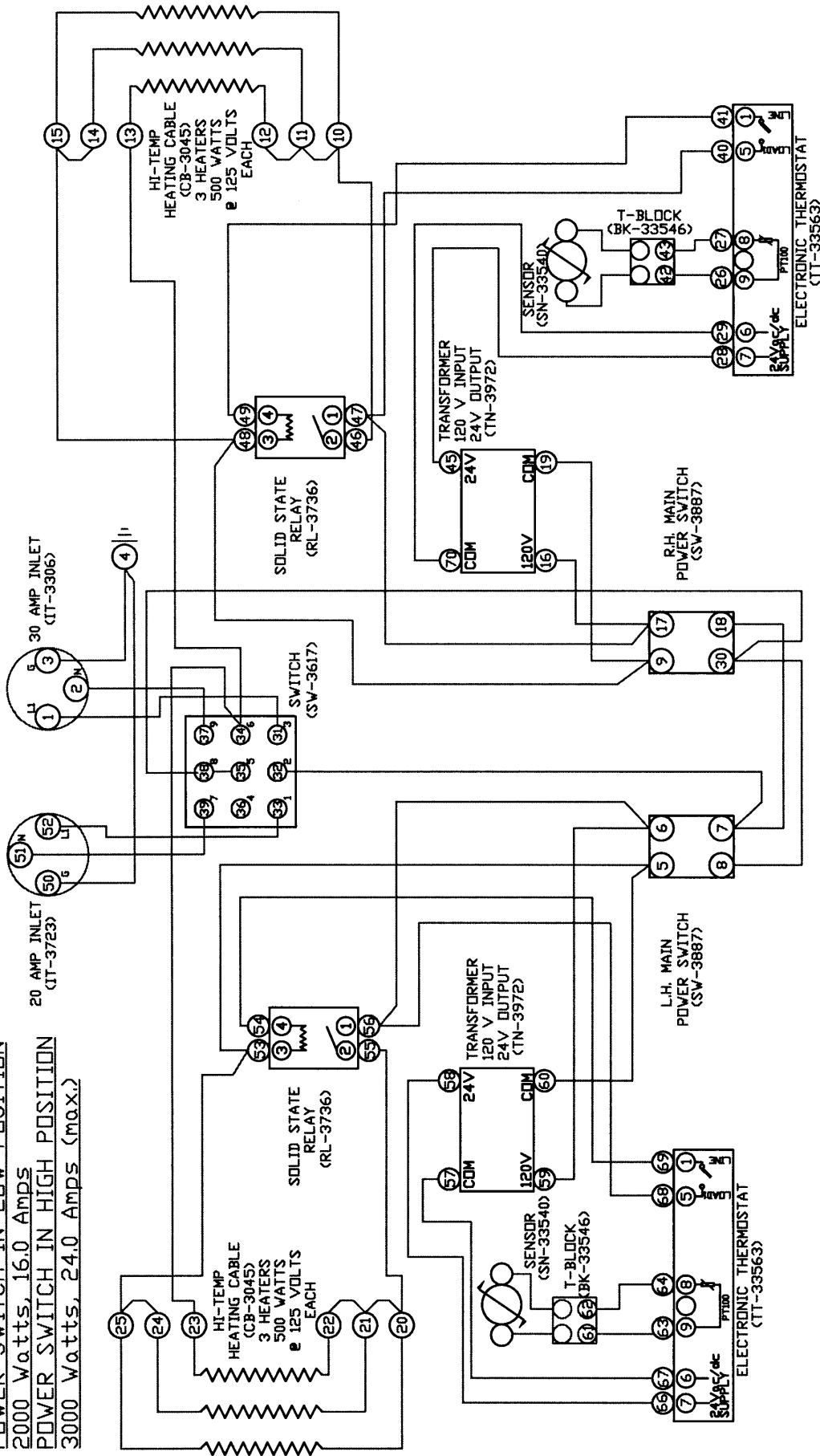

1000-802/192	125V
WIRING DIAGRAM	
09/30/88 ALO	03/22/90 ALO
05/26/92 ALO	08/06/97 RS
09/10/99 JMM	04/27/00 NVM
MS	MS
ALD	ALD
NONE	NONE
2/22/88 A-7305	

NOTE 1: ALL NUMBERS IN () = ALTO-SHAAM PART NUMBERS
 NOTE 2: SEE DRV. #B-8601 FOR WIRE ASSEMBLIES

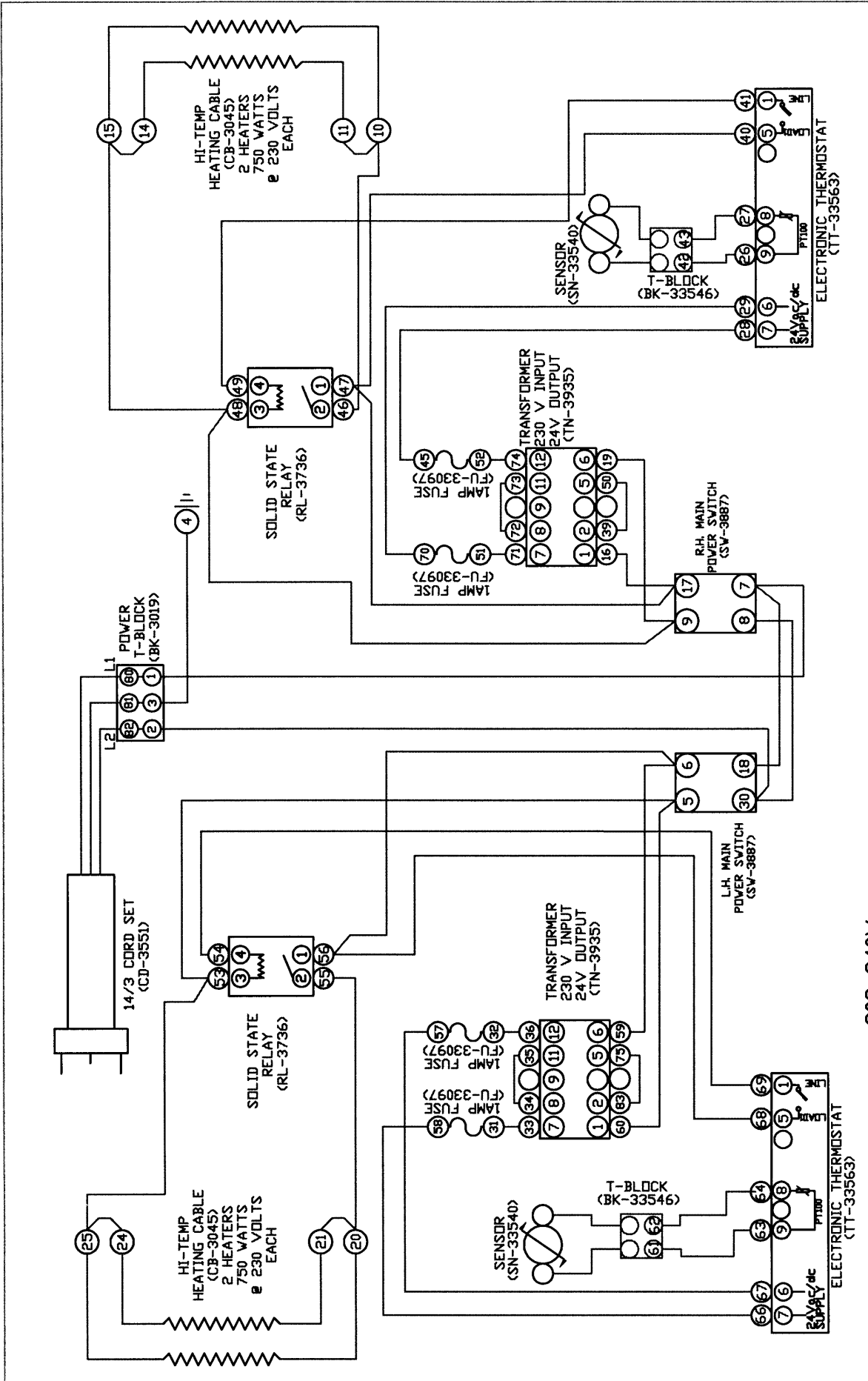

1000-BG/192 208-240V

WIRING DIAGRAM

REV	DATE	BY	CHK
07/17/90	ALD		
12/01/92	LRW		
11/10/93	RS		
08/06/97	RS		
09/10/99	JMM		

1"=1'

MS

2/22/88 A-7306

NOTE 1: ALL NUMBERS IN () = ALTO-SHAAM PART NUMBERS

NOTE 2: SEE DRW. #B-8602 FOR WIRE ASSEMBLIES

208-240V
50/60Hz
3400W
14.2A

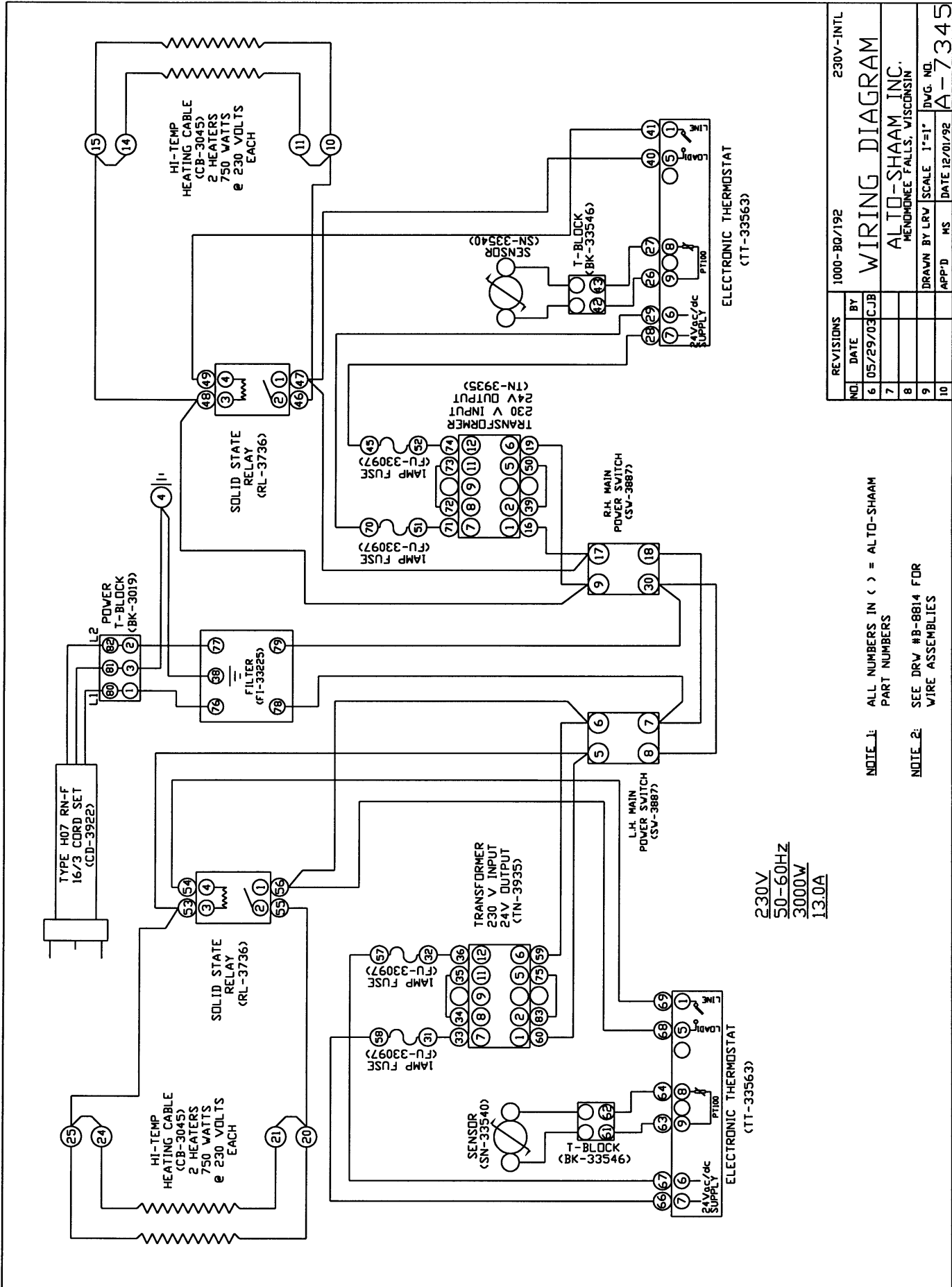

REVISIONS	NO.	DATE	BY
	6	05/29/03	CJB
	7		
	8		
	9		
	10		

1000-BQ/192

230V-INTL

WIRING DIAGRAM

ALTO-SHAAM INC.
MENDOTA FALLS, WISCONSIN

DRAWN BY LRW SCALE 1"=1" DWG. NO. A-7345

APP'D MS DATE 12/01/98

NOTE 1: ALL NUMBERS IN () = ALTO-SHAAM PART NUMBERS

NOTE 2: SEE DRW #B-8814 FOR WIRE ASSEMBLIES

230V
50-60HZ
3000W
13.0A

TRANSPORTATION DAMAGE and CLAIMS



LIMITED WARRANTY



All Alto-Shaam equipment is sold F.O.B. shipping point, and when accepted by the carrier, such shipments become the property of the consignee.

Should damage occur in shipment, it is a matter between the carrier and the consignee. In such cases, the carrier is assumed to be responsible for the safe delivery of the merchandise, unless negligence can be established on the part of the shipper.

1. Make an immediate inspection while the equipment is still in the truck or immediately after it is moved to the receiving area. Do not wait until after the material is moved to a storage area.
2. Do not sign a delivery receipt or a freight bill until you have made a proper count and inspection of all merchandise received.
3. Note all damage to packages directly on the carrier's delivery receipt.
4. Make certain the driver signs this receipt. If he refuses to sign, make a notation of this refusal on the receipt.
5. If the driver refuses to allow inspection, write the following on the delivery receipt:
Driver refuses to allow inspection of containers for visible damage.
6. Telephone the carrier's office immediately upon finding damage, and request an inspection. Mail a written confirmation of the time, date, and the person called.
7. Save any packages and packing material for further inspection by the carrier.
8. Promptly file a written claim with the carrier and attach copies of all supporting paperwork.

We will continue our policy of assisting our customers in collecting claims which have been properly filed and actively pursued. We cannot, however, file any damage claims for you, assume the responsibility of any claims, or accept deductions in payment for such claims.

Alto-Shaam, Inc. warrants to the original purchaser that any original part that is found to be defective in material or workmanship will, at our option, subject to provisions hereinafter stated, be replaced with a new or rebuilt part.

The labor warranty remains in effect one (1) year from installation or fifteen (15) months from the shipping date, whichever occurs first.

The parts warranty remains in effect one (1) year from installation or fifteen (15) months from the shipping date, whichever occurs first.

Exceptions to the one year part warranty period are as listed:

- A. Halo Heat cook/hold ovens include a five (5) year parts warranty on the heating element. Labor will be covered under the terms of the standard warranty period of one (1) year or fifteen (15) months.
- B. Alto-Shaam Quickchillers include a five (5) year parts warranty on the refrigeration compressor. Labor will be covered under the terms of the standard warranty period of one (1) year or fifteen (15) months.

This warranty does not apply to:

1. Calibration
2. Replacement of light bulbs and/or the replacement of display case glass due to damage of any kind.
3. Equipment damage caused by accident, shipping, improper installation or alteration.
4. Equipment used under conditions of abuse, misuse, carelessness or abnormal conditions.
5. Any losses or damage resulting from malfunction, including loss of product or consequential or incidental damages of any kind.
6. Equipment modified in any manner from original model, substitution of parts other than factory authorized parts, removal of any parts including legs, or addition of any parts.

This warranty is exclusive and is in lieu of all other warranties, expressed or implied, including the implied warranties of merchantability and fitness for purpose. In no event shall the Company be liable for loss of use, loss of revenue, or loss of product or profit, or for indirect or consequential damages. This warranty is in lieu of all other warranties expressed or implied and Alto-Shaam, Inc. neither assumes or authorizes any persons to assume for it any other obligation or liability in connection with Alto-Shaam equipment.

ALTO-SHAAM, INC.

Warranty effective January 1, 2000

RECORD THE MODEL AND SERIAL NUMBERS OF THE UNIT FOR EASY REFERENCE. ALWAYS REFER TO BOTH MODEL AND SERIAL NUMBERS IN ANY CONTACT WITH ALTO-SHAAM REGARDING THE UNIT.

Model: _____
Voltage: _____
Serial Number: _____

Date Installed: _____
Purchased From: _____

W164 N9221 Water Street • P.O. Box 450 • Menomonee Falls, Wisconsin 53052-0450 • U.S.A.

PHONE: 262.251.3800

FAX: 262.251.7067 • 800.329.8744 U.S.A./CANADA

WEBSITE:

800.558.8744 USA/CANADA

262.251.1907 INTERNATIONAL

www.alto-shaam.com