

Specification, Installation and Operation Manual

Pro Series Woodson Contact Grill

Models:
W.GPC62SC, W.GPC61SC, W.GPC350

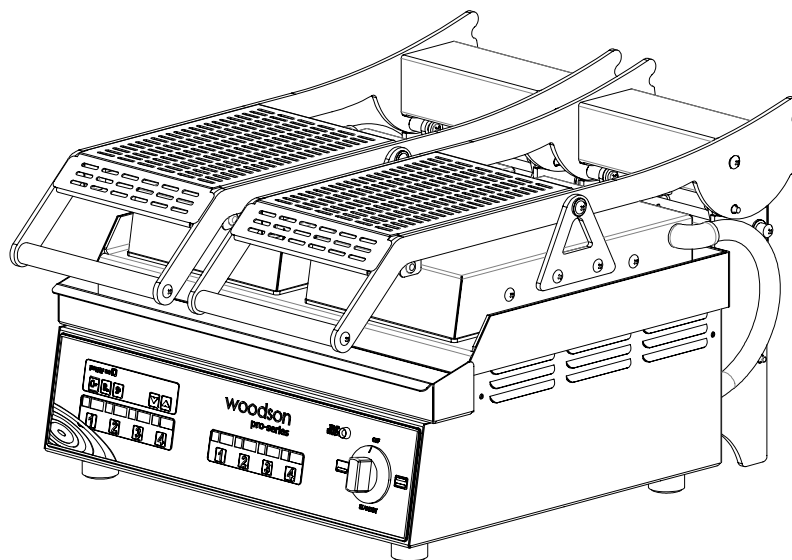

A guide on the use, care and maintenance
of your quality Woodson product

Rev: B - 27/07/2018

*innovative
solutions*



Phone: 0800 503 335
Spare Parts: 0800 503 503
www.southernhospitality.co.nz

Page Intentionally Left Blank

Introduction

Your New Woodson Product:3
Product Overview:3
Attention4
General Information4
<i>Service</i>	

Installation

Setting Up5
<i>Handling</i>	
<i>Unpacking</i>	
<i>Positioning</i>	
<i>Disposal</i>	
Electrical Connection6
<i>Information</i>	

Specification

Technical Specifications7
<i>W.GPC62SC</i>	
<i>W.GPC61SC</i>	
<i>W.GPC350</i>	

Operation

Operating Instructions10
<i>Operation (W.GPC61SC, W.GPC62SC)</i>	
<i>Operation (W.GPC350)</i>	
Cleaning12
<i>General Information</i>	
<i>Corrosion Protection</i>	
<i>Surface Finish</i>	
<i>Cleaning Schedule</i>	
<i>Materials Required</i>	
<i>Cleaning Procedure</i>	
<i>Cleaning Procedure - External Surfaces</i>	
Troubleshooting14

Your New Woodson Product:

Thank you for choosing this quality Woodson product. All our products are designed and made to meet the needs of food service professionals. By using, caring and maintaining your Woodson product according to these instructions, your Woodson product should give you many years of reliable service.

Stoddart is a wholly Australian owned company, which manufactures and distributes Woodson commercial catering equipment. Stoddart products are manufactured and/or engineered in Australia to provide excellent results whilst offering-value-for-money, ease-of-use and reliability.

Stoddart manufacture and distribute a comprehensive range of equipment for kitchens, food preparation and presentation.

Product Overview:

Configuration may vary according to model.

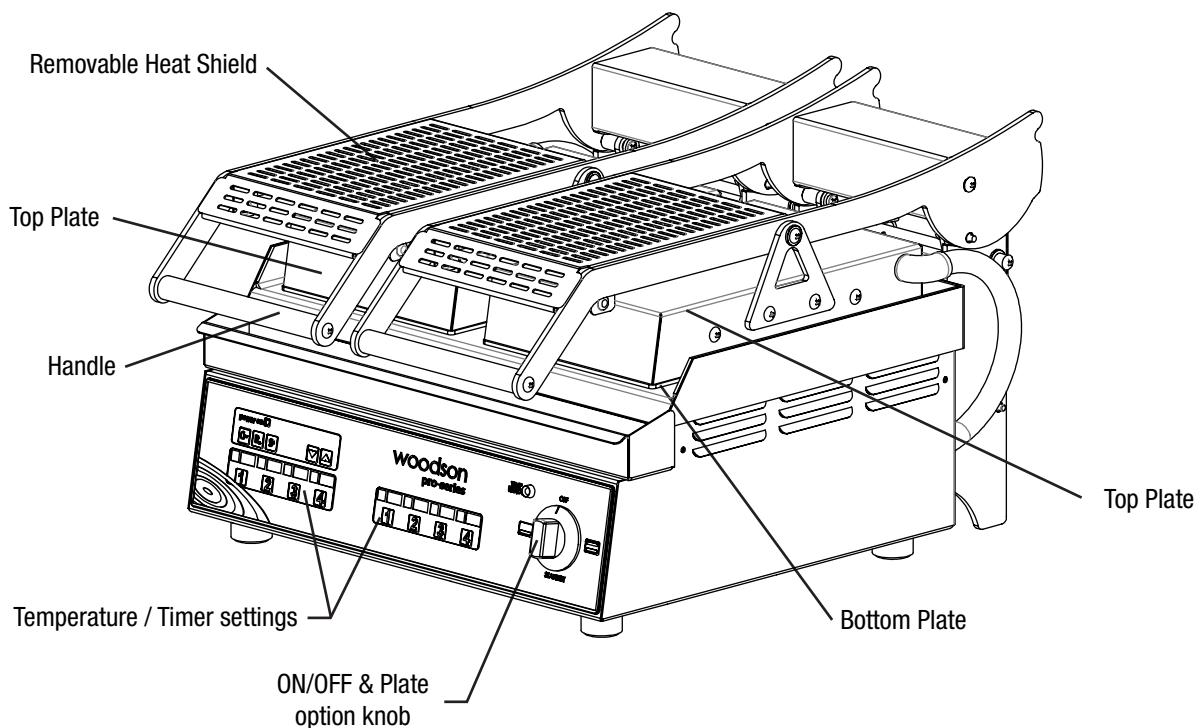
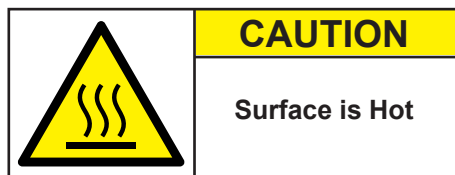

Attention

Carefully read this instruction booklet, as it contains important advice for safe installation, operation and maintenance. Keep this booklet on hand in a safe place for future reference by other operators or users.

Disclaimer

The manufacturer and distributor cannot be held responsible or liable for any injuries or damages of any kind occurred to persons, units or others, due to abuse and misuse of this unit in regards to installation, un-installation, operation, servicing or maintenance, or lack of conformity with the instructions indicated in this documentation.

All units made by the manufacturer are delivered assembled, where possible, and ready to install. Any installation, un-installation, servicing, maintenance and access or removal of any parts, panels or safety barriers that is not permitted, does not comply in accordance to this documentation, or not performed by a TRAINED AND AUTHORISED SPECIALIST will result in the IMMEDIATE LOSS OF THE WARRANTY.

The manufacturer cannot be held responsible or liable for any unauthorized modifications or repairs. All modifications or repairs must be approved by the manufacturer in writing before initiating. All modifications or repairs performed to this unit must be performed at all times by a TRAINED AND AUTHORISED SPECIALIST.

Stoddart design, manufacture & distribute Food Service Equipment (appliances) exclusively for the commercial market. This appliance is not designed nor intended for household or domestic use & must not be used for this purpose.

This product is intended for commercial use, and in line with Australian electrical safety standards the following warnings are provided:

- This product is not intended for use by persons (including children) with reduced physical, sensory or mental capabilities, or lack of experience and knowledge, unless they have been given supervision or instruction concerning the use of the product by a person responsible for their safety. Children should be supervised to ensure that they do not play with the product
- If the supply cord is damaged, it must be replaced by the manufacturer, its service agent or similarly qualified persons in order to avoid a hazard

General Information

When using any electrical unit, safety precautions must always be observed.

Our units have been designed for high performance. Therefore, the unit must be used exclusively for the purpose for which it has been designed.

Read these instructions carefully and retain for future reference.

- All units MUST be installed according to the procedures stated in the installation section of this manual
- In the case of new personnel, training is to be provided before operating the equipment
- DO NOT use this unit for any other purpose than its intended use
- DO NOT store explosive substances such as aerosol cans with a flammable propellant in or near this unit
- Keep fingers out of "pinch point" areas
- Unit is not waterproof DO NOT use jet sprays, hoses or pour water over/on the exterior of the unit
- Only use this unit with voltage specified on the rating label
- Do NOT remove any cover panels that may be on the unit
- DO NOT use sharp objects to activate controls
- If any fault is detected, refer to troubleshooting
- The manufacturer declines any liability for damages to persons and/or things due to an improper/wrong and/or unreasonable use of the machine

Service

- Only specifically trained/qualified Technicians (Stoddart, one of our service agents, or a similarly qualified persons) should carry out any and all repairs, maintenance and services

Setting Up

	WARNING
	Improper installation, adjustments, alterations, service or maintenance can cause property damage, injury or death.

Handling

- Use suitable means to move the unit: eg. A lift truck or fork pallet trucks (the forks should reach more completely beneath the unit)

Unpacking

- Check the unit for damage before and after unpacking. If unit is damaged, contact the distributor and manufacturer
- Should any item have physical damage, report the details to the freight company and to the agent responsible for the dispatch within seven (7) days of receipt. No claims will be accepted or processed after this period
- The unit is supplied fully assembled
- Remove all protective plastic film, tapes, ties and packers before installing and operating
- Clean off any remaining residue from the interior/exterior of the unit using a clean cloth dampened with warm soapy water

Positioning

- Choose an area that is well ventilated and provides access for future maintenance
- Place the unit on a level stable work surface capable of supporting its weight
- Do not position the unit in a wet area, an area with a lot of heat and steam or near flammable substances
- Allow an air gap between the unit and other objects or surfaces. We recommend a minimum gap of 100mm for normal operational use (if the unit is near any heat sensitive material we suggest you allow additional space)
- Please consult national and local standards to ensure that your unit is positioned in accordance with any existing requirement

Disposal

- At the end of the appliance's working life, make sure it is scrapped & components recycled properly
- Current environmental protection laws in the state/country of use must be observed
- Doors must be removed before disposal
- Power supply cable must be removed before disposal
- For further information on the recycling of this product, contact the local dealer/agent or the local body responsible for waste disposal

Electrical Connection

	WARNING
	<p>This unit must be installed in accordance with AS/NZS 60335.1</p>

Information

Aggregate electrical ratings of the Unit are expressed in kilowatts in this manual.

Single Phase Units:

Supplied with an appropriately rated plug and lead fitted and be indicated as:

- 10A plug & lead fitted
- 15A plug & lead fitted
- 20A plug & lead fitted

On-site Connection:

- The electrical supply must comply with the rating plate data
- Ensure that the unit is connected to a suitably rated and earthed power source
- Ensure that there is an isolation switch installed near the unit
- If the supply cord is damaged, it must be replaced by the manufacturer, its service agent or similarly qualified persons in order to avoid a hazard. Please contact Stoddart for parts and we will advise how to do this in order to avoid any electrical hazard
- The power cable should be dry and/or isolated from moisture or water

	WARNING
	<p>Some procedures in this manual require the power to the equipment to be turned off and isolated. Turn the power OFF at the power point and unplug the power supply lead by the plug body. If the power point is not readily accessible turn the equipment off at the isolation switch or the circuit breaker in the switchboard. Attach a yellow “CAUTION-DO NOT OPERATE” tag. This must be performed where relevant unless the procedures specify otherwise. FAILURE TO DO SO MAY RESULT IN ELECTRIC SHOCK.</p>

Technical Specifications

W.GPC62SC

Specifications	
Model	W.GPC62SC
Height	331mm
Width	468mm
Depth	578mm
Power	2.2kW
AMPS	10A plug & lead fitted

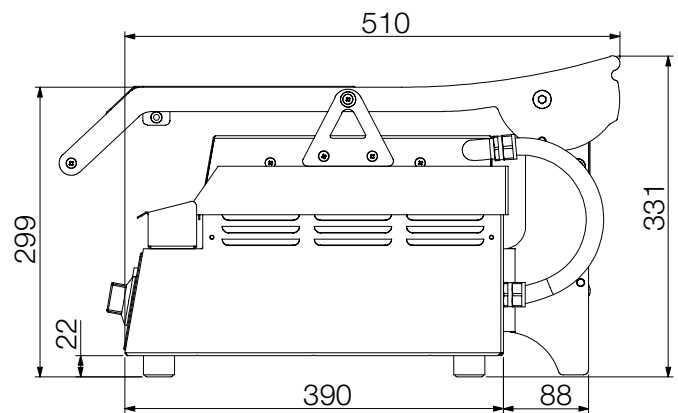
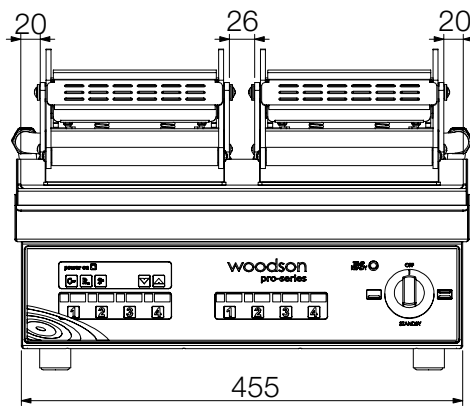
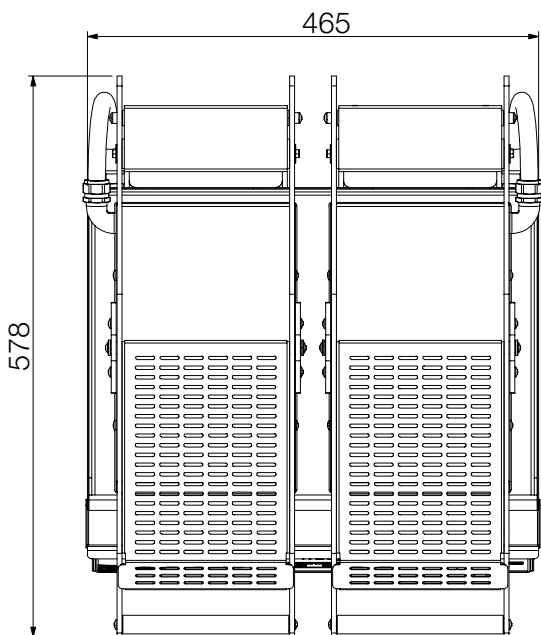

W.GPC61SC

Specifications	
Model	W.GPC61SC
Height	331mm
Width	360mm
Depth	578mm
Power	2.2kW
AMPS	10A plug & lead fitted

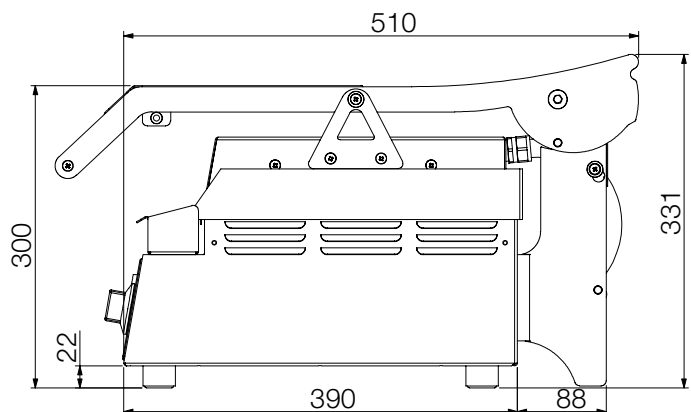
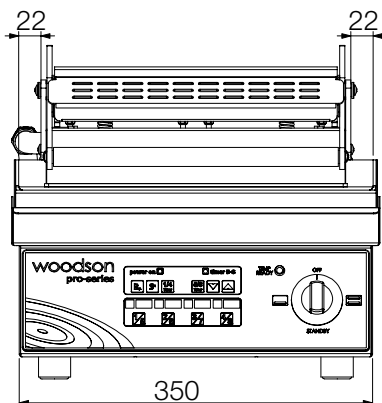
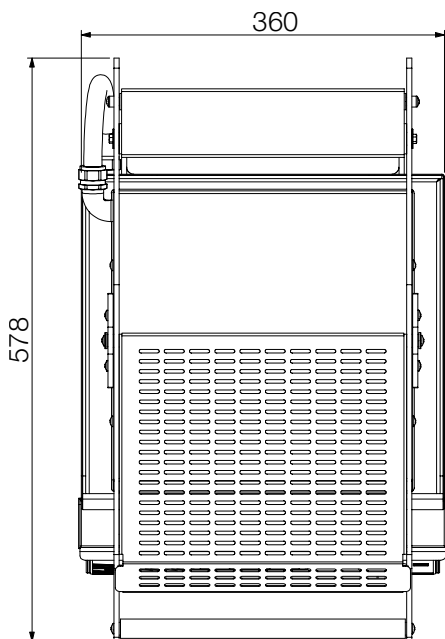

W.GPC350

Specifications	
Model	W.GPC350
Height	331mm
Width	410mm
Depth	630mm
Power	2.2kW
AMPS	10A plug & lead fitted

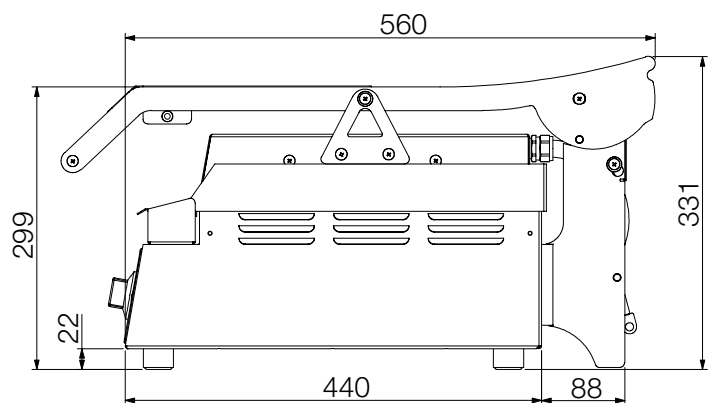
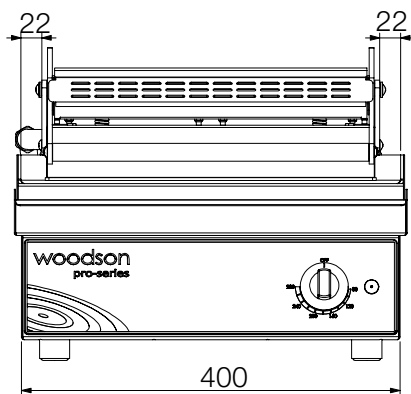
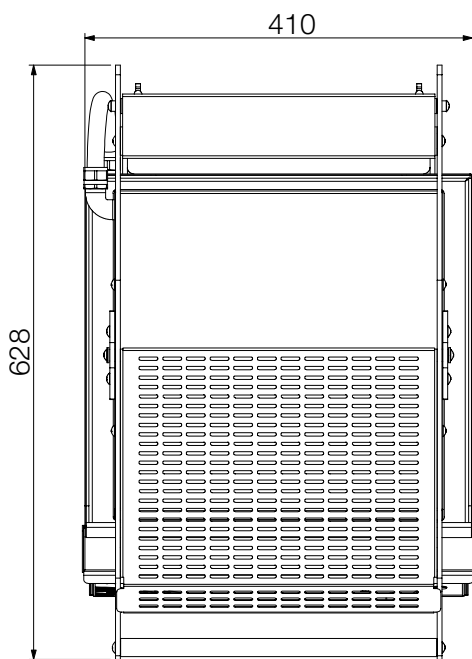

Operating Instructions

First Time Operation (W.GPC61SC, W.GPC62SC)

Upon setting up your equipment, the following steps must be followed to setup the timer and temperature:

When this unit is initially switched on, the display will show pre-set factory settings.

The Control panel has 8 timers located along the front of the control panel. The displays indicate the pre-programmed times in minutes and seconds.

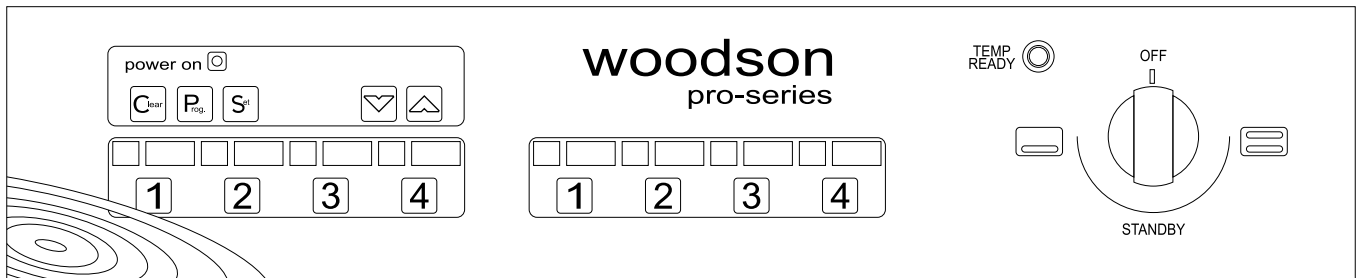

1. To change the **"TIME"** settings, Press and hold the **"Prog"** Programme Button for 3-4 seconds
2. Display 1 will flash
3. Press the **∇ ▲** buttons to adjust time if necessary
4. Press the **"Set"** Set button
5. Repeat the above steps for the other display timer buttons if necessary (i.e. 1, 2, 3, 4 - 1, 2, 3, 4)

Note: By pressing the programme button again, it will automatically go to the next timer display in order of sequence, i.e. 1,2,3,4 - 1, 2, 3, 4). The temperature can only be adjusted after the toaster has been turned on and allowed to operate through 2-3 cycles.

Operation (W.GPC61SC, W.GPC62SC)

1. Ensure that the top plate is in a closed position
2. Turn the power switch to the desired mode i.e. Top and bottom plate for normal press toasting, Bottom plate for Griddle style operation or Standby. The power **"ON"** indication light located on the L/H side control panel and Power ready light will be illuminated. If the indicator light does not illuminate refer to the trouble shooting section of the manual
3. Allow the press toaster to preheat for approximately 30 minutes. The **"Temp Ready"** indicator light will turn itself **"OFF"** once the press toaster has reached its optimum operating temperature. The press toaster is preset to operate between 205°C - 210°C surface cooking temperature

Note: Do not use the press toaster until the temperature ready light is off, as you will not achieve optimum product quality results.

4. Ensure that the 4 display timers are set to the desired cook time on the control panel (refer to programming the toaster instructions in this manual)
5. Lift the top plate up to a fully open position by the handle provided
6. The top plate will remain in the open position, as it is spring-loaded
7. Take extreme care when lifting, do not touch the cover or cooking surface to avoid skin burns
8. Place the food product onto the cooking surface and close the top plate
9. Ensure that the product is placed centrally of the cooking surface, to prevent the top plate from tilting and producing uneven product.
10. Press the appropriate display timer button (i.e. 1,2,3,4) to start the cooking procedure. The time shown in the window above the corresponding button will begin to count down
11. Once the count down timer reaches "000", the timer will emit a beeping sound. Press the appropriate display timer button again, to de-activate the timer. Lift the top plate fully to the open position and remove the toasted product
12. Close the top plate

Note: The timer can be stopped if necessary, by pressing the timer button and holding it for 3 seconds.

Note: To ensure optimum product quality, the top plate must be closed after every operation of unit, to maintain constant temperature.

Operation (W.GPC350)



1. Ensure that the top plate is in a closed position
2. Set the thermostat To 200°C. The indicator light will illuminate indicating that the grill is heating. If the indicator light does not illuminate refer to the trouble shooting section of the manual
3. Allow the press toaster to preheat for approximately 30 minutes. The indicator light will turn itself off once the press toaster has reached the set temperature.

Note: Do not use the press toaster until the temperature ready light is off, as you will not achieve optimum product quality results.

4. Lift the top plate up to a fully open position by the handle provided
5. The top plate will remain in the open position, as it is spring-loaded
6. Take extreme care when lifting, do not touch the cover or cooking surface to avoid skin burns
7. Place the food product onto the cooking surface and close the top plate
8. Ensure that the product is placed centrally of the cooking surface, to prevent the top plate from tilting and producing uneven product.
9. Cook product until desired results are achieved. Lift the top plate fully to the open position and remove the toasted product
10. Close the top plate

Note: During intermittent use, it is recommended that the plates be kept closed when not cooking. While closed, the temperature should be turned down to around 150oC. This will minimise heat loss, save power and provide a faster heat up time when the grill is next required.

Cleaning

General Information



- Cleaning is recommended for health and safety purposes and to prolong the life of the unit
- Do NOT use abrasive pads or cleaners on the stainless steel or any other metal parts of the unit
- Do NOT use industrial chemical cleaners, caustic based cleaners or bleaches and bleaching agents, many will damage the metals and plastics used on this unit
- When drying, metal surfaces should be wiped with a soft cloth in the same direction as grained polish
- Do NOT remove any screws for cleaning. All internal sections of the unit are to be cleaned by a qualified technician
- This unit is NOT waterproof, do NOT hose, do NOT pour water directly onto the unit, do NOT immerse in water

Corrosion Protection

- Stainless steel exhibits good resistance to corrosion however, if not properly maintained stainless steel can rust and/or corrode
- Any sign of mild rust and/or corrosion should be thoroughly cleaned with warm soapy water and dried as soon as possible
- NEVER use abrasive pads or cleaners for cleaning
- All metal surfaces should be checked while cleaning for damage, scuffs or scrapes as these can lead to rust and further damage to the product
- Mild rust and/or corrosion can be treated with a commercial cleaning agent that contains citric/oxalic/nitric/phosphoric. Do NOT use cleaning agents with chlorides or other harsh chemicals as this can cause corrosion. After treatment, wash with warm (not hot) soapy water and dry thoroughly
- Thoroughly wipe the surfaces dry after cleaning and do NOT let water pool on the unit. Check crevices and folds for pooling
- When using, ensure all liquids and moisture is cleaned up straight away. Food liquids such as juices from vegetables and fruits should NOT be left on preparation surfaces
- Do NOT leave items on the stainless steel such as cutting boards, rubber mats and bottles

Surface Finish

- To protect the polish, stainless steel should be dried by wiping a dry soft cloth in the same direction as grained polish
- For NON-food contact surfaces, a light oil can be wiped on the surfaces with a cloth to enhance the stainless steel surface. Wipe in the direction of the grain
- Some commercial stainless stain cleaners can leave residue or film on the metal; this may trap fine particles of food on the surface, thus deeming the surfaces not food safe

	<p style="text-align: center;">WARNING</p> <p style="text-align: center;">This unit is NOT waterproof, do NOT hose. DO NOT pour water directly onto the unit. DO NOT immerse in water</p>
	<p style="text-align: center;">IMPORTANT</p> <p style="text-align: center;">Some commercial stainless stain cleaners leave residue or film on the metal that may entrap fine particles of food, thus deeming the surface not FOOD SAFE.</p>
	<p style="text-align: center;">WARNING</p> <p style="text-align: center;">Wait until the unit has cooled to a safe temperature before undertaking any cleaning or maintenance. Contact with hot surfaces can cause burns and serious injury.</p>

Cleaning Schedule

- Daily cleaning is required for Contact Grills, and external surfaces. This will help to maintain and prolong the efficiency of your unit
- The grill plate should be kept clean at all times, free from carbon and burnt materials
- The unit should be cleaned at the end of each work day

Materials Required

- Stainless Cleaner
- Non Abrasive Cleaning pad
- Clean Sanitised Cloth
- Paper Towel
- Container of warm water
- Nylon Brush
- Appropriate PPE (Personal Protective Equipment)

Cleaning Procedure

1. Isolate the unit from the power supply
2. Using a good quality nylon brush remove crumbs and small food items
3. Clean the grill plate with a spatula or grill stone to the original appearance for faster cooking
4. Wipe clean using a cloth dampened (not wet) with clean warm water until all soil has been removed

Cleaning Procedure - External Surfaces

1. Isolate the unit from the power supply
2. Wearing Personal Protective Equipment (PPE), apply Stainless Cleaner with the Cleaner pad to the external surfaces
3. Scrub any baked on soil with the cleaner pad in the same direction as grained polish
4. Wipe clean using a cloth dampened with clean warm water until all Stainless Cleaner and soil has been removed
5. Using a clean sanitised cloth, thoroughly wipe the stainless steel and metal parts dry. Do NOT let water pool on the unit. Check crevices and folds

Note: In some areas, particularly seaside environments, stainless steel can be subject to surface discolouration or “tea staining” This can be removed with an appropriate cleaning agent which contains 10% sodium citrate. Ask your supplier of cleaning chemicals for a suitable brand.

Troubleshooting

	WARNING
	Technician tasks are only to be completed by qualified service people. Check faults before calling service technician.

Task Type - (O) = Operator
(T) = Technician Task

Problem	Possible Causes	Task	Possible Corrective Action
Unit not heating	Unit not turned "on" at the power supply	O	Turn power to "on" at the power supply
	"On/Off" not turned on	O	Switch on power on the control panel
	Thermal Safety fuse blown	T	Call service technician
Plates too Cold	Allow ready light to turn off before cooking	O	
	Temperature requires adjusting	T	Refer to temperature adjustment in the manual
	Element failure		Test & replace the element if necessary
Plates too Hot	Temperature requires adjusting	T	Refer to temperature adjustment in the manual
	Relay or thermostat failure	T	Test & replace the relay and/or thermostat if necessary
Food sticks to surface of plates	Plates too hot	O	Adjust temperature
	No Grease/Oil to lubricate surface of plates	O	Apply film of oil to plates
	Plates not clean	O	Clean Plates