

# Single Plate Contact Toaster

**The Pro-Series contact toasters are equipped with a host of features that improve performance, functionality and ease of cleaning.**

**Used in quick service restaurants around the globe, these are the true professionals' choice.**

## FEATURES & BENEFITS

- Single piece stainless steel plate and protective upstand
- Single top plate (300 x 300mm) and one large bottom plate (345 x 310mm)
- Excellent heat distribution across entire cooking surface
- Smooth internal corners for easy cleaning
- Large removable grease tray
- Easily removable protective heat shields for increased operational safety – dishwasher safe
- 3 mode operation – Both plates, bottom plate only and standby - For increased energy efficiency (Reduces energy costs during non-busy periods)
- Eight programmable timer settings with one touch operation to achieve consistent results
- The top-plate is assisted by gas struts to enable effortless and safe lifting operation and ensures gentle pressure for optimal toasting
- Design of lifting mechanism ensures the plate will not fall down and cause burns to operators
- Drip-proof ventilation grills on rear and side of unit
- Dual-adjustable thermostats at rear of unit control temperatures for operation modes
- LED timer display



Rigid, heat protective handle



New energy saving plate selection control



Protective heat shield



## W.GPC61SC



## SPECIFICATIONS

**kW 2.2    Amps 10**  
**Width 360    Depth 578**  
**Height (open) 765    Height (Closed) 331**  
**Weight 25kg**

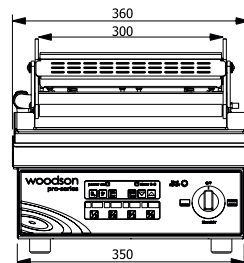

Front View

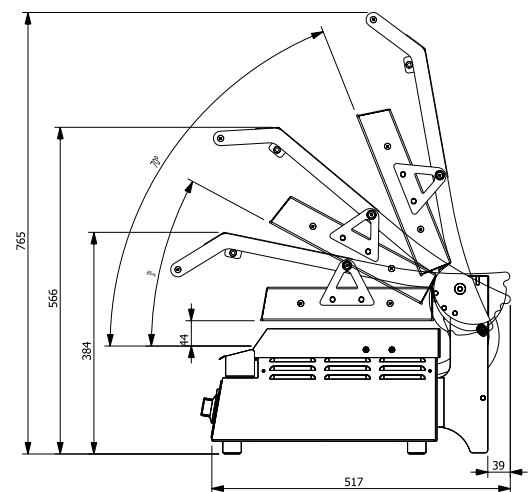

Side View

**We reserve the right to alter specifications of products without notice. All dimensions are in mm.**

Dealer: