

P18 Counter Top Pizza Conveyor Oven



Left and right feed available

The P18 is Starline's smallest pizza conveyor. It provides a robust, user friendly and efficient way of cooking up to approx 38 x 9" pizzas per hour.

Alongside it's easy "set and forget" operation, the P18 unit incorporates metal incaloy elements and fan forced technology enabling efficient power use and product output.



Touch pad "set and forget" control panel

FEATURES & BENEFITS

- Robust, compact countertop pizza conveyor oven
- Long life metal elements for continuous use
- Longer and wider cooking conveyor for easy loading and higher production
- Touchpad "set and forget" control system
- Fan cooled controls and fan forced heat technology
- Energy efficient pulse power independent temperature controls for top and bottom elements
- Variable speed belt control with automatic tensioning
- Stainless steel construction
- Has a belt width of 457mm and a chamber dimension of 480mm wide, 750mm long, with a 55mm clearance
- Supplied with 2 metre lead for 3PH hard wiring on site by a qualified electrician
- Units configured for right to left conveyor operation as standard. Left to right operation can be selected at time of order by adding an "L" to end of the model number.

W.CVP.C.18

Approx. Pizza Capacity (per hour)

W.CVP.C.18	38 x 9" pizzas* 18 x 12" pizzas*
------------	-------------------------------------

SPECIFICATIONS

kW 10.8 **Power** 3Ø + N + E
Length 610mm **Width** 1500mm
Height 440mm
Oven Chamber Width 480mm
Oven Chamber Length 750mm
Oven Head Clearance 55mm

Dealer:

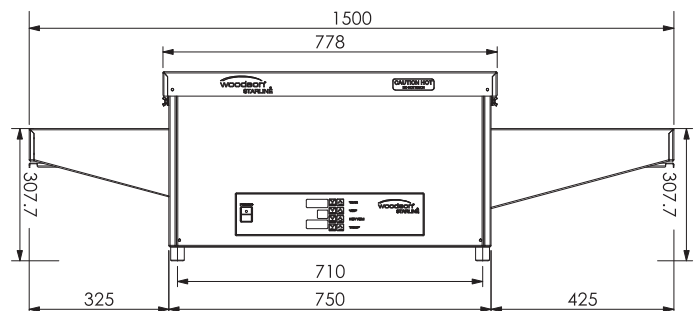
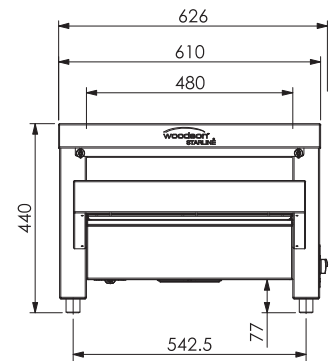

We reserve the right to alter specifications of products without notice. All dimensions are in mm.