



HOSHIZAKI ICE MACHINES

IM-240ANE Series Ice Machine

Product Features

- Up to 240kg of ice per day
- Rated to 40°C ambient temperature (Tropical Conditions)
- New intelligent control circuit dedicated to saving power and water consumption
- Micro computer controller controls ice making process to work at peak performance in any conditions
- Inbuilt safety features – freeze cycle back up timer, defrost back up, low voltage & high amp protector
- New 7 segment operational display panel for ease of use
- Unique closed cell water circuit for ultimate contamination protection
- Durable Stainless Steel Exterior
- Easily accessible & cleanable air filters reduce costly callouts
- Exceptionally hard crystal clear cubes that melt slowly
- Auto rinse and flush cycle
- 2 year parts & labour warranty on entire unit, 2 year (parts only) on compressor & air cooled condenser coil

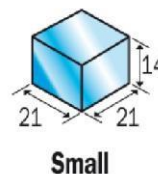

Small

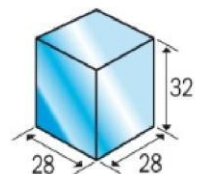

Large

Simply the world's best ice™



IM-240ANE Series Ice Machine



HOSHIZAKI
ICE MACHINES

Product Specifications

Model	Cooling	Weight	AC Supply Voltage	Refrigerant	Ambient	Water Temp	Water Pressure
IM-240ANE	Air	Net: 80kg	220-240V/ 50Hz	R404a	1 – 40°C	5 – 35°C	50 – 800kPa
IM-240AWNE	Water	Packed: 91kg	10Amps				

Ask Hoshizaki representative for additional information if required

Ice Production Specifications

Model	Ice Production per 24 hours (Air / Water)			Ice Production per cycle	Freeze Cycle	Max Storage
	10°C/10°C	21°C/15°C	32°C/21°C			
IM-240ANE	220kg	205kg	160kg	3.2kg/140pcs	20mins	Select Bin
IM-240AWNE	230kg	215kg	205kg	3.2kg/140pcs	20mins	Select Bin

Please Note: above are approximate

IM-240ANE-21/28

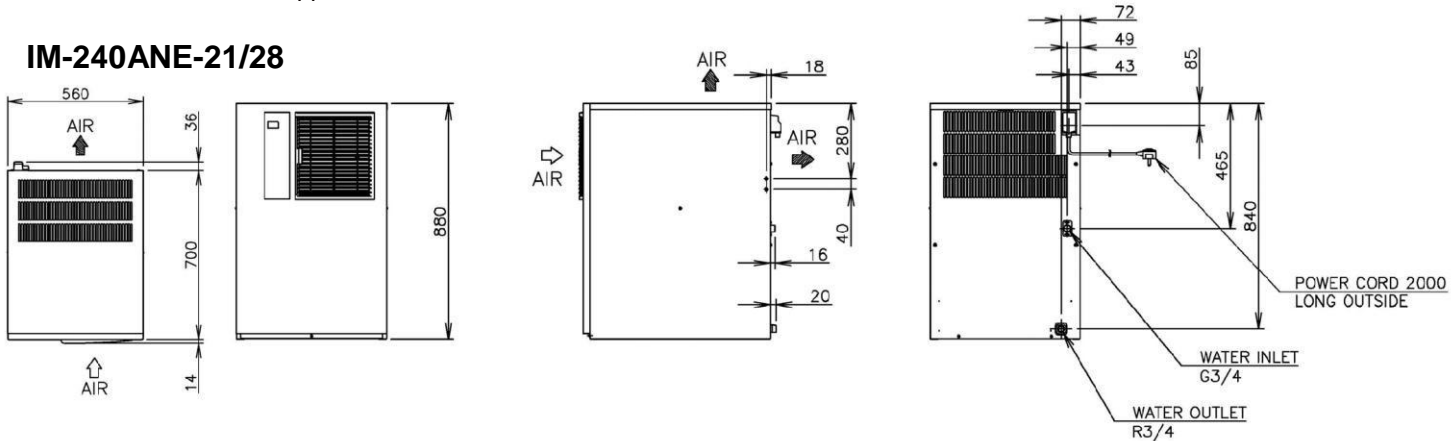

IM-240AWE-28

