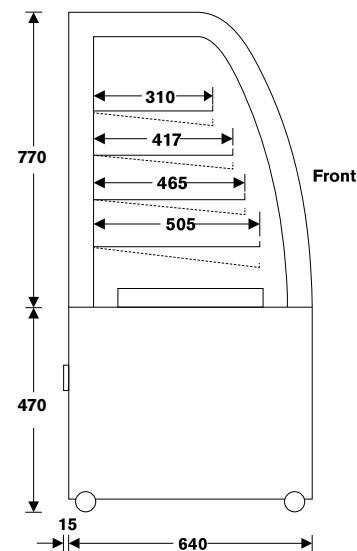

LH9

**STANDARD FEATURES**

- › **FrameFree** canopy that maximises fully the visibility of displayed food
- › Four shelf levels
- › Chrome wire shelving system that is height adjustable in 25mm increments and interchangeable between horizontal and tilted positions
- › High quality European heating and control components
- › Thermostatically controlled to operate at a temperature between 30 – 95°C
- › Fan forced air flow for even heat distribution
- › Rapid response element for better temperature control
- › **SlimLED** under-shelf LED strip lighting with 12V safety
- › Rear sliding doors on friction-free, low wear tracks (doors removable for cleaning)
- › Mounted on swivel and lockable castors allowing easy movement of cabinet

**For Factory Options refer to page 60****For Cabinet Accessories refer to page 72****SIDE VIEW**

# LINCOLN: HEATED

This designer cabinet allows great viewing of heated food offerings, simply drawing the customer in to encourage food purchase.

**up to 95°C operating temperature**

Model	LH6	LH9	LH12	LH15
Length	600mm	900mm	1200mm	1530mm
Depth*	640mm	640mm	640mm	640mm
Height	1240mm	1240mm	1240mm	1240mm
Available Display Area	0.85m <sup>2</sup>	1.4m <sup>2</sup>	1.9m <sup>2</sup>	2.4m <sup>2</sup>
Power Connection	10A Plug	10A Plug	10A Plug	20A Plug

\*Add extra 15mm for protruding control panel and switches