



CB14

**STANDARD FEATURES**

- › **FrameFree** canopy that maximises fully the visibility of displayed food from all sides
- › Open at rear (no doors)
- › Internal chrome wire shelf for holding plates
- › **DoubleJacket** long life halogen heat lamps mounted under shelf
- › Gastronorm pans not supplied with unit
- › Fixed front glass
- › Thermostatically controlled to operate at a temperature up to 95°C
- › Drain with faucet built in
- › Can be operated wet or dry

**SIDE VIEW**

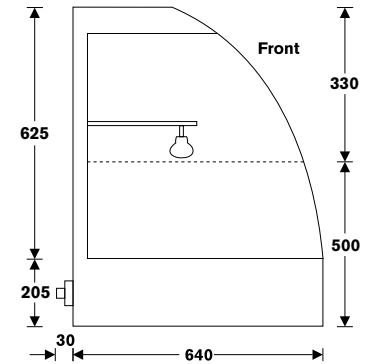

**For Factory Options refer to page 60**

**For Cabinet Accessories refer to page 72**

# CORNWALL: BAIN MARIE

An elegant looking Bain Marie cabinet for getting the most out of hot food offerings.

**up to 95°C operating temperature**

Model	CB7	CB11	CB14	CB17	CB20
Length	745mm	1070mm	1395mm	1720mm	2045mm
Depth*	640mm	640mm	640mm	640mm	640mm
Height	830mm	830mm	830mm	830mm	830mm
No. of Gastro 1/1 Pans**	2	3	4	5	6
Power Connection	10A Plug	15A Plug	20A Plug	Fixed Wiring	Fixed Wiring

\*Add extra 30mm for protruding control panel, switches and cable exit

\*\*Up to 100mm deep. (Gastronorm pans not supplied)