

MX20ATS Reach-in Blast Chiller / Freezer

Standard Features

- Free standing unit on legs
- Ergonomic touch screen controls integrated into the door
- 5 function home screen
- Manual use – Soft Chill, Hard Chill, Soft Freeze, Hard Freeze and Self Adaptive I-Chilling
- 99 program cycles
- Favourites key – shortcuts to the last 9 programs used
- Pre-chilling cycle key to maximise efficiency
- Multi-point core temperature probe
- Timer mode or continuous run
- Integrated door latch to keep door open when not in use
- Automatic fan stop when opening the door
- Operator selectable de-icing cycle
- External and internal finish made of 304 stainless steel
- Front frame with anti-condensation system
- Injected polyurethane foam insulation - 60mm thick



Please refer to Moffat price list for options and accessories

Dimensions

Technical data

Tray capacity	4 x 1/1GN trays
Tray clearance	74mm
External dimensions	W 770mm x D 790mm x H 945mm
Load capacity	20kg*
Electrical connections	1P+N+E, 230-240V, 50/60Hz, 10A, 1.6kW
Nett weight	115kg
Air-cooled condensing unit - Refrigerant type	R404A
Ambient temperature requirement	+15°C — +32°C

* Note – Load capacities may vary depending on the thermal conductivity of the food being chilled, the thickness of product and container used

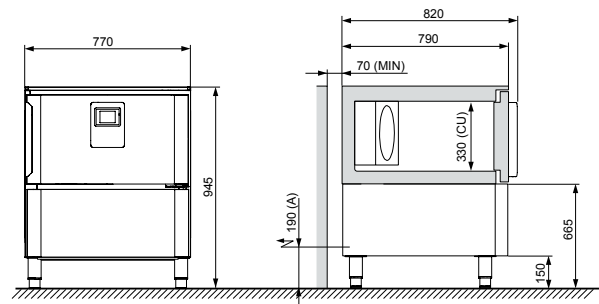

(M1) MX20ATS
(A) Electrical supply
(CU) Useful
(MIN) Minimum

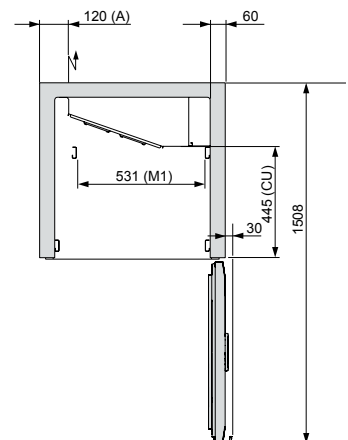

Australia
moffat.com.au

Moffat Pty Limited
740 Springvale Road
Mulgrave
Victoria 3170
Australia
Telephone +613-9518 3888
Facsimile +613-9518 3833
vsales@moffat.com.au

New Zealand
moffat.co.nz

Moffat Limited
45 Illinois Drive
Izone Business Hub
Rolleston 7675
New Zealand
Telephone +64 3-983 6600
Facsimile +64 3-983 6660
sales@moffat.co.nz

Disclaimer: All unit capacities are based on subjective testing. Moffat accepts no liability for production values. In line with policy to continually develop and improve its products, Moffat Limited reserves the right to change specifications and design without notice.