

CW3H

1800mm 3 Hole Gas Waterless Woks

CW3H-CCC 3 Hole, 3 Chimney Burners

CW3H-CCD 3 Hole, 2 Chimney Burners, 1 Duckbill Burner

CW3H-CDD 3 Hole, 1 Chimney Burner, 2 Duckbill Burners

CW3H-DDD 3 Hole, 3 Duckbill Burners



CW3H

- 800mm compact depth
- Cobra suite matching
- Waterless wok deck
- 14" wok hole
- Duckbill and Chimney burner model options
- 105 MJ/hr 18 jet Duckbill burners¹
- 95 MJ/hr 24 jet Chimney burners
- High splashback with shelf
- Water folding laundry arm on splashback
- Rear waste channel
- Stainless steel spill tray
- Lift out wok ring
- Flame failure protection with pilot burner

Also Available



CW1H



CW2H



Duckbill burner



Chimney burner

OVERALL CONSTRUCTION

- Full chassis construction
- Double skin insulated wok deck
- Stainless steel exterior finish
- Heavy-duty cast iron wok rings (removable)
- Stainless steel spill tray
- 63mm dia. stainless steel legs with adjustable feet

CONTROLS

- Pilot On/Off control with flame failure valve
- Main burner On/Off valve with High-Low burner adjustment
- Quarter turn main burner control handles
- Quarter turn water valve handle

CLEANING AND SERVICING

- Stainless steel exterior finish
- Lift out wok rings for full cleaning ability
- Slide out spill tray
- Rear waste channel with removable grate for debris collection
- Access to all parts from front and top for servicing

¹ NZ models Duckbill burner rating 105MJ/hr Natural Gas / 85MJ/hr on LP gas.

Matching Products



CSP6

CN4

CT9

CP4

CS9 / C900-S

C6B

CR9D

CR6C

CF4

C9C

CW3H

1800mm 3 Hole Gas Waterless Woks

CW3H-CCC 3 Hole, 3 Chimney Burners

CW3H-CCD 3 Hole, 2 Chimney Burners, 1 Duckbill Burner

CW3H-CDD 3 Hole, 1 Chimney Burner, 2 Duckbill Burners

CW3H-DDD 3 Hole, 3 Duckbill Burners

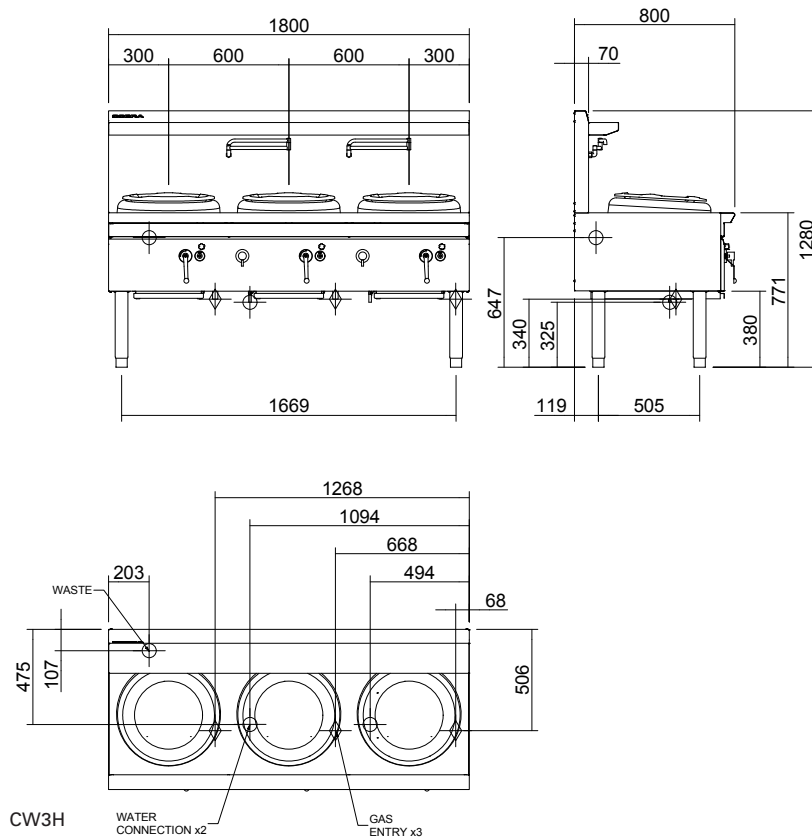

CW3H

SPECIFICATIONS

Burners

95MJ/hr 24 jet Chimney burner
105MJ/hr 18 jet Duckbill burner
(NZ - LP gas rating 85 MJ/hr)

Gas Rating - Total

CW3H-CCC 285 MJ/hr
CW3H-CCD 295 MJ/hr
(NZ- LP gas rating 275 MJ/hr)
CW3H-CDD 305 MJ/hr
(NZ- LP gas rating 265 MJ/hr)
CW3H-DDD 315 MJ/hr
(NZ- LP gas rating 255 MJ/hr)

Wok size

14" wok ring
Suits woks 40-60cm / 16-24"

Gas connection (x3)

Separate gas connection for each wok hole. R3/4 (BSP) male each wok hole 506mm from rear, 340mm from floor, 68mm, 668mm and 1268mm from RH side

All units supplied with Natural-LP gas regulators for each wok connection
Supplied gas regulators include Test Point for appliance operating pressure
Supplied regulator(s) must be fitted to each appliance gas connection when installed
Water connection (x2)
Cold water connection
2 x 1/2" O.D. copper tube
475mm from rear, 325mm from floor, 494mm and 1094mm from RH side
Drain connection
Connection to waste drain 1-1/4" BSP drain waste
107mm from rear, 647mm from floor, 203mm from LH side

Dimensions
Width 1800mm
Depth 800mm
Height 771mm
Incl. splashback 1280mm
Nett weight 194kg
Packing data 2.19m³, 294kg
Width 1835mm
Depth 865mm
Height 1382mm
Gas types
Available in Natural gas and LP gas, please specify when ordering

moффat.com.au
moффat.co.nz

Australia
moффat.com.au

Moffat Pty Limited

Victoria/Tasmania
740 Springvale Road
Mulgrave, Victoria 3170
Telephone +613-9518 3888
Facsimile +613-9518 3833
vsales@moffat.com.au

New South Wales
Telephone +612-8833 4111
nswsales@moffat.com.au

South Australia
Telephone +613-9518 3888
vsales@moffat.com.au

Queensland
Telephone +617-3630 8600
qldsales@moffat.com.au

Western Australia
Telephone +618-9413 2400
wasales@moffat.com.au

New Zealand
moффat.co.nz

Moffat Limited

Rolleston
45 Illinois Drive
Izone Business Hub
Rolleston 7675
Telephone +64 3-983 6600
Facsimile +64 3-983 6660
sales@moffat.co.nz

Auckland
Telephone +64 9-574 3150
sales@moffat.co.nz



Cert. No. AGA 6878G

In line with policy to continually develop and improve its products, Moffat Limited reserves the right to change specifications and design without notice.

© Copyright Moffat Ltd
AN.C.01.19 / 1598

an Ali Group Company



The Spirit of Excellence